

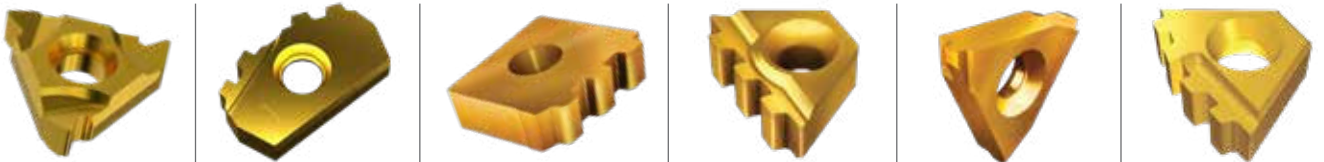

Oil&Gas

Professional Threading Solutions



METRIC

Professional Threading Solutions

Expanded Line of Thread Turning Solutions for the Oil and Gas Industry

Solutions for Pipes and Couplings

Vardex's advanced threading solutions for the oil and gas industry, now includes specialized solutions for tough and challenging applications in the following insert profiles:

- APIRD
- Buttress
- Extreme Line
- VAM
- New VAM
- Hughes H-90



Solutions for Rotary Drill Stem Connections

Unique insert design with strengthened cutting edge and increased tool life for the following Rotary Drill stem connections:

- **NC** - Number Connection
- **REG** -Regular Style
- **FH** - Full Hole
- **IF** - Internal Flash



Professional Threading Solutions

Specialized Thread Milling Solutions for the Oil & Gas Industry

Ask us about our specialized solutions for frac pump and valves manufacturers.

Contact your local Vargus distributor for ordering information.

Frac Pumps

Application

Common threads:

5.5"-6" -4 ABUT, 3/4"-10UNC



Recommended Solutions



Shell Mill (5/8" V Style)



V Style



Deep Threading - Full & Partial Profile

Valves

Application

Common threads:

UN, UNC, ACME, STACME, NPT, BSP



Ball



Gas Pipe



Butterfly

Recommended Solutions



MiTM 40 Standard



MiTM 40 Shell Mill



TM Solid - Helical Flutes with Thru-Hole Coolant



TMSD Vertical



TMSD U Style



TMSD L Style (3/8" L)

Professional Threading Solutions

Solutions for Machining Seal Components in Premium Connections

Vargus' new high precision inserts for the Oil & Gas industry are specially designed to reproduce a variety of different insert profile geometries accurately and consistently onto the component for optimized manufacturing of seal components.

Quotations for tailor-made solutions are available upon receipt of the seal component geometry.

Advantages:

- High indexability of insert cutting edges: $\pm 0.02 \text{ mm}$ ($\pm .0008''$)
- Profile geometry can be tailored to specific applications
- Economical inserts with 3 cutting corners
- Insert profile is copied onto the component for significantly reduced machining cycle times
- Shorter set-up time
- Simple CNC programming

Seal Component Machining

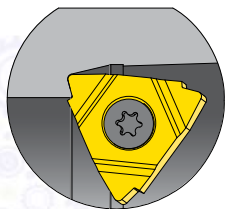
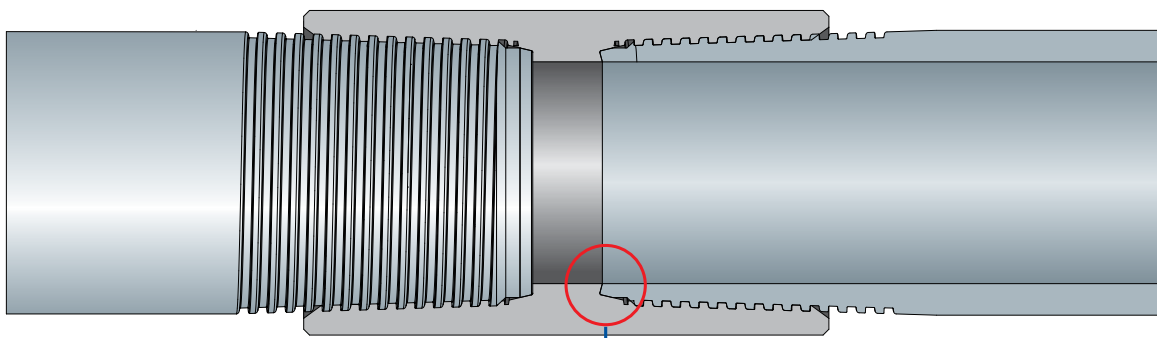

Profile Copied to the Coupling

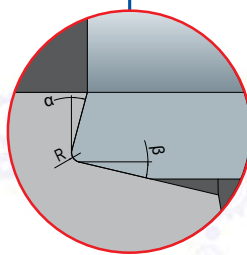

Sample Seal Component Geometry

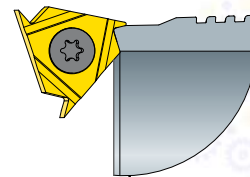

Profile Copied to the Pipe

INDEX

INSERTS

NPT
NPTF
American ACME
Stub ACME
API
API Buttress Casing
API Round Casing & Tubing
VAM
New VAM
EL-Extreme Line
Hughes H-90
GOST (OTTM/OTTG)

INTERNAL TOOLHOLDERS

8	MACH TT	57
12	Standard	60
14	Oil & Gas	62
18	Z+ Style	62
22	F-Line Standard	63
25	F-Line Multi+ Style	63
31	M+ Style	64
38	MACH 25	64
40	14D Standard	65
42	T+ Style	66
44	U Style	67
45	V Style	68

EXTERNAL TOOLHOLDERS

MACH TT
Standard
API with Coolant
Oil & Gas
Z Style
F-Line Standard
F-Line Multi+ Style
MACH 25
14D Standard
T+ Style
U Style
Slim Throat
V Style

SPECIAL SOLUTIONS

46	Special Toolholder Solutions	69
----	------------------------------	----

TECHNICAL DATA

48		
49		
50		
51		
51	Calculating the Helix Angle and Choosing the Right Anvil	70
52	Anvils	72
52	Technical Data	72
53	Recommended Grades and Cutting Speeds	74
54		
55		
56		
56		



Supersonic Thread Turning



Specialized Oil & Gas Threading Solutions



FEATURES AND INNOVATIONS

- Improved Rake & Reinforced Geometry**
 For high resistance with a reduced number of passes
- VK8 Grade**
 High wear resistance for general purpose applications AlTiN + TiN PVD coating
- Improved Profile Design**
 Superior threading surface finish
- Advanced Surface Treatment**
 Reinforced cutting edge and smooth surface finish



Decreased Number of Passes



Reduced Machining Time



Longer Tool Life

VERSATILE SYSTEM

One holder can use either single-sided or double-sided inserts



25D
(double-sided)



25S
(single-sided)



UNMATCHED PRODUCTIVITY

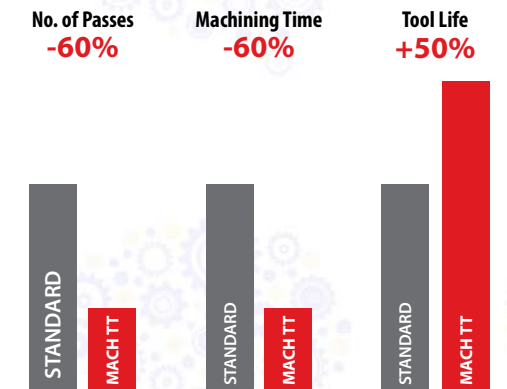

Now available in:

- External - IC 3/8" & IC 1/2"
- Internal - IC 3/8"

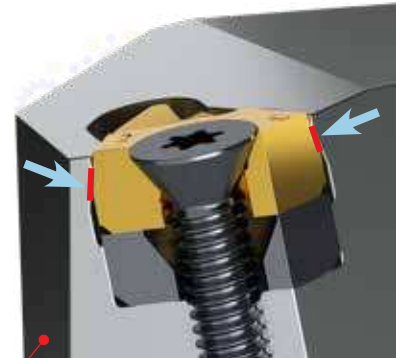

MACH TT Dovetail Clamping System

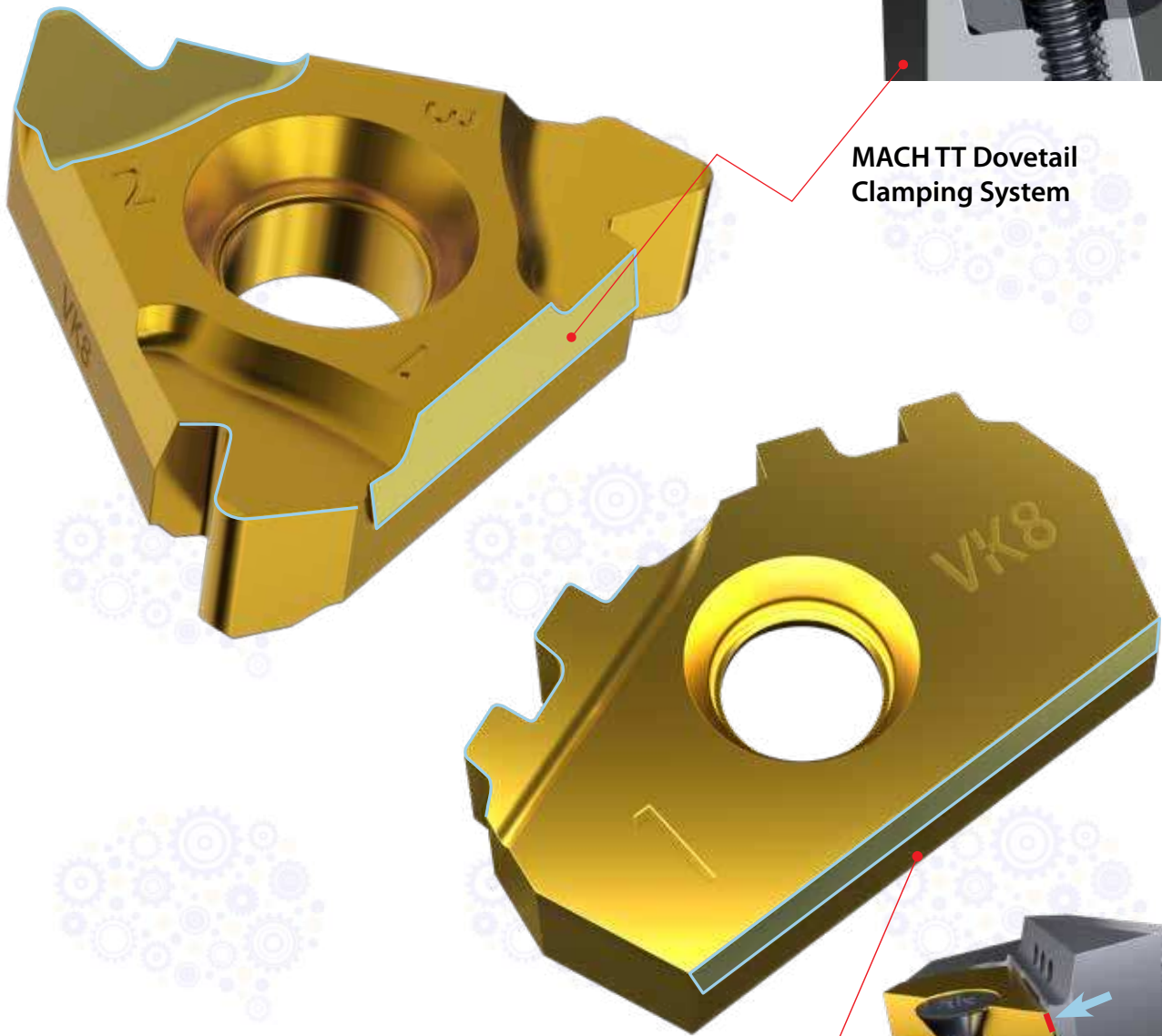

MACH 25 Dovetail Clamping System

Super rigid - designed for high loads

ТОВ «СМАРТТЕК ІНЖИНІРИНГ», Т. +380-50-396-90-96, info@smarttec.com.ua, https://www.smarttec.com.ua

NPT

External

Defined by: USAS B2.1:1968
Tolerance class: Standard NPT

MACH TT

Standard

SCB Sintered Chipbreaker

Slim Throat



Insert Size	Pitch		Ordering Code	Dimensions mm			Anvil	
	IC	L mm		TPI	RH	h min	X	Y
3/8"	16	27	3DTER27NPT...	0.66	1.6	0.8	YE3	AL..-3DT
		18	3DTER18NPT...	1.01	1.5	0.9		
		14	3DTER14NPT...	1.33	1.5	1.4		
		11.5	3DTER11.5NPT...	1.64	1.5	1.4		
		8	3DTER8NPT...	2.42	1.2	1.8		

* For related holders see pages 46-47.

Standard

SCB

Insert Size	Pitch		Ordering Code	Dimensions mm			Anvil		
	IC	L mm		TPI	RH	h min	X	Y	RH
1/4"	11	27	2ER27NPT...	0.66	0.7	0.8		-	NL..-2
		18	2ER18NPT...	1.01	0.8	1.0			
		14	2ER14NPT...	1.33	0.8	1.0			
3/8"	16	27	3ER27NPT...	0.66	0.7	0.8	YE3	AL..-3	
		18	3ER18NPT...	1.01	0.8	1.0			
		14	3ER14NPT...	1.33	0.9	1.2			
		11.5	3ER11.5NPT...	1.64	1.1	1.5			
3/8" SCB	16	27	3JER27NPT...	0.66	0.6	0.8	YE3	AL..-3	
		18	3JER18NPT...	1.01	0.6	0.8			
		14	3JER14NPT...	1.33	1.1	1.5			
		11.5	3JER11.5NPT...	1.64	1.1	1.5			
8	3JER8NPT...	2.42	1.0	1.5					

* For related holders see pages 48-49.

Slim Throat

Insert Size	Pitch		Ordering Code	Dimensions mm				Toolholder*
	IC	L mm		TPI	RH	h min	X	
1/4"V	11	27	2VER27NPT...	0.66	0.7	2.0	3.2	NL..-2V
		18	2VER18NPT...	1.01	0.7	1.8	3.2	
		14	2VER14NPT...	1.33	0.7	1.8	3.2	
		11.5	2VER11.5NPT...	1.64	0.7	2.1	3.2	
3/8"V	16	27	3VER27NPT...	0.66	1.1	2.9	3.6	NL..-3V
		18	3VER18NPT...	1.01	1.1	2.6	3.6	
		11.5	3VER11.5NPT...	1.64	1.1	2.1	3.6	

* For related holders see page 56.



NPT (con't)

External

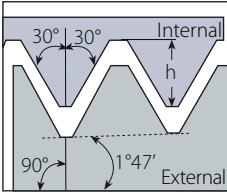
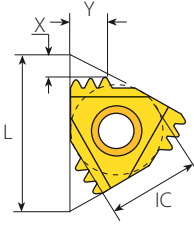
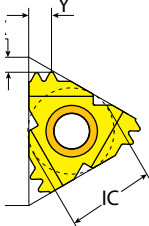
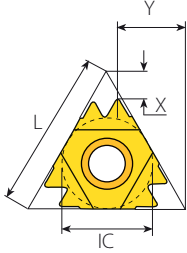
Defined by: USAS B2.1:1968
Tolerance class: Standard NPT

M+ Style F-Line Z+ Style

M+ Style



Insert Size		Pitch	Teeth	Ordering Code	Dimensions mm			Anvil	
IC	L mm	TPI		RH	h min	X	Y	RH	Toolholder*
3/8"	16	14	2	3ER14NPT2M+...	1.33	2.0	3.0	YE3M	AL..-3
1/2"	22	11.5	2	4ER11.5NPT2M+...	1.64	2.2	3.4	YE4M	AL..-4
5/8"	27	11.5	3	5ER11.5NPT3M+...	1.64	3.5	5.6	YE5M	AL..-5M
		8	2	5ER8NPT2M+...	2.42	3.1	4.9		

* For related holders see pages 48-49.

Z+ Style



Insert Size		Pitch	Teeth	Ordering Code	Dimensions mm			Anvil	
IC	L mm	TPI		RH	h min	X	Y	RH	Toolholder*
1/2"	22	11.5	2	4ER11.5NPT2Z+...	1.64	2.7	10.0	YE4Z	AL..-4Z
		8	2	4ER8NPT2Z+...	2.42	3.4	9.6		

* For related holders see pages 50-51.

F-Line M+ Style



Insert Size		Pitch	Teeth	Ordering Code	Dimensions mm			Anvil	
IC	L mm	TPI		RH	h min	X	Y	RH	Toolholder*
1/2"F	23	11.5	2	4FER11.5NPT2M+...	1.64	2.2	3.4	YE4M2F	AL...-4MF

* For related holders see page 52.

NPT (con't)

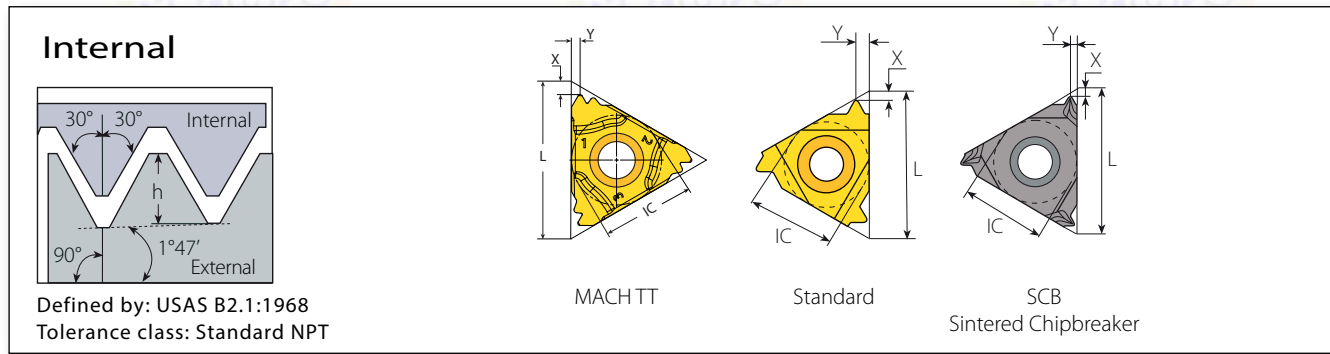

Insert Size		Pitch	Ordering Code	Dimensions mm			Anvil	
IC	L mm	TPI	RH	h min	X	Y	RH	Toolholder*
3/8"	16	27	3DTIR27NPT...	0.66	1.3	0.6	Y13	VRC..-3DT
		18	3DTIR18NPT...	1.01	1.1	1.0		
		14	3DTIR14NPT...	1.33	1.2	1.2		
		11.5	3DTIR11.5NPT...	1.64	1.2	1.3		
		8	3DTIR8NPT...	2.42	1.2	1.7		

* For related holders see pages 57-59.

Standard



SCB

Insert Size		Pitch	Ordering Code	Dimensions mm			Anvil	
IC	L mm	TPI	RH	h min	X	Y	RH	Toolholder*
1/4"	11	27	2IR27NPT...	0.66	0.7	0.8	-	NVR..-2
		18	2IR18NPT...	1.01	0.8	1.0		
		14	2IR14NPT...	1.33	0.8	1.0		
1/4" SCB	11	27	2JIR27NPT...	0.66	0.6	0.8	-	NVR..-2
		18	2JIR18NPT...	1.01	0.6	0.8		
		14	2JIR14NPT...	1.33	0.9	1.2		
3/8"	16	27	3IR27NPT...	0.66	0.7	0.8	Y13	AVR..-3
		18	3IR18NPT...	1.01	0.8	1.0		
		14	3IR14NPT...	1.33	0.9	1.2		
		11.5	3IR11.5NPT...	1.64	1.1	1.5		
		8	3IR8NPT...	2.42	1.3	1.8		
3/8" SCB	16	27	3JIR27NPT...	0.66	0.6	0.8	Y13	AVR..-3
		18	3JIR18NPT...	1.01	0.6	0.8		
		14	3JIR14NPT...	1.33	1.1	1.5		
		11.5	3JIR11.5NPT...	1.64	1.1	1.5		
		8	3JIR8NPT...	2.42	1.0	1.5		

* For related holders see pages 60-61.

NPT (con't)

Internal

Defined by: USAS B2.1:1968
Tolerance class: Standard NPT

M+ Style

F-Line

Z+ Style

M+ Style



Insert Size		Pitch	Teeth	Ordering Code	Dimensions mm			Anvil	
IC	L mm	TPI		RH	h min	X	Y	RH	Toolholder*
3/8"	16	14	2	3IR14NPT2M+...	1.33	2.0	3.0	YI3M	AVR..-3
1/2"	22	11.5	2	4IR11.5NPT2M+...	1.64	2.2	3.4	YI4M	AVR..-4
5/8"	27	11.5	3	5IR11.5NPT3M+...	1.64	3.5	5.6	YI5M	AVR..-5M
		8	2	5IR8NPT2M+...	2.42	3.1	4.9		

* For related holders see pages 60-61 | page 64.

Z+ Style



Insert Size		Pitch	Teeth	Ordering Code	Dimensions mm			Anvil	
IC	L mm	TPI		RH	h min	X	Y	RH	Toolholder*
1/2"	22	11.5	2	4IR11.5NPT2Z+...	1.64	2.7	10.0	YI4Z	AVR..-4Z
		8	2	4IR8NPT2Z+...	2.42	3.4	9.6		

* For related holders see page 62.

F LINE M+ Style



Insert Size		Pitch	Teeth	Ordering Code	Dimensions mm			Anvil	
IC	L mm	TPI		RH	h min	X	Y	RH	Toolholder*
1/2" F	23	11.5	2	4FIR11.5NPT2M+...	1.64	2.2	3.4	YI4M2F	AVRC...-4MF

* For related holders see page 63.

ТОВ «СМАРТТЕК ІНЖИНІРИНГ», Т. +380-50-396-90-96, info@smarttec.com.ua, https://www.smarttec.com.ua

NPTF

External

Defined by: ANSI B1.20.3-1976
Tolerance class: Standard NPT

MACH TT Standard SCB Sintered Chipbreaker M+ Style



Insert Size		Pitch	Ordering Code	Dimensions mm			Anvil	
IC	L mm	TPI	RH	h min	X	Y	RH	Toolholder*
3/8"	16	27	3DTER27NPTF...	0.64	1.6	0.8	YE3	AL...3DT
		18	3DTER18NPTF...	1.00	1.5	1.4		
		14	3DTER14NPTF...	1.35	1.5	1.4		
		11.5	3DTER11.5NPTF...	1.63	1.5	1.4		
		8	3DTER8NPTF...	2.38	1.2	1.7		

* For related holders see pages 46-47.

Standard



SCB

Insert Size		Pitch	Ordering Code	Dimensions mm			Anvil	
IC	L mm	TPI	RH	h min	X	Y	RH	Toolholder*
1/4"	11	27	2ER27NPTF...	0.64	0.7	0.8	-	NL...2
		18	2ER18NPTF...	1.00	0.8	1.0		
		14	2ER14NPTF...	1.35	0.8	1.0		
3/8"	16	27	3ER27NPTF...	0.64	0.7	0.8	YE3	AL...3
		18	3ER18NPTF...	1.00	0.8	1.0		
		14	3ER14NPTF...	1.35	0.9	1.2		
		11.5	3ER11.5NPTF...	1.63	1.1	1.5		
3/8" SCB	16	27	3JER27NPTF...	0.64	0.7	0.8	YE3	AL...3
		18	3JER18NPTF...	1.00	0.6	0.8		
		14	3JER14NPTF...	1.35	1.1	1.5		
		11.5	3JER11.5NPTF...	1.63	1.1	1.5		
		8	3JER8NPTF...	2.38	1.1	1.5		

* For related holders see pages 48-49.

M+ Style



Insert Size		Pitch	Teeth	Ordering Code	Dimensions mm			Anvil	
IC	L mm	TPI		RH	h min	X	Y	RH	Toolholder*
3/8"	16	14	2	3ER14NPTF2M+...	1.35	2.0	3.0	YE3M	AL...3

* For related holders see pages 48-49.



NPTF (con't)

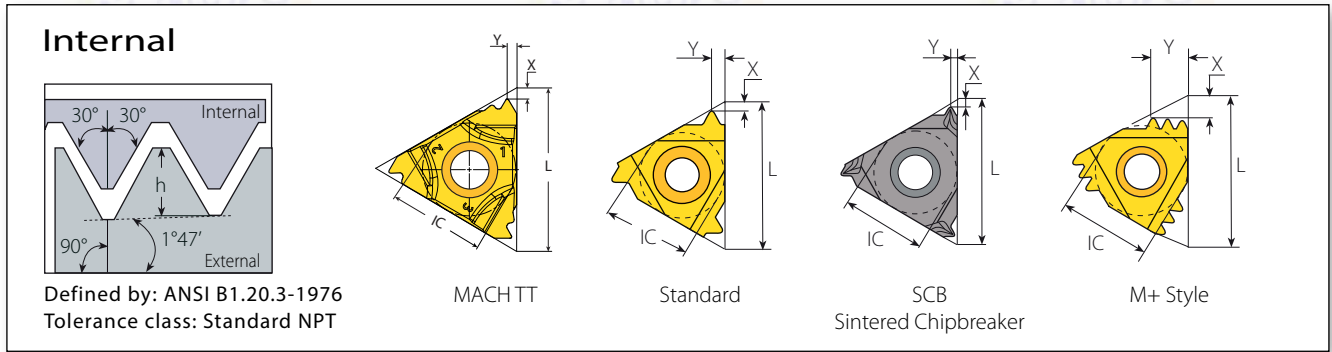

Insert Size		Pitch	Ordering Code		Dimensions mm			Anvil	
IC	L mm	TPI	RH		h min	X	Y	RH	Toolholder*
3/8"	16	27	3DTIR27NPTF...		0.64	1.3	0.6	Y13	.VRC...-3DT
		18	3DTIR18NPTF...		1.00	1.2	1.0		
		14	3DTIR14NPTF...		1.35	1.2	1.0		
		11.5	3DTIR11.5NPTF...		1.63	1.2	1.3		
		8	3DTIR8NPTF...		2.38	1.2	1.7		

* For related holders see pages 57-59.

Standard

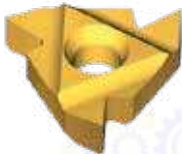

SCB

Insert Size		Pitch	Ordering Code		Dimensions mm			Anvil	
IC	L mm	TPI	RH		h min	X	Y	RH	Toolholder*
1/4"	11	27	2IR27NPTF...		0.64	0.7	0.8	-	NVR...-2
		18	2IR18NPTF...		1.00	0.8	1.0		
		14	2IR14NPTF...		1.35	0.8	1.0		
1/4" SCB	11	27	2JIR27NPTF...		0.64	0.7	0.8	-	NVR...-2
		18	2JIR18NPTF...		1.00	0.6	0.8		
3/8"	16	27	3IR27NPTF...		0.64	0.7	0.8	Y13	AVR...-3
		18	3IR18NPTF...		1.00	0.8	1.0		
		14	3IR14NPTF...		1.35	0.9	1.2		
		11.5	3IR11.5NPTF...		1.63	1.1	1.5		
		8	3IR8NPTF...		2.38	1.3	1.8		
3/8" SCB	16	27	3JIR27NPTF...		0.64	0.7	0.8	Y13	AVR...-3
		18	3JIR18NPTF...		1.00	0.6	0.8		
		14	3JIR14NPTF...		1.35	1.1	1.5		
		11.5	3JIR11.5NPTF...		1.63	1.1	1.5		
		8	3JIR8NPTF...		2.38	1.1	1.5		

* For related holders see pages 60-61.

M+ Style



Insert Size		Pitch	Teeth	Ordering Code		Dimensions mm			Anvil	
IC	L mm	TPI		RH		h min	X	Y	RH	Toolholder*
3/8"	16	14	2	3IR14NPTF2M+...		1.35	2.0	3.0	Y13M	AVR...-3

* For related holders see pages 60-61.

American ACME

External

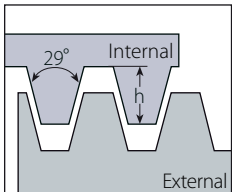

Defined by:
ANSI B1.5:1988
Tolerance class: 3G

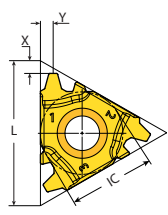

MACH TT

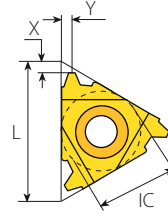

Standard

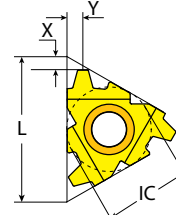

F-Line



Insert Size	Pitch		Ordering Code		Dimensions mm			Anvil	
	IC	L mm	TPI	RH	h min	X	Y	RH	Toolholder*
1/2"	22	7	4DTER7ACME...		2.08	2.1	2.2	YE4	AL...-4DT
		6	4DTER6ACME...		2.37	1.9	2.1		
		5	4DTER5ACME...		2.79	1.9	2.2		

* For related holders see pages 46-47.

Standard

Insert Size	Pitch		Ordering Code		Dimensions mm			Anvil	
	IC	L mm	TPI	RH	h min	X	Y	RH	Toolholder*
1/4"	11	16	2ER16ACME...		0.92	1.0	1.1	-	NL...-2
3/8"		16	3ER16ACME...		0.92	1.0	1.1		
		14	3ER14ACME...		1.03	1.1	1.2		
	12	3ER12ACME...		1.19	1.2	1.3			
	10	3ER10ACME...		1.52	1.3	1.4			
	8	3ER8ACME...		1.84	1.4	1.5			
1/2"	22	7	3ER7ACME...		2.08	1.9	2.2	YE3	AL...-3
		6	3ER6ACME...		2.37	1.7	1.9		
		7	4ER7ACME...		2.08	1.9	2.2		
5/8"	27	6	3ER6ACME...		2.37	1.7	1.9	YE4	AL...-4
		5	4ER5ACME...		2.79	2.0	2.3	YE5	AL...-5

* For related holders see pages 48-49.

F-LINE

Insert Size	Pitch		Ordering Code		Dimensions mm			Anvil	
	IC	L mm	TPI	RH	h min	X	Y	RH	Toolholder*
1/2" F	23	6	4FER6ACME...		2.37	1.8	2.1	YE4F	AL...-4F
		5	4FER5ACME...		2.79	2.0	2.3		

* For related holders see page 51.



American ACME (con't)

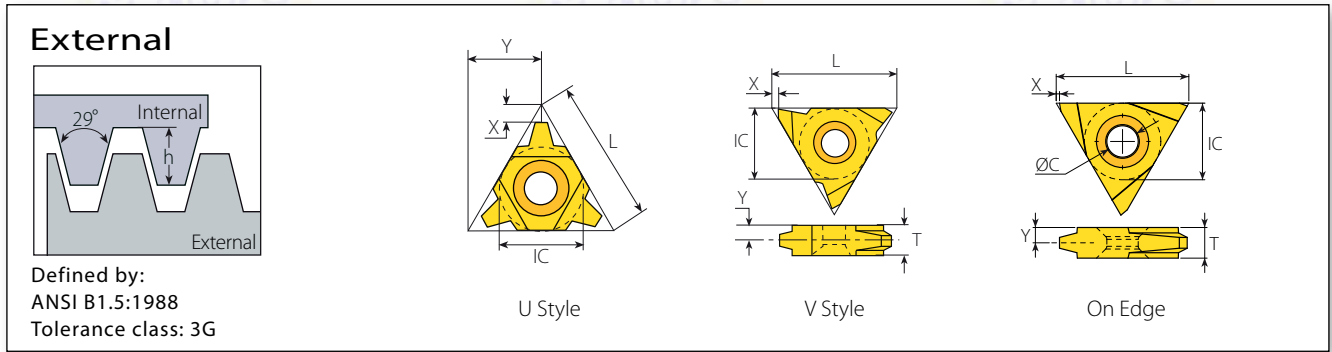

U Style



Insert Size		Pitch	Ordering Code	Dimensions mm			Anvil	Toolholder*
IC	L mm	TPI	RH+LH	h min	X	Y	RH	
1/2"U	22	3	4UE3ACME...	4.49	3.0	11.0	YE4U	AL...-4U
		4	4UE4ACME...	3.43	2.3	11.0		
5/8"U	27	3	5UE3ACME...	4.49	3.0	13.7	YE5U	AL...-5U

* For related holders see page 55.

V Style



Insert Size		Pitch	Ordering Code	Dimensions mm				Toolholder*
IC	L mm	TPI	RH	h min	X	Y	T	
5/8"V	27	4	5VER4ACME...	3.43	1.0	3.3	6	NL...-5V-6
		3.5	5VER3.5ACME...	3.85	1.0	3.3	6	
		3	5VER3ACME...	4.49	1.0	3.3	6	
		2	5VER2ACME...	6.60	1.0	5.2	10	

* For related holders see page 56.

On Edge*



Insert Size		Pitch	Ordering Code	Dimensions mm				
IC	L mm	TPI	RH	h min	T	ØC	X	Y
1/2"	22	4	TNEC43EI4ACME...	3.43	4.76	5.2	0.5	2.4
		6	TNEC43EI6ACME...	2.36				
		8	TNEC43EI8ACME...	1.83				
		10	TNEC43EI10ACME...	1.52				
		12	TNEC43EI12ACME...	1.19				
5/8"	27	4	TNEC54EI4ACME...	3.43	6.35	6.5		3.2
		3	TNEC54EI3ACME...	4.50				
3/4"	32	2	TNEC56EI2ACME...	6.60	9.53	8.0		4.8

* On Edge inserts are compatible with existing holders on the market.

American ACME (con't)

Internal

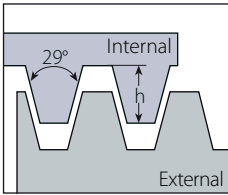

Defined by:
ANSI B1.5:1988
Tolerance class: 3G

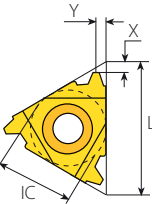

Standard

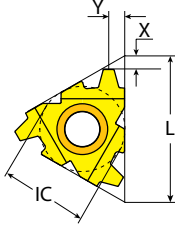

F-Line

Standard



Insert Size		Pitch	Ordering Code	Dimensions mm			Anvil	Toolholder*
IC	L mm	TPI	RH	h min	X	Y	RH	
1/4"	11	16	2IR16ACME...	0.92	0.9	0.9	-	NVR..-2
		16	3IR16ACME...	0.92	1.0	1.1		
3/8"	16	14	3IR14ACME...	1.03	1.1	1.2		
		12	3IR12ACME...	1.19	1.2	1.3	Y13	AVR..-3
		10	3IR10ACME...	1.52	1.2	1.3		
		8	3IR8ACME...	1.84	1.4	1.5		
		6	3IR6ACME...	2.37	1.7	1.9	Y13AC6	
1/2"	22	6	4IR6ACME...	2.37	1.8	2.1	Y14	AVR..-4
		5	4IR5ACME...	2.79	2.0	2.3		
5/8"	27	4	5IR4ACME...	3.43	2.3	2.6	Y15	AVR..-5

* For related holders see pages 60-61.

F-LINE



Insert Size		Pitch	Ordering Code	Dimensions mm			Anvil	Toolholder*
IC	L mm	TPI	RH	h min	X	Y	RH	
1/2" F	23	6	4FIR6ACME...	2.37	1.8	2.1	Y14F	AVRC...-4F
		5	4FIR5ACME...	2.79	2.0	2.3		

* For related holders see page 63.

American ACME (con't)

Internal

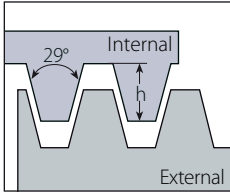

Defined by:
ANSI B1.5:1988
Tolerance class: 3G

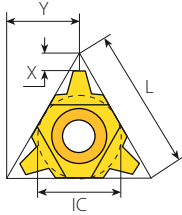

U Style

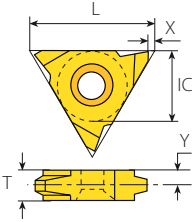

V Style

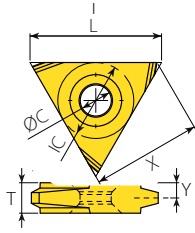

On Edge

U Style



Insert Size		Pitch	Ordering Code	Dimensions mm			Anvil	
IC	L mm	TPI	RH+LH	h min	X	Y	RH	Toolholder*
1/2"U	22	4	4UI4ACME...	3.43	2.3	11.0	Y14U	AVR..-4U
		3	4UI3ACME...	4.49	2.9	11.0		
5/8"U	27	3	5UI3ACME...	4.49	2.9	13.7	Y15U	AVR..-5U

* For related holders see page 67.

V Style



Insert Size		Pitch	Ordering Code	Dimensions mm				
IC	L mm	TPI	RH	h min	X	Y	T	Toolholder*
5/8"V	27	4	5VIR4ACME...	3.43	1.0	3.3	6	NVR..-5V
		3.5	5VIR3.5ACME...	3.85	1.0	3.3	6	
		3	5VIR3ACME...	4.49	1.0	3.3	6	
		2	5VIR2ACME...	6.60	1.0	5.2	10	

* For related holders see page 68.

On Edge*



Insert Size		Pitch	Ordering Code	Dimensions mm					
IC	L mm	TPI	RH	h min	T	ØC	X	Y	
1/2"	22	4	TNEC43EI4ACME...	3.43	4.76	5.2	18.64	2.38	
		6	TNEC43EI6ACME...	2.36					
		8	TNEC43EI8ACME...	1.83					
		10	TNEC43EI10ACME...	1.52					
5/8"	27	4	TNEC54EI4ACME...	3.43	6.35	6.5	18.64	3.2	
		3	TNEC54EI3ACME...	4.50					
3/4"	32	2	TNEC56EI2ACME...	6.60	9.53	8.0	18.64	4.8	

* On Edge inserts are compatible with existing holders on the market.

Stub ACME

External

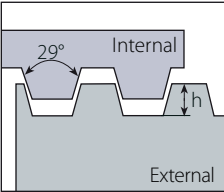

Defined by:
ANSI B1.8:1988
Tolerance class: 2G

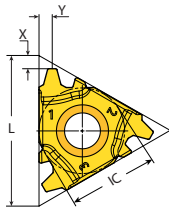

MACH TT

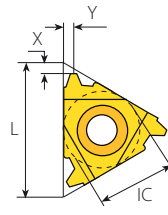

Standard

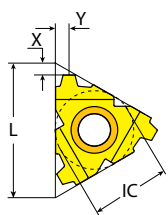

F-Line



Insert Size		Pitch	Ordering Code	Dimensions mm			Anvil	
IC	L mm	TPI	RH	h min	X	Y	RH	Toolholder*
1/2"	22	7	4DTER7ACME...	2.08	2.1	2.2	YE4	AL...-4DT
		6	4DTER6ACME...	2.37	1.9	2.1		
		5	4DTER5ACME...	2.79	1.9	2.2		

* For related holders see pages 46-47.

Standard



Insert Size		Pitch	Ordering Code	Dimensions mm			Anvil	
IC	L mm	TPI	RH	h min	X	Y	RH	Toolholder*
1/4"	11	16	2ER16STACME...	0.60	1.0	1.0	-	NL..-2
		16	3ER16STACME...	0.60	1.0	1.0		
		14	3ER14STACME...	0.67	1.1	1.1		
3/8"	16	12	3ER12STACME...	0.76	1.2	1.2	YE3	AL..-3
		10	3ER10STACME...	1.02	1.2	1.3		
		8	3ER8STACME...	1.21	1.4	1.5		
		6	3ER6STACME...	1.52	1.7	1.8		
1/2"	22	6	4ER6STACME...	1.52	1.7	1.8	YE4	AL..-4
		5	4ER5STACME...	1.78	2.1	2.3		
		4	4ER4STACME...	2.16	2.3	2.3		
5/8"	27	4	5ER4STACME...	2.16	2.3	2.4	YE5	AL..-5
		3	5ER3STACME...	2.79	2.9	2.9		

* For related holders see pages 48-49.

F-LINE



Insert Size		Pitch	Ordering Code	Dimensions mm			Anvil	
IC	L mm	TPI	RH	h min	X	Y	RH	Toolholder*
1/2" F	23	6	4FER6STACME...	1.52	1.7	1.8	YE4F	AL...-4F
		5	4FER5STACME...	1.78	2.1	2.3		
		4	4FER4STACME...	2.16	2.3	2.3		

* For related holders see page 51.

Stub ACME (con't)

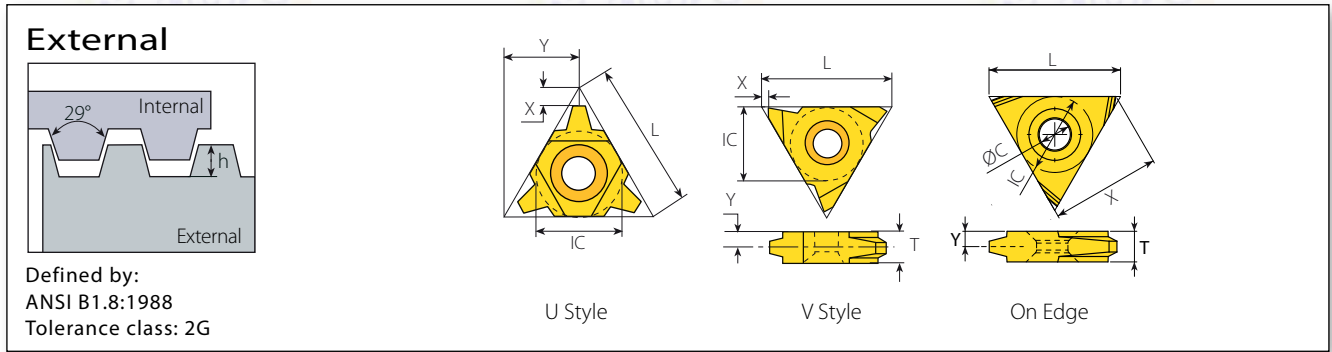

U Style



Insert Size		Pitch	Ordering Code	Dimensions mm			Anvil	Toolholder*
IC	L mm	TPI	RH+LH	h min	X	Y	RH	
1/2"U	22	4	4UE4STACME...	2.16	2.6	11.0	YE4U	AL...4U
		3	4UE3STACME...	2.79	3.4	11.0		

* For related holders see page 55.

V Style



Insert Size		Pitch	Ordering Code	Dimensions mm					Toolholder*
IC	L mm	TPI	RH	h min	X	Y	T		
5/8"V	27	4	5VER4STACME...	2.16	1.0	3.3	6	NL...5V-6	
		3	5VER3STACME...	2.79	1.0	3.3	6		
		2	5VER2STACME...	4.06	1.0	4.3	6		NL...5V-8

* For related holders see page 56.

On Edge*



Insert Size		Pitch	Ordering Code	Dimensions mm					
IC	L mm	TPI	RH	h min	T	ØC	X	Y	
3/8"	16	10	TNEC32EI10STACME...	1.02	3.18	3.8	1	1.6	
		12	TNEC32EI12STACME...	0.76					
		8	TNEC32EI8STACME...	1.22					
1/2"	22	4	TNEC43EI4STACME...	2.16	4.76	5.2	0.5	2.4	
		6	TNEC43EI6STACME...	1.52					
		8	TNEC43EI8STACME...	1.22					
		10	TNEC43EI10STACME...	1.02					
5/8"	27	12	TNEC43EI12STACME...	0.76	6.35	6.5		3.2	
		4	TNEC54EI4STACME...	2.16					

* On Edge inserts are compatible with existing holders on the market.

Stub ACME (con't)

Internal

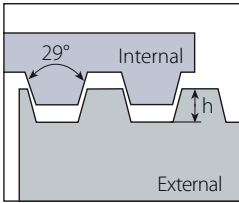

Defined by: ANSI B1.8:1988
Tolerance class: 2G

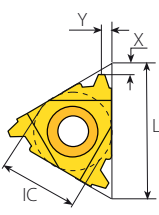

Standard

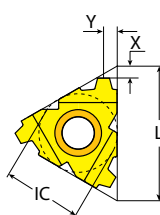

F-Line

Standard



Insert Size		Pitch	Ordering Code	Dimensions mm			Anvil	Toolholder*
IC	L mm	TPI	RH	h min	X	Y	RH	
1/4"	11	16	2IR16STACME...	0.60	1.0	1.0	-	NVR..-2
		16	3IR16STACME...	0.60	1.0	1.0		
		14	3IR14STACME...	0.67	1.1	1.1		
3/8"	16	12	3IR12STACME...	0.76	1.1	1.2	Y13	AVR..-3
		10	3IR10STACME...	1.02	1.2	1.3		
		8	3IR8STACME...	1.21	1.4	1.5		
		6	3IR6STACME...	1.52	1.7	1.8		
1/2"	22	6	4IR6STACME...	1.52	1.7	1.8	Y14	AVR..-4
		5	4IR5STACME...	1.78	2.1	2.3		
5/8"	27	4	5IR4STACME...	2.16	2.3	2.4	Y15	AVR..-5
		3	5IR3STACME...	2.79	2.9	2.9		

* For related holders see pages 60-61.

F-LINE



Insert Size		Pitch	Ordering Code	Dimensions mm			Anvil	Toolholder*
IC	L mm	TPI	RH	h min	X	Y	RH	
1/2" F	23	6	4FIR6STACME...	1.52	1.7	1.8	Y14F	AVRC...-4F
		5	4FIR5STACME...	1.78	2.1	2.3		
		4	4FIR4STACME...	2.16	2.3	2.3		

* For related holders see page 63.

Stub ACME (con't)

Internal

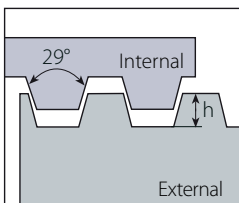

Defined by: ANSI B1.8:1988
Tolerance class: 2G

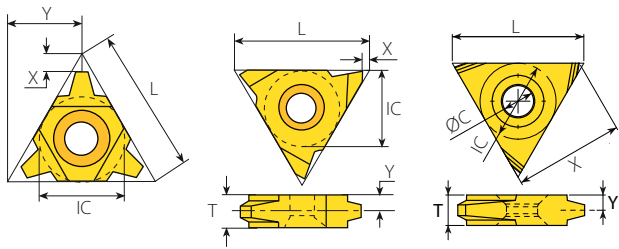

U Style V Style On Edge

U Style



Insert Size		Pitch	Ordering Code	Dimensions mm			Anvil	
IC	L mm	TPI	RH+LH	h min	X	Y	RH	Toolholder*
1/2"U	22	4	4UI4STACME...	2.16	2.5	11.0	Y14U	AVR..-4U
		3	4UI3STACME...	2.79	3.3	11.0		

* For related holders see page 67.

V Style



Insert Size		Pitch	Ordering Code	Dimensions mm				
IC	L mm	TPI	RH	h min	X	Y	T	Toolholder*
5/8"V	27	4	5VIR4STACME...	2.16	1.0	3.3	6	NVR..-5V
		3	5VIR3STACME...	2.79	1.0	3.3	6	
		2	5VIR2STACME...	4.06	1.0	4.3	8	

* For related holders see page 68.

On Edge*



Insert Size		Pitch	Ordering Code	Dimensions mm					
IC	L mm	TPI	RH	h min	T	ØC	X	Y	
3/8"	16	10	TNEC32EI10STACME...	1.02	3.175	3.8	1	1.6	
		12	TNEC32EI12STACME...	0.76					
		8	TNEC32EI8STACME...	1.22					
1/2"	22	4	TNEC43EI4STACME...	2.16	4.76	5.2	0.5	2.4	
		6	TNEC43EI6STACME...	1.52					
		8	TNEC43EI8STACME...	1.22					
		10	TNEC43EI10STACME...	1.02					
		12	TNEC43EI12STACME...	0.76					
5/8"	27	4	TNEC54EI4STACME...	2.16	6.35	6.5		3.2	

* On Edge inserts are compatible with existing holders on the market.

API

External

Defined by: API SPEC. 7:1990
Tolerance class: Standard API

MACH TT

Standard - External



Insert Size	Pitch	Thread	Taper	Ordering Code	Size	Dimensions mm			Anvil		
						IC	L mm	TPI	IPF	RH	h min
1/2"	22	4	V-0.038R	2	4DTER4API382...	NC23-NC50, 2 3/8", 6 5/8" IF	3.09	1.8	2.6	YEI 4-API-1P or YE4	AL...-4DT
		4	V-0.038R	3	4DTER4API383...	NC56-NC77	3.08	1.9	2.6		
		5	V-0.040	3	4DTER5API403...	2 3/8"-4 1/2" REG	2.99	1.8	2.4		
		4	V-0.050	2	4DTER4API502...	6 5/8" REG, 5 1/2" FH, 6 5/8" FH	3.75	1.7	2.7		
		4	V-0.050	3	4DTER4API503...	5 1/2", 7 5/8", 8 5/8" REG	3.74	1.7	2.7		
		6	V-0.055	1.5	4DTER6API551...	NC10-NC16	1.41	1.8	2.6		

* For related holders see pages 46-47.

Standard

Insert Size	Pitch	Thread	Taper	Ordering Code	Size	Dimensions mm			Anvil		
						IC	L mm	TPI	IPF	RH	h min
1/2"	22	4	V-0.038R	2	4ER4API382...	NC23-NC50, 2 3/8" - 6 5/8" IF	3.09	2.1	2.8	YEI 4-API-1P or YE4	AL...-4 5BUT/API or AL...-4
		4	V-0.038R	3	4ER4API383...	NC56-NC77	3.08	2.1	2.8		
		5	V-0.040	3	4ER5API403...	2 3/8"-4 1/2" REG	2.99	1.8	2.6		
		4	V-0.050	2	4ER4API502...	6 5/8" REG, 5 1/2" FH, 6 5/8" FH	3.75	2.0	2.9		
		4	V-0.050	3	4ER4API503...	5 1/2", 7 5/8", 8 5/8" REG	3.74	2.0	2.9		
		6	V-0.055	1.5	4ER6API551...	NC10-NC16	1.41	2.6	2.0		
5/8"	27	4	V-0.038R	2	5ER4API382...	NC23-NC50, 2 3/8" - 6 5/8" IF	3.09	2.1	2.8	YE50IL	AL...-5 OIL
		4	V-0.038R	3	5ER4API383...	NC56-NC77	3.08	2.1	2.8		
		5	V-0.040	3	5ER5API403...	2 3/8"-4 1/2" REG	2.99	1.9	2.7		
		4	V-0.050	2	5ER4API502...	6 5/8" REG, 5 1/2" FH, 6 5/8" FH	3.75	2.1	3.1		
		4	V-0.050	3	5ER4API503...	5 1/2", 7 5/8", 8 5/8" REG	3.74	2.1	3.1		

* For related holders see pages 49-50.

API (con't)

External

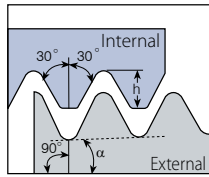

$$\alpha = \arctg (IPF/24)$$

Defined by: API SPEC. 7:1990
Tolerance class: Standard API

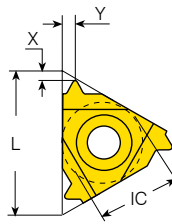

F-Line

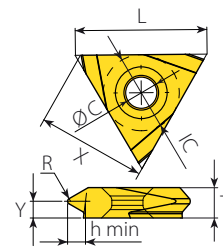

On Edge

F LINE



IC	L mm	TPI	IPF	RH	Size	Dimensions mm			Anvil	Toolholder*	
						h min	X	Y			
1/2" F	23	4	V-0.038R	2	4FER4API382...	NC23-NC50, 2 3/8"-6 5/8" IF	3.09	2.1	2.8	YE4F	AL...-4F
		4	V-0.038R	3	4FER4API383...	NC56-NC77	3.08	2.1	2.8		
		5	V-0.040	3	4FER5API403...	2 3/8"-4 1/2" REG	2.99	1.8	2.6		
		4	V-0.050	2	4FER4API502...	6 5/8" REG, 5 1/2" FH, 6 5/8" FH	3.75	2	2.9		
		4	V-0.050	3	4FER4API503...	5 1/2", 7 5/8", 8 5/8" REG	3.74	2	2.9		
		6	V-0.055	1.5	4FER6API551...	NC10-NC16	1.41	2.6	2		

* For related holders see page 51.

On Edge*



IC	L mm	TPI	IPF	RH	Size	Dimensions mm				Position		
						R	h min	T	ØC	X	Y	
5/8"	27	4	V-0.038R	2	TNEC55ER4API382...	NC23-NC50, 2 3/8" - 6 5/8" IF	0.97	3.10	7.94	6.50	23.4	5.0
		4	V-0.038R	3	TNEC55ER4API383...	NC56-NC77	0.97	3.10	7.94			5.0
		5	V-0.040	3	TNEC54ER5API403...	2 3/8"-4 1/2" REG	0.51	3.00	6.35			3.9
		4	V-0.050	2	TNEC55ER4API 502...	6 5/8" REG, 5 1/2" FH, 6 5/8" FH	0.64	3.76	7.94			5.0
		4	V-0.050	3	TNEC55ER4API503...	5 1/2", 7 5/8", 8 5/8" REG	0.64	3.76	7.94			5.0

* On Edge inserts are compatible with existing holders on the market.

API (con't)

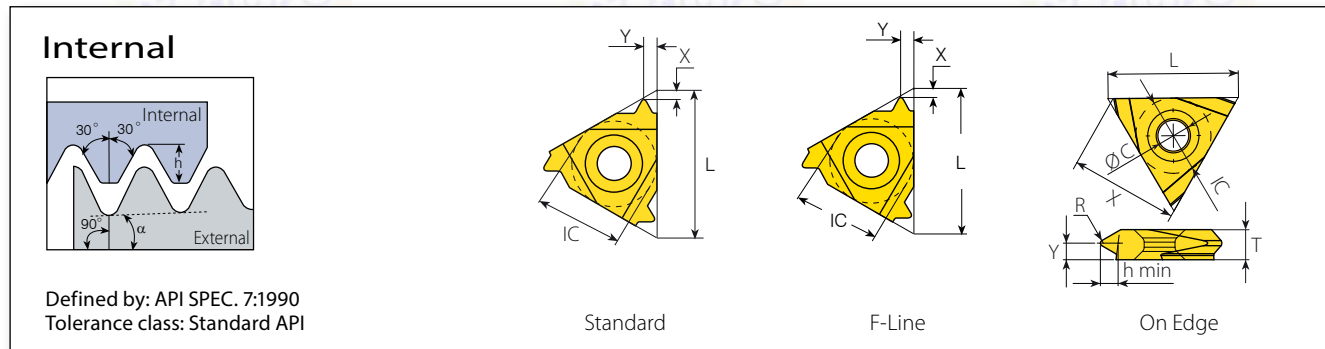

Standard

Insert Size	Pitch		Thread	Taper	Ordering Code		Size	Dimensions mm			Anvil	
	IC	L mm			TPI	IPF		RH	h min	X	Y	RH
1/2"	22	4	V-0.038R	2	4IR4API382...	NC23-NC50, 2 3/8" - 6 5/8" IF	3.09	2.1	2.8	YEI 4-API-1P or YE4	AVRC-.45BUT/API or AVR...-4	
		4	V-0.038R	3	4IR4API383...	NC56-NC77	3.08	2.1	2.8			
		5	V-0.040	3	4IR5API403...	2 3/8"-4 1/2" REG	2.99	1.8	2.6			
		4	V-0.050	2	4IR4API502...	6 5/8" REG, 5 1/2" FH, 6 5/8" FH	3.75	2.1	3.1			
		4	V-0.050	3	4IR4API503...	5 1/2", 7 5/8", 8 5/8" REG	3.74	2.0	2.9			
5/8"	27	4	V-0.038R	2	5IR4API382...	NC23-NC50, 2 3/8" - 6 5/8" IF	3.09	2.1	2.8	YI50IL	AVR..-5 OIL	
		4	V-0.038R	3	5IR4API383...	NC56-NC77	3.08	2.1	2.8			
		5	V-0.040	3	5IR5API403...	2 3/8"-4 1/2" REG	2.99	1.9	2.7			
		4	V-0.050	2	5IR4API502...	6 5/8" REG, 5 1/2" FH, 6 5/8" FH	3.75	2.1	3.1			
		4	V-0.050	3	5IR4API503...	5 1/2", 7 5/8", 8 5/8" REG	3.74	2.1	3.1			

* For related holders see page 62.

F-LINE

Insert Size	Pitch		Thread	Taper	Ordering Code		Size	Dimensions mm			Anvil	
	IC	L mm			TPI	IPF		RH	h min	X	Y	RH
1/2" F	23	4	V-0.038R	2	4FIR4API382...	NC23-NC50, 2 3/8" - 6 5/8" IF	3.09	2.1	2.8	YI4F	AVRC...-4F	
		4	V-0.038R	3	4FIR4API383...	NC56-NC77	3.08	2.1	2.8			
		5	V-0.040	3	4FIR5API403...	2 3/8"-4 1/2" REG	2.99	1.8	2.6			
		4	V-0.050	2	4FIR4API502...	6 5/8" REG, 5 1/2" FH, 6 5/8" FH	3.75	2.1	3.1			
		4	V-0.050	3	4FIR4API503...	5 1/2", 7 5/8", 8 5/8" REG	3.74	2	2.9			
6	V-0.055	1.5	4FIR6API551...	NC10-NC16	1.41	2.6	2					

* For related holders see page 63.

On Edge*

Insert Size	Pitch		Thread	Taper	Ordering Code		Size	Dimensions mm				Position	
	IC	L mm			TPI	IPF		RH	R	h min	T	Ø C	X
5/8"	27	4	V-0.038R	2	TNEC55IR4API382...	NC23-NC50, 2 3/8" - 6 5/8" IF	0.97	3.10	7.94	6.50	23.4	3.9	
		4	V-0.038R	3	TNEC55IR4API383...	NC56-NC77	0.97	3.10	7.94				
		5	V-0.040	3	TNEC54IR5API403...	2 3/8"-4 1/2" REG	0.51	3.00	6.35				
		4	V-0.050	2	TNEC55IR4API502...	6 5/8" REG, 5 1/2" FH, 6 5/8" FH	0.64	3.76	7.94				
		4	V-0.050	3	TNEC55 IR4API503...	5 1/2", 7 5/8", 8 5/8" REG	0.64	3.76	7.94				

* On Edge inserts are compatible with existing holders on the market.



API Buttress Casing

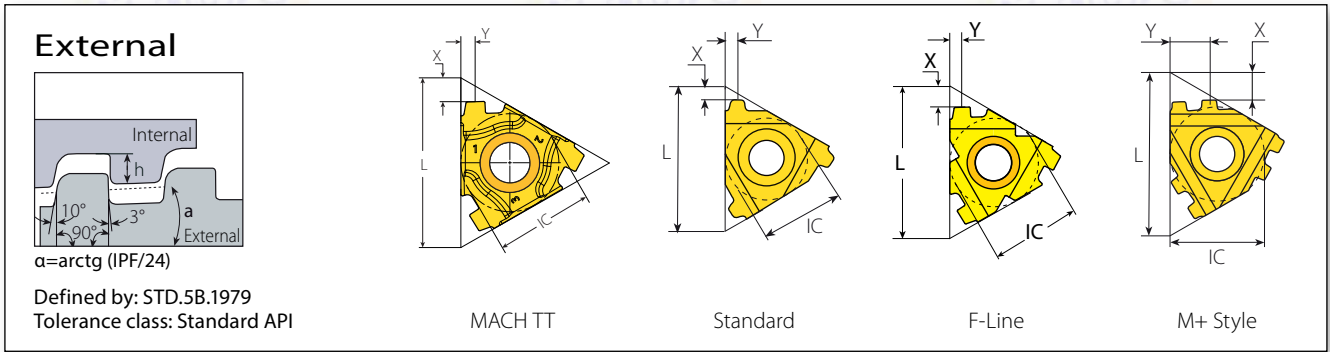

IC	Insert Size		Pitch	Taper	Ordering Code	Size	Dimensions mm			Anvil	Toolholder*
	L mm	TPI	IPF	RH	h min	X	Y	RH			
1/2"	22	5	0.75	4DTER5BUT75...	4 1/2"-13 3/8"	1.55	3.1	1.9	YEI 4-BUT or YE4	AL...-4DT	
		5	1	4DTER5BUT1...	16"-20"	1.55	3.1	1.9			

* For related holders see pages 46-47.

Standard

IC	Insert Size		Pitch	Taper	Ordering Code	Size	Dimensions mm			Anvil	Toolholder*
	L mm	TPI	IPF	RH	h min	X	Y	RH			
1/2"	22	5	0.75	4ER5BUT75...	4 1/2"-13 3/8"	1.55	3.1	1.9	YEI 4-BUT YE4	AL...-4 5BUT/API AL...-4	
		5	1	4ER5BUT1...	16"-20"						

* For related holders see pages 49-50.

F LINE

IC	Insert Size		Pitch	Taper	Ordering Code	Size	Dimensions mm			Anvil	Toolholder*
	L mm	TPI	IPF	RH	h min	X	Y	RH			
1/2" F	23	5	0.75	4FER5BUT75...	4 1/2"-13 3/8"	1.57	3.1	1.9	YE4F	AL...-4F	
		5	1	4FER5BUT1...	16"-20"	1.57	3.1	1.9			

* For related holders see page 51.

M+ Style

IC	Insert Size		Pitch	Taper	Teeth	Ordering Code	Size	Dimensions mm			Anvil	Toolholder*
	L mm	TPI	IPF	RH	h min	X	Y	RH				
5/8"	27	5	0.75	2	5ER5BUT752M+...	4 1/2"-13 3/8"	1.55	4.8	6.8	YE5M	AL...-5M	

* For related holders see pages 48-49.

ТОВ «СМАРТТЕК ІНЖИНІРИНГ», т. +380-50-396-90-96, info@smarttec.com.ua, https://www.smarttec.com.ua



API Buttress Casing (con't)

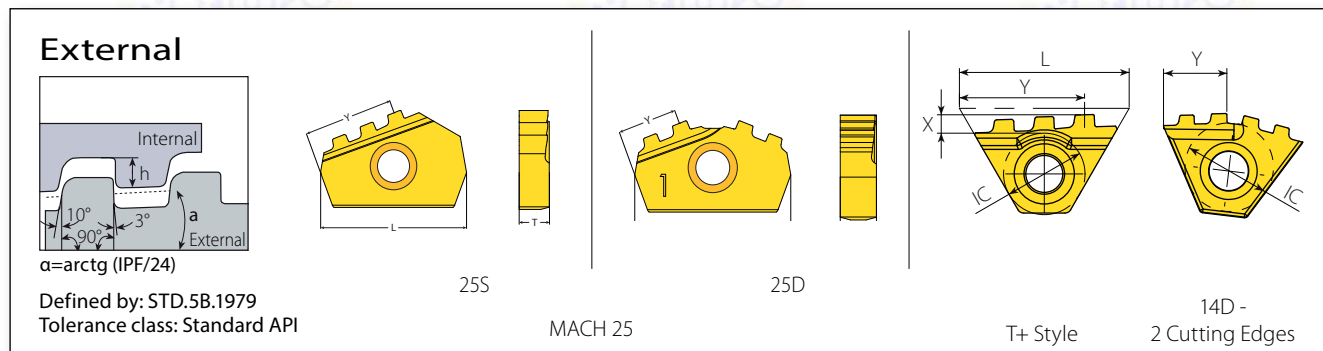

Insert Style	Insert Size	Pitch	Teeth	Ordering Code	Size	Dimensions mm			Anvil		
						L mm	TPI	IPF	RH	h min	Y
25S	25	5	0.75	3	25SER5BUT75-3TH...	4 1/2" - 13 3/8"	1.55	15.2	5	YE25M	ALC..-25DT

Insert Style	Insert Size	Pitch	Teeth	Ordering Code	Size	Dimensions mm			Anvil		
						L mm	TPI	IPF	RH	h min	Y
25D	25	5	0.75	2	25DER5BUT75-2TH...	4 1/2" - 13 3/8"	1.55	9.5	5	YE25M	ALC..-25DT

* For related holders see page 52.

14D

Insert Style	Insert Size	Pitch	Taper	Teeth	Ordering Code	Size	Dimensions mm		Anvil	
							IC	TPI	IPF	h min
14D	5	0.75	2	14DER5BUT752T+...	4 1/2"-9 5/8"	1.55	10.0	Y14DER-5 BUT	AL...-14D	
14D	5	1	2	14DER5BUT12T+...	16"-20"			Y14DER-5BUT-4N	AL...-14D	

* For related holders see page 53.

T+ Style

Insert Style	Insert Size	Pitch	Taper	Teeth	Ordering Code	Size	Dimensions mm			Anvil	
							IC	L mm	TPI	IPF	RH
1/2"T	22	5	0.75	3	4ER5BUT753T+...	4 1/2"-13 3/8"	1.55	2.5	16.1	Y4T	AL...-4T

* For related holders see page 54.



API Buttress Casing (con't)

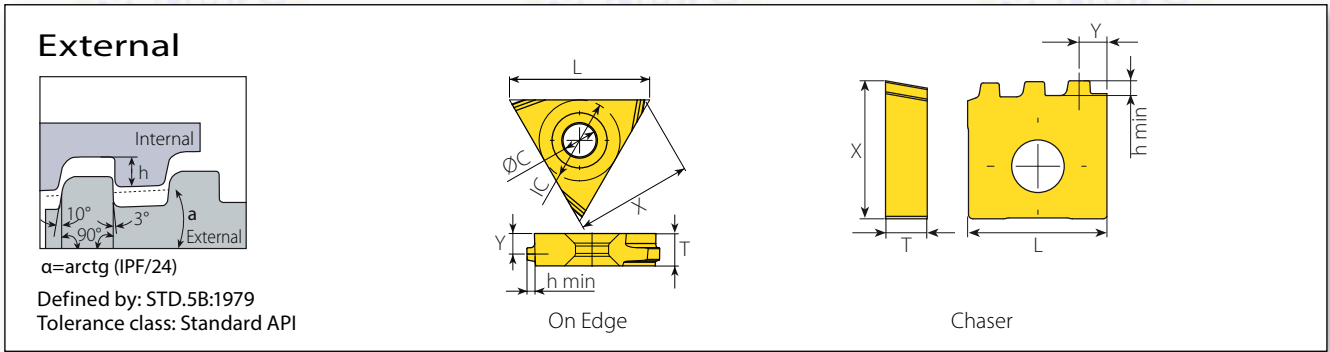

On Edge*



Insert Size		Pitch	Taper	Ordering Code	Size	Dimensions mm			Position	
IC	L mm	TPI	IPF	RH		h min	T	$\varnothing C$	X	Y
5/8"	27	5	0.75	TNEC54ER5BUT75...	4 1/2"-13 3/8"	1.55	6.35	6.5	23.4	4.0
		5	1	TNEC54ER5BUT1...	16"-20"					

* On Edge inserts are compatible with existing holders on the market.

Chaser*



Insert Size		Pitch	Taper	Teeth	Ordering Code	Size	Dimensions mm			Position	
L	TPI	IPF		RH		h min	T	X	Y		
15.75	5	0.75	3	1616ER5BUT753S+...	4 1/2"-13 3/8"	1.55	4.76	15.7	3.2		
	5	1	3	1616ER5BUT13S+ ...	16"-20"						

* Chaser inserts are compatible with existing holders on the market.

API Buttress Casing (con't)

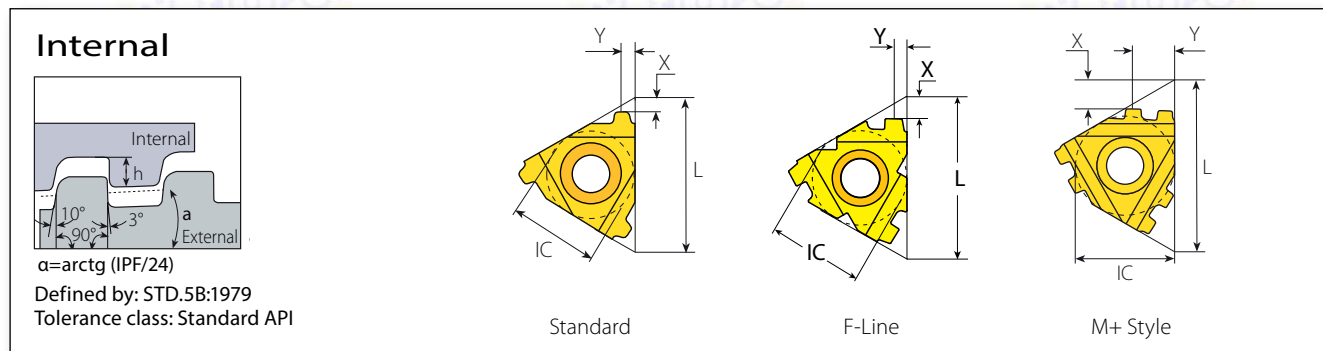

Standard



Insert Size		Pitch	Taper	Ordering Code	Size	Dimensions mm			Anvil	
IC	L mm	TPI	IPF	RH		h min	X	Y	RH	Toolholder*
1/2"	22	5	0.75	4IR5BUT75...	4 1/2"-13 3/8"	1.55	2.8	1.9	YEI 4-BUT YI4	AVRC...-4 5BUT/API AVR...-4
		5	1	4IR5BUT1...	16"-20"					

* For related holders see page 62.

F-LINE



Insert Size		Pitch	Taper	Ordering Code	Size	Dimensions mm			Anvil	
IC	L mm	TPI	IPF	RH		h min	X	Y	RH	Toolholder*
1/2" F	23	5	0.75	4FIR5BUT75...	4 1/2"-13 3/8"	1.57	2.8	1.9	YI4F	AVRC...-4F
		5	1	4FIR5BUT1...	16"-20"					

* For related holders see page 63.

M+ Style



Insert Size		Pitch	Taper	Teeth	Ordering Code	Size	Dimensions mm			Anvil	
IC	L mm	TPI	IPF		RH		h min	X	Y	RH	Toolholder*
5/8"	27	5	0.75	2	5IR5BUT752M+...	4 1/2"-13 3/8"	1.55	4.8	6.7	YI5M	AVR...-5M

* For related holders see page 64.



API Buttress Casing (con't)

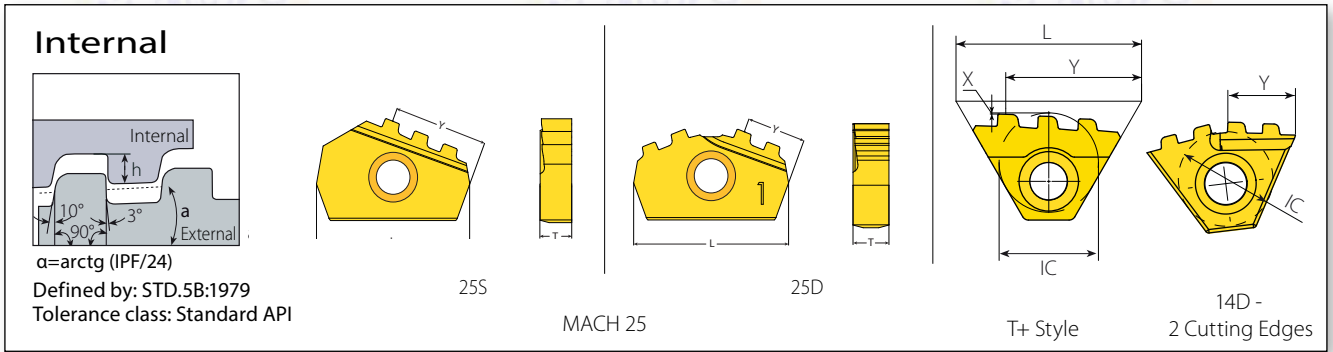

Insert Style	Insert Size	Pitch	Teeth	Ordering Code	Size	Dimensions mm			Anvil	
						L mm	TPI	IPF		h min
25S	25	5	3	25SIR5BUT75-3TH...	4 1/2" - 13 3/8"	1.55	15.2	5	Y125M	AVRC...-25DT
				25SIR5BUT1-3TH...	16" - 20"		15.8			

* For related holders see page 64.

Insert Style	Insert Size	Pitch	Teeth	Ordering Code	Size	Dimensions mm			Anvil	
						L mm	TPI	IPF		h min
25D	25	5	2	25DIR5BUT75-2TH...	4 1/2" - 13 3/8"	1.55	9.9	5	Y125M	AVRC...-25DT
				25DIR5BUT1-2TH...	16" - 20"		9.7			

* For related holders see page 64.

14D

Insert size	Pitch	Taper	Teeth	Ordering Code	Size	Dimensions mm		Anvil	
						IC	TPI		IPF
14D	5	0.75	2	14DIR5BUT752T+ ...	4 1/2"-9 5/8"	1.55	10.0	Y14DIR-5 BUT	AVRC...-14D
					10 3/4"-13 3/8"			Y14DIR-5BUT-4N	
14D	5	1	2	14DIR5BUT12T+ ...	16"-20"	1.55	10.0	Y14DIR-5BUT-4N	AVRC...-14D

* For related holders see page 65.

T+ Style

Insert Size	Pitch	Taper	Teeth	Ordering Code	Size	Dimensions mm			Anvil	
						IC	L mm	TPI		IPF
1/2"T	22	5	3	4IR5BUT753T+...	4 1/2"-13 3/8"	1.55	2.5	16.1	Y4T	AVR...-4T
				4IR5BUT13T+...	16"-20"					

* For related holders see page 66.

API Buttress Casing (con't)

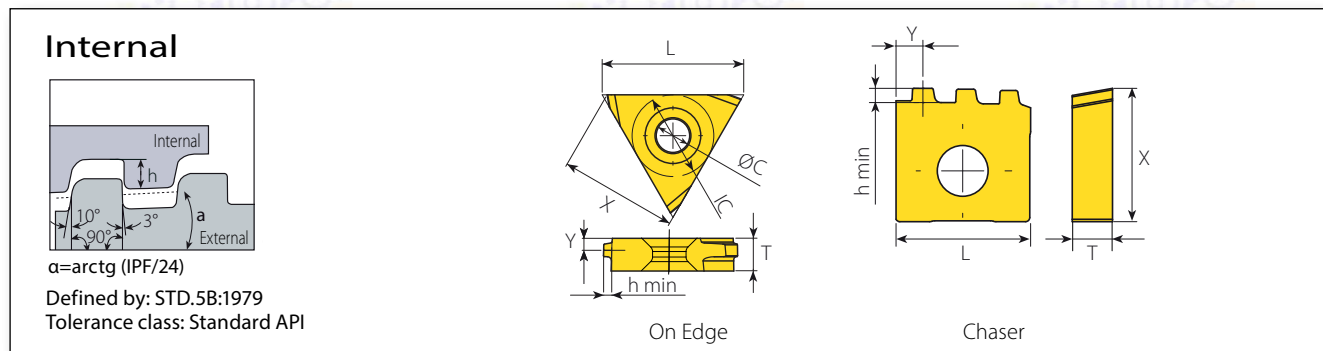

On Edge*



Insert Size		Pitch	Taper	Ordering Code	Size	Dimensions mm			Position	
IC	L mm	TPI	IPF	RH		h min	T	Ø C	X	Y
5/8"	22	5	0.75	TNEC54IR5BUT75...	4 1/2"-13 3/8"	1.55	6.35	6.5	23.4	4.3
		5	1	TNEC54IR5BUT1...	16"-20"					

* On Edge inserts are compatible with existing holders on the market.

Chaser*



Insert Size		Pitch	Taper	Teeth	Ordering Code	Size	Dimensions mm			Position	
L	TPI	IPF		RH		h min	T	X	Y		
15.75	5	0.75	3	1616IR5BUT753S+...	4 1/2"-13 3/8"	1.55	4.76	15.7	3.2		
	5	1	3	1616IR5BUT13S+...	16"-20"						

* Chaser inserts are compatible with existing holders on the market.

API Round Casing & Tubing

External

Defined by: API STD. 5B:1979
Tolerance class: Standard API RD

MACH TT Standard SCB Sintered Chipbreaker M+ Style F-Line



Insert Size		Pitch	Ordering Code	Dimensions mm			Anvil	
IC	L mm	TPI	RH	h min	X	Y	RH	Toolholder*
3/8"	16	10	3DTER10APIRD...	1.41	1.4	1.3	YE3	AL...-3DT
		8	3DTER8APIRD...	1.81	1.3	1.6		

* For related holders see pages 46-47.

Standard



SCB

Insert Size		Pitch	Ordering Code	Dimensions mm			Anvil	
IC	L mm	TPI	RH	h min	X	Y	RH	Toolholder*
3/8"	16	10	3ER10APIRD...	1.41	1.2	1.4	YEI3-APIRD YE3	AL...-3 APIRD AL...-3
		8	3ER8APIRD...	1.81	1.3	1.5		
3/8" SCB	16	10	3JER10APIRD...	1.41	1.2	1.5	YE3	AL...-3
		8	3JER8APIRD...	1.81	1.3	1.5		

* For related holders see pages 48-50.

M+ Style



Insert Size		Pitch	Teeth	Ordering Code	Dimensions mm			Anvil	
IC	L mm	TPI		RH	h min	X	Y	RH	Toolholder*
1/2"	22	10	2	4ER10APIRD2M+...	1.41	2.3	3.8	YE4M	AL...-4
5/8"	27	10	3	5ER10APIRD3M+...	1.41	3.9	6.3	YE5M	AL...-5
		8	2	5ER8APIRD2M+...	1.81	2.9	4.5		

* For related holders see pages 48-49.

F-LINE



Insert Size		Pitch	Teeth	Ordering Code	Dimensions mm			Anvil	
IC	L mm	TPI		RH	h min	X	Y	RH	Toolholder*
1/2" F	23	10	2	4FER10APIRD2M+...	1.41	2.3	3.8	YE4M2F	AL...-4MF

* For related holders see page 52.



SMARTTEK
РОЗУМНІ ТЕХНОЛОГІЇ

ТОВ «СМАРТТЕК ІНЖИНІРИНГ», Т. +380-50-396-90-96, info@smarttec.com.ua, https://www.smarttec.com.ua

API Round Casing & Tubing (con't)

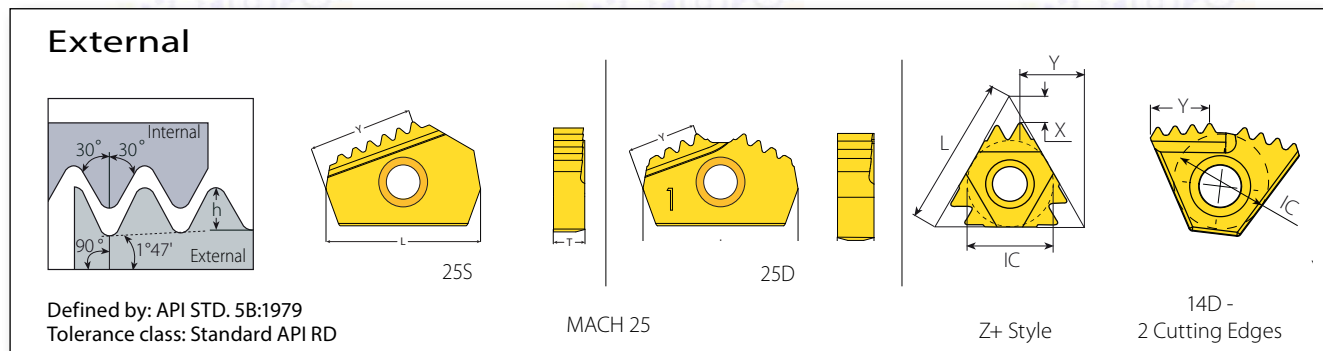

Z+ Style



IC	L mm	Pitch TPI	Teeth	Ordering Code RH	Dimensions mm			Anvil RH	Toolholder*
					h min	X	Y		
1/2"	22	10	2	4ER10APIRD2Z+...	1.41	3.0	9.9	YE4Z	AL..-4Z
		8	2	4ER8APIRD2Z+...	1.81	3.7	9.6		

* For related holders see pages 50-51.



Insert Style	Insert Size L mm	Pitch TPI	Teeth	Ordering Code RH	Dimensions mm			Anvil RH	Toolholder*
					h min	Y	T		
25S	25	10	4	25SER10APIRD-4TH...	1.41	11	5	YE25M	ALC..-25DT
		10	6	25SER10APIRD-6TH...	1.41	16.7			
		8	5	25SER8APIRD-5TH...	1.81	16.8			



Insert Style	Insert Size L mm	Pitch TPI	Teeth	Ordering Code RH	Dimensions mm			Anvil RH	Toolholder*
					h min	Y	T		
25D	25	10	3	25DER10APIRD-3TH...	1.41	8.5	5	YE25M	ALC..-25DT
		10	4	25DER10APIRD-4TH...	1.41	11.0			
		8	3	25DER8APIRD-3TH...	1.81	10.0			

* For related holders see page 52.

14D



Insert size IC	Pitch TPI	Teeth	Ordering Code	Size	Dimensions mm			Anvil	Toolholder*
					h min	Y			
14D	10	4	14DER10APIRD4T+...	2 3/8" and up	1.41	8.7	Y14DER-10 APIRD	AL...-14D	
						8.8	Y14DER-10 APIRD-3+		
14D	8	3	14DER8APIRD3T+...	2 3/8" and up	1.81	8.1	Y14DER-8 APIRD	AL...-14D	

* For related holders see page 53.



API Round Casing & Tubing (con't)

External

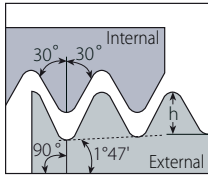

Defined by: API STD. 5B:1979
Tolerance class: Standard API RD

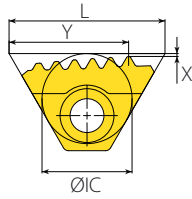

T+ Style

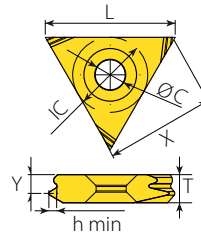

On Edge

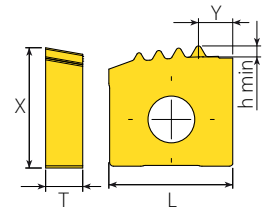

Chaser

T+ Style



Insert Size		Pitch	Teeth	Ordering Code	Dimensions mm			Anvil	
IC	L mm	TPI		RH	h min	X	Y	RH	Toolholder*
1/2" T	22	10	6	4ER10APIRD6T+...	1.41	0.2	16.2		
		8	3	4ER8APIRD3T+...	1.81	0.2	14.2	Y4T	AL..-4T
		8	5	4ER8APIRD5T+...	1.81	0.2	16.7		

* For related holders see page 54.

On Edge*



Insert Size		Pitch	Ordering Code	Dimensions mm			Position	
IC	L mm	TPI	RH	h min	T	Ø C	X	Y
1/2"	22	10	TNEC43ER10APIRD...	1.41	4.76	5.2	18.6	3.2
		8	TNEC43ER8APIRD...	1.81				

* On Edge inserts are compatible with existing holders on the market.

Chaser*



Insert Size		Pitch	Teeth	Ordering Code	Dimensions mm		Position	
L	TPI			RH	h min	T	X	Y
15.75	10	4	1616ER10APIRD4S+...		1.41	4.76	15.4	4.4
	8	3	1616ER8APIRD3S+...		1.81		15.9	

* Chaser inserts are compatible with existing holders on the market.

ТОВ «СМАРТТЕК ІНЖИНІРИНГ», Т. +380-50-396-90-96, info@smarttec.com.ua, https://www.smarttec.com.ua

API Round Casing & Tubing (con't)

Internal

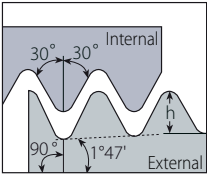

Defined by: API STD. 5B:1979
Tolerance class: Standard API RD

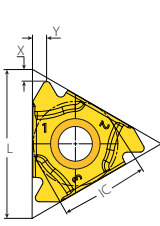

MACH TT

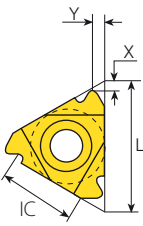

Standard

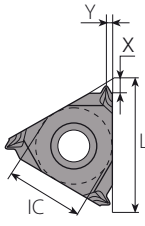

SCB Sintered
Chipbreaker



Insert Size		Pitch	Ordering Code	Dimensions mm			Anvil	
IC	L mm	TPI	RH	h min	X	Y	RH	Toolholder*
3/8"	16	10	3DTIR10APIRD...	1.41	1.1	1.3	Y13	.VRC...3DT
		8	3DTIR8APIRD...	1.81	1.1	1.5		

* For related holders see pages 57-59.

Standard



SCB

Insert Size		Pitch	Ordering Code	Dimensions mm			Anvil	
IC	L mm	TPI	RH	h min	X	Y	RH	Toolholder*
3/8"	16	10	3IR10APIRD...	1.41	1.2	1.4	YE13-APIRD Y13	AVRC... 3APIRD AVRC...-3
		8	3IR8APIRD...	1.81	1.3	1.5		
3/8" SCB	16	10	3JIR10APIRD...	1.41	1.2	1.5	Y13	AVRC...-3
		8	3JIR8APIRD...	1.81	1.3	1.5		

* For related holders see pages 48-50.

API Round Casing & Tubing (con't)

Internal

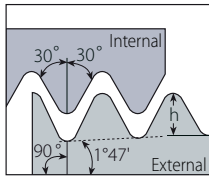

Defined by: API STD. 5B:1979
Tolerance class: Standard API RD

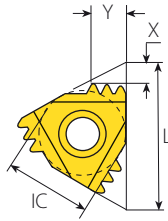

M+ Style

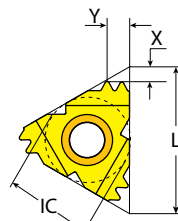

F-Line

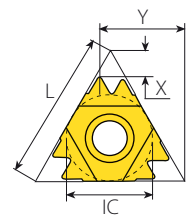

Z+ Style

M+ Style



Insert Size		Pitch	Teeth	Ordering Code	Dimensions mm			Anvil	
IC	L mm	TPI		RH	h min	X	Y	RH	Toolholder*
1/2"	22	10	2	4IR10APIRD2M+...	1.41	2.4	3.7	YI4M	AVR...-4
		8	2	4IR8APIRD2M+...	1.81	2.9	4.5		
5/8"	27	10	3	5IR10APIRD3M+...	1.41	3.9	6.3	YI5M	AVR...-5M
		8	2	5IR8APIRD2M+...	1.81	2.9	4.5		

* For related holders see pages 60-61 | page 64.

Z+ Style



Insert Size		Pitch	Teeth	Ordering Code	Dimensions mm			Anvil	
IC	L mm	TPI		RH	h min	X	Y	RH	Toolholder*
1/2"	22	10	2	4IR10APIRD2Z+...	1.41	3.0	9.9	YI4Z	AVR...-4Z
		8	2	4IR8APIRD2Z+...	1.81	3.7	9.6		

* For related holders see page 62.

F-LINE





Insert Size		Pitch	Teeth	Ordering Code	Dimensions mm			Anvil	
IC	L mm	TPI		RH	h min	X	Y	RH	Toolholder*
1/2" F	23	10	2	4FIR10APIRD2M+...	1.41	2.4	3.7	YI4M2F	AVRC...-4MF

* For related holders see page 63.

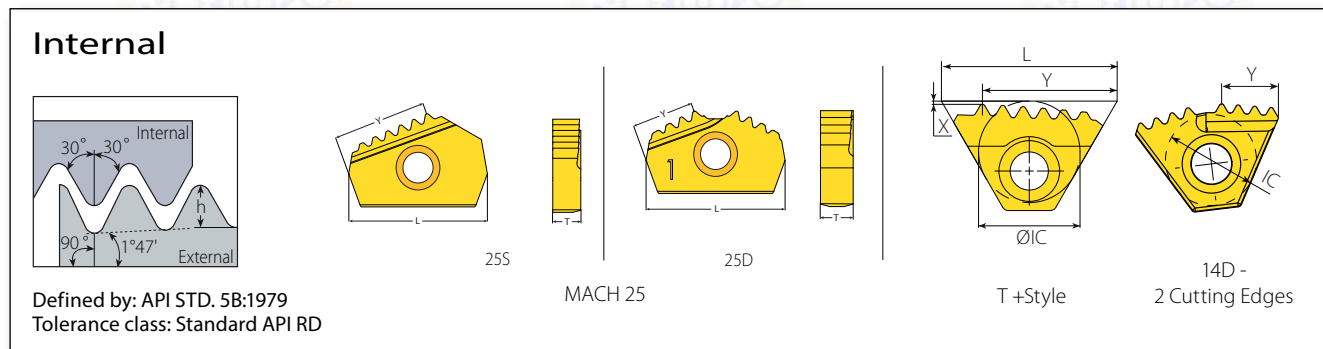
API Round Casing & Tubing (con't)



Insert Style	Insert Size	Pitch	Teeth	Ordering Code	Dimensions mm			Anvil		
					L mm	TPI	RH	h min	Y	T
	25S	25	10	6	25SIR10APIRD-6TH...	1.41	16.5	5	Y125M	AVRC..-25DT
			10	4	25SIR10APIRD-4TH...	1.41	11.0			
			8	5	25SIR8APIRD-5TH...	1.81	16.2			
			8	4	25SIR8APIRD-4TH...	1.81	13.5			

Insert Style	Insert Size	Pitch	Teeth	Ordering Code	Dimensions mm			Anvil		
					L mm	TPI	RH	h min	Y	T
	25D	25	10	4	25DIR10APIRD-4TH...	1.41	11.0	5	Y125M	AVRC..-25DT
			10	3	25DIR10APIRD-3TH...	1.41	8.5			
			8	3	25DIR8APIRD-3TH...	1.81	10.0			

* For related holders see page 64.

14D

Insert size	Pitch	Teeth	Ordering Code	Size	Dimensions mm			Anvil	
					IC	TPI	h min	Y	Toolholder*
14D	10	4	14DIR10APIRD4T+...	2 3/8" and up	1.41	8.71	Y14DIR-10 APIRD	AVRC...-14D	
14D	10	3	14DIR10APIRD3T+...	2 3/8" and up		8.79	Y14DIR-10 APIRD-3+	AVRC...-14D	
14D	8	3	14DIR8APIRD3T+...	2 3/8" and up	1.81	8.10	Y14DIR-8 APIRD	AVRC...-14D	

* For related holders see page 65.

T+ Style

Insert Size	Pitch	Teeth	Ordering Code	Dimensions mm			Anvil			
				IC	L mm	TPI	RH	Toolholder*		
	1/2" T	22	10	6	4IR10APIRD6T+...	1.43	0.2	16.8	Y4T	AVR..-4T
			8	3	4IR8APIRD3T+...	1.81	0.2	14.2		
			8	5	4IR8APIRD5T+...	1.81	0.2	16.7		

* For related holders see page 66.



API Round Casing & Tubing (con't)

Internal

Defined by: STD. 5B:1979
Tolerance class: Standard API RD

On Edge

Chaser

On Edge*



Insert Size		Pitch	Ordering Code		Dimensions mm			Position	
IC	L mm	TPI	RH		h min	T	Ø C	X	Y
1/2"	22	10	TNEC43IR10APIRD...		1.41	4.76	5.2	18.6	3.2
		8	TNEC43IR8APIRD...		1.81				

* On Edge inserts are compatible with existing holders on the market.

Chaser*



Insert Size		Pitch	Teeth	Ordering Code		Dimensions mm		Position	
L	TPI		RH		h min	T	X	Y	
15.75	10	4	1616IR10APIRD4S+...		1.41	4.76	15.4	5.7	
	8	3	1616IR8APIRD3S+...		1.81		15.9	4.4	

* Chaser inserts are compatible with existing holders on the market.

VAM

External

$a = \arctg (IPF/24)$
 Defined by: VAM
 Tolerance class: Standard VAM

MACH TT VAM F-Line On Edge



Insert Size		Pitch	Taper	Ordering Code	Size	Dimensions mm			Anvil	Toolholder*
IC	L mm	TPI	IPF	RH		h min	X	Y	RH	
1/2"	22	6	0.75	4DTER6VAM...	3 1/2"	0.97	2.1	1.9	YE4	AL..-4DT
	22	5	0.75	4DTER5VAM...	5"-9 5/8"	1.55	3.1	1.9		

* For related holders see pages 46-47.

Standard



Insert Size		Pitch	Taper	Ordering Code	Size	Dimensions mm			Anvil	Toolholder*
IC	L mm	TPI	IPF	RH		h min	X	Y	RH	
3/8"	16	8	0.75	3ER8VAM...	2 3/8", 2 7/8"	0.97	1.7	1.8	YE3	AL..-3
		6		4ER6VAM...						
1/2"	22	5	0.75	4ER5VAM...	5"-9 5/8"	1.55	2.4	2.7	YE4	AL..-4
		6		4ER6VAM...						

* For related holders see pages 48-49.

F-LINE



Insert Size		Pitch	Taper	Ordering Code	Size	Dimensions mm			Anvil	Toolholder*
IC	L mm	TPI	IPF	RH		h min	X	Y	RH	
1/2" F	23	6	0.75	4FER6VAM...	3 1/2"	0.97	2.4	2.4	YE4F	AL...-4F
		5	0.75	4FERSVAM...	5"-9 5/8"	1.54	2.4	2.7		

* For related holders see page 51.

On Edge*



Insert Size		Pitch	Taper	Ordering Code	Size	Dimensions mm			Position	
IC	L mm	TPI	IPF	RH		h min	T	Ø C	X	Y
1/2"	22	8	0.75	TNEC43ER8VAM...	2 3/8", 2 7/8"	0.97	4.76	5.2	18.6	3.3
		6		TNEC43ER6VAM...						2.9
5/8	27	5	0.75	TNEC54ERSVAM...	5"-9 5/8"	1.55	6.35	6.5	23.4	4.0

* On Edge inserts are compatible with existing holders on the market.



VAM (con't)

Internal

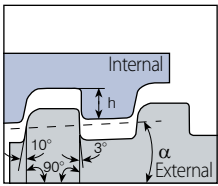

$a = \arctg (IPF/24)$

Defined by: VAM
Tolerance class: Standard VAM

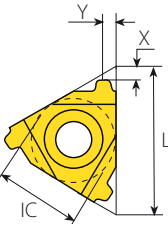

VAM

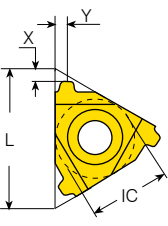

F-Line

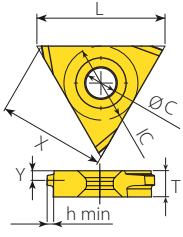

On Edge

Standard



Insert Size		Pitch	Taper	Ordering Code	Size	Dimensions mm			Anvil	
IC	L mm	TPI	IPF	RH		h min	X	Y	RH	Toolholder*
3/8"	16	8	0.75	3IR8VAM...	2 3/8", 2 7/8"	1.02	1.7	1.8	Y13	AVR...-3
1/2"	22	6		4IR6VAM.....	3 1/2"	1.02	2.5	2.5	Y14	AVR...-4
		5		4IR5VAM...	5"-9 5/8"	1.55	2.4	2.5		

* For related holders see pages 60-61.

F LINE



Insert Size		Pitch	Taper	Ordering Code	Size	Dimensions mm			Anvil	
IC	L mm	TPI	IPF	RH		h min	X	Y	RH	Toolholder*
1/2" F	23	6	0.75	4FIR6VAM...	3 1/2"	1.04	2.5	2.5	Y14F	AVRC...-4F
		5	0.75	4FIR5VAM...	5"-9 5/8"	1.54	2.4	2.5		

* For related holders see page 63.

On Edge*



Insert Size		Pitch	Taper	Ordering Code	Size	Dimensions mm			Position	
IC	L mm	TPI	IPF	RH		h min	T	Ø C	X	Y
1/2"	22	8	0.75	TNEC43IR8VAM...	2 3/8", 2 7/8"	1.02	4.76	5.2	18.6	3.2
		6		TNEC43IR6VAM...	3 1/2"	1.02	4.76			3.1
5/8"	27	5		TNEC54IR5VAM...	5"- 9 5/8"	1.55	6.35	6.5	23.4	4.2

* On Edge inserts are compatible with existing holders on the market.

New VAM

External

Defined by: VAM
Tolerance class: Standard VAM



Insert Size		Pitch	Taper	Ordering Code	Size	Dimensions mm			Anvil	
IC	L mm	TPI	IPF	RH		h min	X	Y	RH	Toolholder*
1/2"	22	6	0.75	4DTER6NVAM...	3 1/2"	0.97	2.1	1.9	YE4	AL...-4DT
		5	0.75	4DTER5NVAM...	5"-9 5/8"	1.55	3.1	2.0		

* For related holders see pages 46-47.

Laydown



Insert Size		Pitch	Taper	Ordering Code	Size	Dimensions mm			Anvil	
IC	L mm	TPI	IPF	RH		h min	X	Y	RH	Toolholder*
3/8"	16	8		3ER8NVAM...	2 3/8", 2 7/8"	0.97	1.8	1.8	YE3	AL...-3
1/2"	22	6	0.75	4ER6NVAM...	3 1/2"	0.97	2.3	2.3	YE4	AL...-4
		5		4ER5NVAM...	5"-9 5/8"	1.55	2.3	2.3		

* For related holders see pages 48-49.

F-LINE



Insert Size		Pitch	Taper	Ordering Code	Size	Dimensions mm			Anvil	
IC	L mm	TPI	IPF	RH		h min	X	Y	RH	Toolholder*
1/2" F	23	6	0.75	4FER6NVAM...	3 1/2"	0.97	2.2	2.1	YE4F	AL...-4F
		5	0.75	4FER5NVAM...	5"-9 5/8"	1.55	2.5	2.3		

* For related holders see page 51.



NEW VAM (con't)

Internal

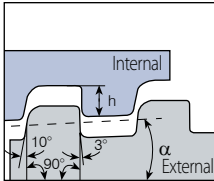

$\alpha = \arctg (IPF/24)$

Defined by: VAM
Tolerance class: Standard VAM

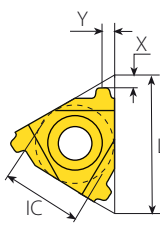

Standard

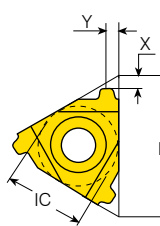

F-Line

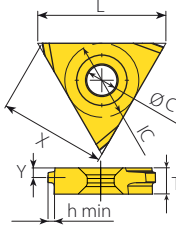

On Edge

Laydown



Insert Size		Pitch	Taper	Ordering Code	Size	Dimensions mm			Anvil	
IC	L mm	TPI	IPF	RH		h min	X	Y	RH	Toolholder*
3/8"	16	8		3IR8NVAM...	2 3/8" , 2 7/8"	1.23	1.8	1.8	Y13	AVR...-3
1/2"	22	6	0.75	4IR6NVAM...	3 1/2"	1.23	2.5	2.5	Y14	AVR...-4
		5		4IR5NVAM...	5"-9 5/8"	1.77	2.3	2.5		

* For related holders see pages 60-61.

F LINE



Insert Size		Pitch	Taper	Ordering Code	Size	Dimensions mm			Anvil	
IC	L mm	TPI	IPF	RH		h min	X	Y	RH	Toolholder*
1/2" F	23	6	0.75	4FIR6NVAM...	3 1/2"	1.23	2.0	1.8	Y14F	AVRC...-4F
		5	0.75	4FIR5NVAM...	5"-9 5/8"	1.76	2.1	2.1		

* For related holders see page 53.

On Edge*



Insert Size		Pitch	Taper	Ordering Code	Size	Dimensions mm				
IC	L mm	TPI	IPF	RH		h min	T	Ø C	X	Y
1/2"	22	8		TNEC43IR8NVAM...	2 3/8" - 2 7/8"	1.23	4.76	5.2	18.6	3.2
		6	0.75	TNEC43IR6NVAM...	3 1/2" - 4 1/2"	1.23	4.76	5.2		3.1
5/8"	27	5		TNEC54IR5NVAM...	5" - 16"	1.77	6.35	6.5	23.4	4.2

* On Edge inserts are compatible with existing holders on the market.

EL-Extreme Line

External

$\alpha = \arctg (IPF/24)$

Defined by: API STD,5B:1979
Tolerance class: Standard

MACH TT Standard - External On Edge - External



Insert Size		Pitch	Taper	Ordering Code	Size	Dimensions mm			Anvil	Toolholder*
IC	L mm	TPI	IPF	RH		h min	X	Y	RH	
1/2"	22	6	1.5	4DTER6EL15...	5"-7 5/8"	1.21	2.1	1.9	YE4	AL..-4DT
		5	1.25	4DTER5EL125...	8 5/8"-10 3/4"	1.71	2.1	2.3		

* For related holders see pages 46-47.

Standard



Insert Size		Pitch	Taper	Ordering Code	Size	Dimensions mm			Anvil	Toolholder*
IC	L mm	TPI	IPF	RH		h min	X	Y	RH	
1/2"	22	6	1.5	4ER6EL15...	5"-7 5/8"	1.21	1.9	1.9	YE4	AL..-4
		5	1.25	4ER5EL125...	8 5/8"-10 3/4"	1.71	2.3	2.4		

* For related holders see pages 48-49.

On Edge*



Insert Size		Pitch	Taper	Ordering Code	Size	Dimensions mm			Position	
IC	L mm	TPI	IPF	RH		h min	T	Ø C	X	Y
5/8"	27	6	1.5	TNEC54ER6E15...	5"-7 5/8"	1.21	6.35	6.5	23.4	4.8
		5	1.25	TNEC54ER5E125...	8 5/8"-10 3/4"	1.71	6.35			4.3

* On Edge inserts are compatible with existing holders on the market.



EL-Extreme Line

Internal

$\alpha = \arctg (IPF/24)$

Defined by: API STD,5B:1979
Tolerance class: Standard

Standard - Internal

On Edge - Internal

Standard



Insert Size		Pitch	Taper	Ordering Code	Size	Dimensions mm			Anvil	Toolholder*
IC	L mm	TPI	IPF	RH		h min	X	Y	RH	
1/2"	22	6	1.5	4IR6EL15...	5"-7 5/8"	1.39	1.8	1.9	Y14	AVR.-4
		5	1.25	4IR5EL125...	8 5/8"-10 3/4"	1.91	2.2	2.4		

* For related holders see pages 60-61.

On Edge*



Insert Size		Pitch	Taper	Ordering Code	Size	Dimensions mm			Position	
IC	L mm	TPI	IPF	RH		h min	T	Ø C	X	Y
5/8"	27	6	1.5	TNEC54IR6EL15...	5"-7 5/8"	1.39	6.35	6.5	23.4	4.8
		5	1.25	TNEC54IR5EL125...	8 5/8"-10 3/4"	1.91	6.35			4.3

* On Edge inserts are compatible with existing holders on the market.

Hughes H-90

External/Internal

$\alpha = \arctg (IPF/24)$

Defined by: API SPEC.7-2
Tolerance class: Standard

U Style On Edge - External On Edge - Internal

U Style - External



Insert Size		Pitch	Taper	Ordering Code	Size	Dimensions mm			Anvil	
IC	L mm	TPI	IPF	RH		h min	X	Y	RH	Toolholder*
1/2" U	22	3.5	2	4UER3.5H902...	3 1/2" - 6 5/8"	2.50	4.2	11	YE4U-H90	AL...-4U
		3.5	3	4UER3.5H903...	7" - 8 5/8"	2.50	4.2	11		
5/8" U	27	3	1.25**	5UER3H90SL...	2 3/8" - 3 1/2"	2.24	5.5	13.7	YE5U-H90	AL...-5UH90

* For related holders see page 55.

** H-90 Slimline

On Edge* - External



Insert Size		Pitch	Taper	Ordering Code	Size	Dimensions mm			Position	
IC	L mm	TPI	IPF	RH		h min	T	Ø C	X	Y
5/8"	27	3 1/2	2	TNEC55ER3.5H902...	3 1/2" - 6 5/8"	2.50	7.93	6.5	23.4	4.3
		3 1/2	3	TNEC55ER3.5H903...	7" - 8 5/8"	2.50	7.93			
		3	1 1/4	TNEC56ER3H90SL...	2 3/8" - 3 1/2"	2.24	9.53			

* On Edge inserts are compatible with existing holders on the market.

U Style - Internal



Insert Size		Pitch	Taper	Ordering Code	Size	Dimensions mm			Anvil	
IC	L mm	TPI	IPF	RH		h min	X	Y	RH	Toolholder*
1/2" U	22	3.5	2	4UIR3.5H902...	3 1/2" - 6 5/8"	2.50	4.2	11	YI4U-H90	AVR...-4U
		3.5	3	4UIR3.5H903...	7" - 8 5/8"	2.50	4.2	11		
5/8" U	27	3	1.25**	5UIR3H90SL...	2 3/8" - 3 1/2"	2.24	5.5	13.7	YI5U-H90	AVR...-5UH90

* For related holders see page 67.

** H-90 Slimline

On Edge* - Internal



Insert Size		Pitch	Taper	Ordering Code	Size	Dimensions mm			Position	
IC	L mm	TPI	IPF	RH		h min	T	Ø C	X	Y
5/8"	27	3 1/2	2	TNEC55IR3.5H902...	3 1/2" - 6 5/8"	2.49	7.93	6.5	23.4	4.3
		3 1/2	3	TNEC55IR3.5H903...	7" - 8 5/8"	2.49	7.93			
		3	1 1/4	TNEC56IR3H90SL...	2 3/8" - 3 1/2"	2.24	9.53			

* On Edge inserts are compatible with existing holders on the market.

GOST (OTTM / OTTG)

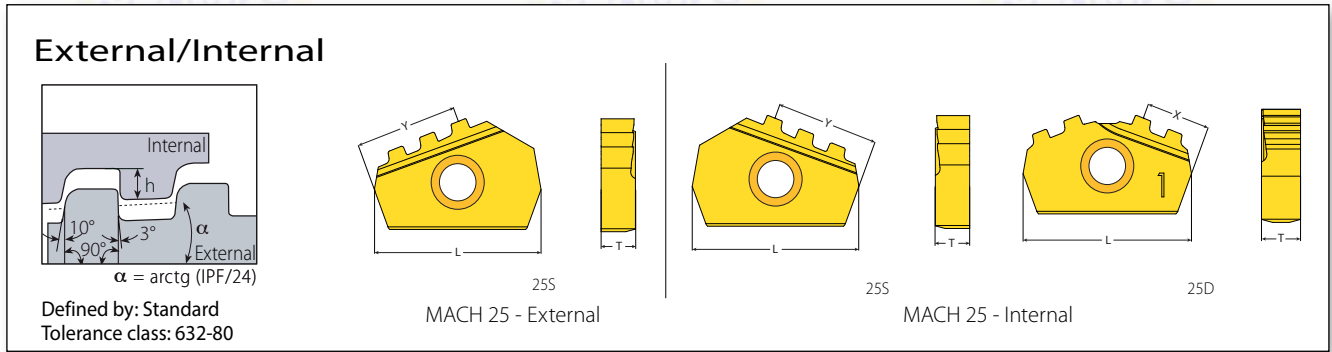

MACH 25 - External



Insert Style	Insert Size	Pitch	Teeth	Ordering Code	Dimensions mm			Anvil		
					L mm	TPI	IPF	RH	h min	Y
25S	25	5	3	0.75	25SER5OTTM-3TH...	1.6	15.7	5	YE25M	ALC..-25DT

* For related holders see page 52.

MACH 25 - Internal



Insert Style	Insert Size	Pitch	Teeth	Ordering Code	Dimensions mm			Anvil		
					L mm	TPI	IPF	RH	h min	Y
25S	25	5	0.75	3	25SIR5OTTM-3TH...	1.6	14.3	5	YI25M	ALC..-25DT



Insert Style	Insert Size	Pitch	Teeth	Ordering Code	Dimensions mm			Anvil		
					L mm	TPI	IPF	RH	h min	Y
25D	25	5	0.75	2	25DIR5OTTM-2TH...	1.6	9.5	5	YI25M	ALC..-25DT

* For related holders see page 64.

External Toolholders

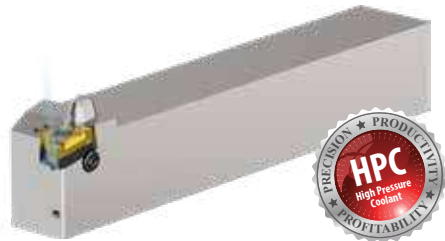
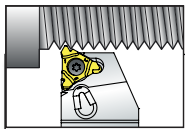

Max. 70 bar

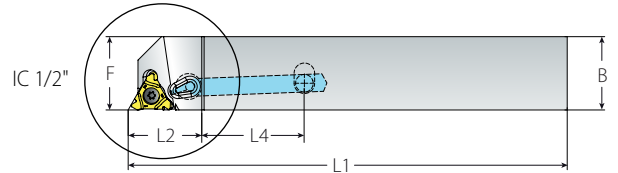
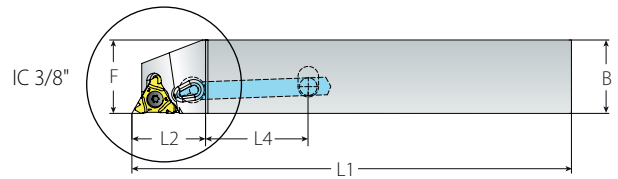

MACH TT with Coolant (HPC) - 2 Inlets

Spare Parts

Insert Size	Ordering Code	Dimensions mm										
IC	RH	H=H1=B	F	L1	L2	L4	Insert Screw	Anvil Screw	Torx Key	Anvil RH	Plug Screw	Socket Screw
3/8"	ALC16-3DT	16	16	100			SA3T (2.0Nm)	SY3T	K3T	YE3	Flush Plug G1/8"	Socket Screw M6x5
	ALC20-3DT	20	20	125								
	ALC25-3DT	25	25	150	25.4							
	ALC32-3DT	32	32	170								
1/2"	ALC25-4DT	25	25	150			SA4T (3.0 Nm)	SY4T	K4T	YE4	Flush Plug G1/8"	Socket Screw M6x5
	ALC32-4DT	32	32	170	27.5							
	ALC40-4DT	40	40	206								

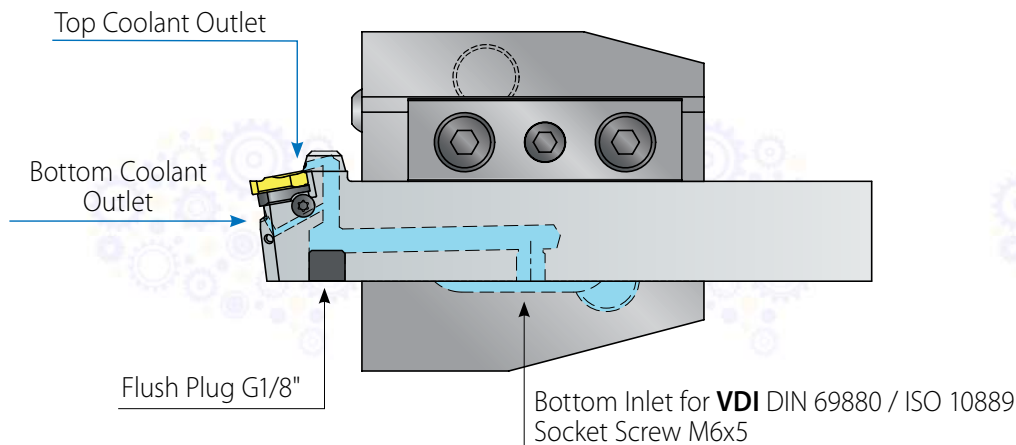

When reassembling the M6X5 plug, it is necessary to use LOCTITE 542.

The following HPC accessories (not included) can be ordered separately:

Image	Ordering Code	Item Number
	Tube Connector 25-6	013-00941
	Angled Fitting G1_8x6	013-00947
	Straight Fitting G1_8x6	013-00942

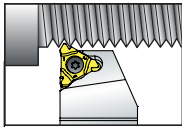

External Toolholders

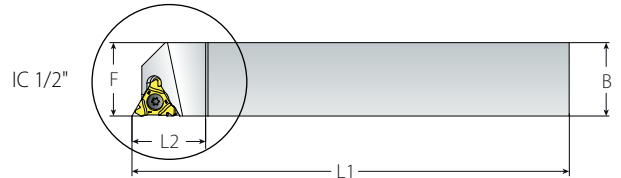
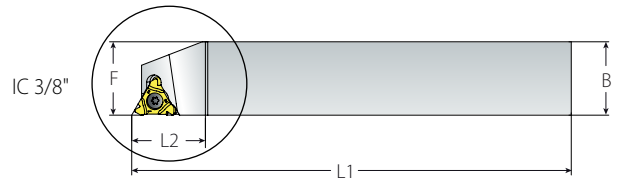
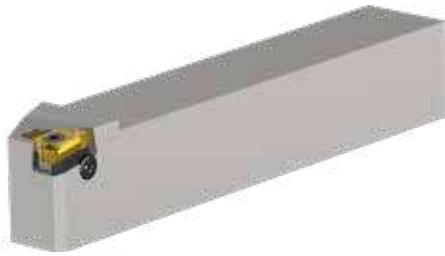

MACH TT

Insert Size	Ordering Code	Dimensions mm			
IC	RH	H=H1=B	F	L1	L2
3/8"	AL12-3DT	12	16	85	20.7
	AL16-3DT	16	16	100	22.0
	AL20-3DT	20	20	127	24.5
	AL25-3DT	25	25	150	25.8
	AL32-3DT	32	32	170	29.5
1/2"	AL25-4DT	25	25	150	27.5
	AL32-4DT	32	32	168	27.5
	AL40-4DT	40	40	198	27.5

Spare Parts

Insert Screw	Anvil Screw	Torx Key	Anvil RH
SA3T (2.0 Nm)	SY3T	K3T	YE3
SA4T (3.0Nm)	SY4T	K4T	YE4

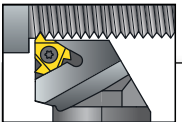

External Toolholders



Max. 70 bar

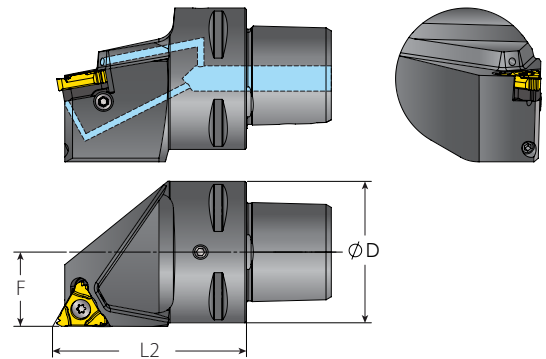

MACH TT V-CAP with Coolant (HPC)

Insert Size	Ordering Code	Dimensions mm		
IC	RH	D	F	L2
3/8"	VCAP32-SER17047-3DT	32	17	47
	VCAP40-SER21055-3DT	40	21	55
	VCAP50-SER26065-3DT	50	26	65
	VCAP63-SER33075-3DT	63	33	75
1/2"	VCAP40-SER21055-4DT	40	21	55
	VCAP50-SER26065-4DT	50	26	65
	VCAP63-SER33075-4DT	63	33	75
	VCAP80-SER42080-4DT	80	42	80

Spare Parts

Insert Screw	Anvil Screw	Torx Key	Anvil RH
SA3T (2.0 Nm)	SY3T	K3T	YE3
SA4T (3.0Nm)	SY4T	K4T	YE4

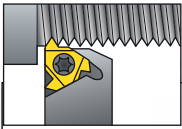

External Toolholders

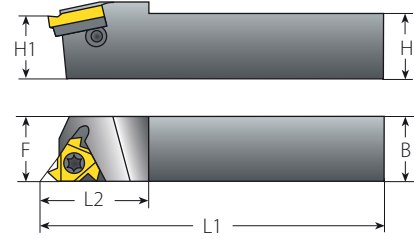
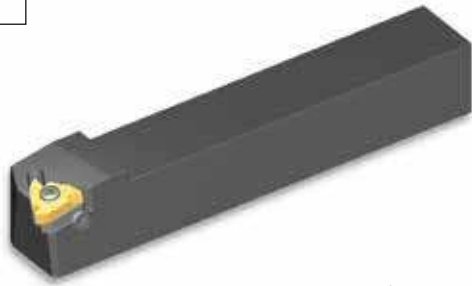

The AL...-3 holders are supplied with standard anvil (see spare parts table below).

Standard

Insert Size	Ordering Code	Dimensions mm			
IC	RH/LH	H=H1=B	F	L1	L2
3/8"	NL12-3	12	16	83.2	22
	AL3/8-3	9.52	16	63.6	20.5
	AL12-3	12	16	83.2	22
	AL16-3	16	16	100.0	20.5
	AL20-3	20	20	128.6	30
	AL25-3	25	25	153.6	30
1/2"	AL25-4	25	25	155.7	36
	AL32-4	32	32	175.7	36
	AL40-4	40	40	205.7	36
5/8"	AL25-5	25	32	151.6	35
	AL32-5	32	32	176.6	40
	AL40-5	40	40	206.6	40
	AL50-5	50	50	256.6	40

Spare Parts

Insert Screw	Anvil Screw	Torx Key	Anvil RH	Anvil LH
SA3T	-	K3T	-	-
SA3T	SY3T	K3T	YE3	YI3
SA4T	SY4T	K4T	YE4	YI4
SA5T	SY5T	K5T	YE5	YI5

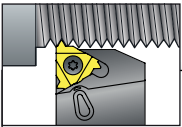

External Toolholders

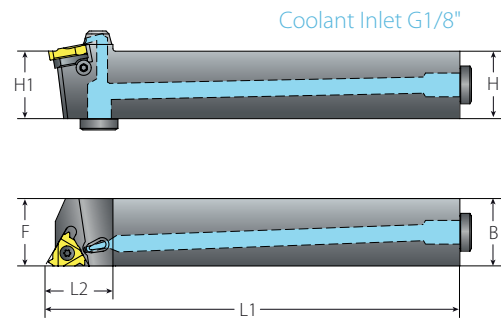

Standard with Coolant

Insert Size	Ordering Code	Dimensions mm			
IC	RH	H=H1=B	F	L1	L2
3/8"	ALC16-3	16	16	100	24.5
	ALC20-3	20	20	129	30.0
	ALC25-3	25	25	154	30.0
	ALC32-3	32	32	174	30.0

Spare Parts

Insert Screw	Anvil Screw	Torx Key	Anvil RH	Plug Screw
SA3T	SY3T	K3T	YE3	Plug G1/8"

The above toolholders are for RH inserts. For LH inserts, add LH to the toolholder's ordering code. (Example AL20-3 LH).

The above toolholders have a 1.5° helix angle. For other helix angles, see page 72.

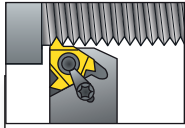

External Toolholders

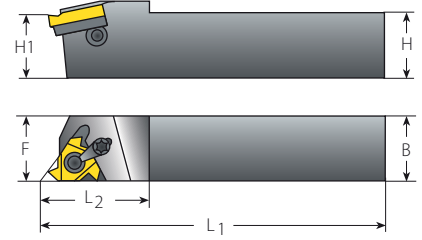
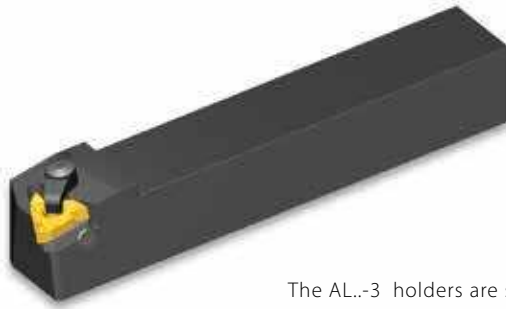

The AL..-3 holders are supplied with standard anvil (see spare parts table below).

Standard with Clamp (Dual System, Screw or Clamp)

Standard with Clamp (Dual System, Screw or Clamp)						Spare Parts					
Insert Size	Ordering Code	Dimensions mm									
IC	RH/LH	H=H1=B	F	L1	L2	Insert Screw	Anvil Screw	Clamp	Torx Key	Anvil RH	Anvil LH
3/8"	AL16-3C	16	16	100.0	20.5	SA3T	SY3T	C3	K3CT	YE3	YI3
	AL20-3C	20	20	128.6	30						
	AL25-3C	25	25	153.6	30						
	AL32-3C	32	32	173.6	30						
1/2"	AL25-4C	25	25	155.7	36	SA4T	SY4T	C4	K4T	YE4	YI4
	AL32-4C	32	32	175.7	36						
	AL40-4C	40	40	205.7	36						
5/8"	AL25-5C	25	32	151.6	35	SA5T	SY5T	C5	K5T	YE5	YI5
	AL32-5C	32	32	176.6	40						
	AL40-5C	40	40	206.6	40						
AL50-5C	50	50	256.6	40							

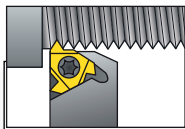

External Toolholders

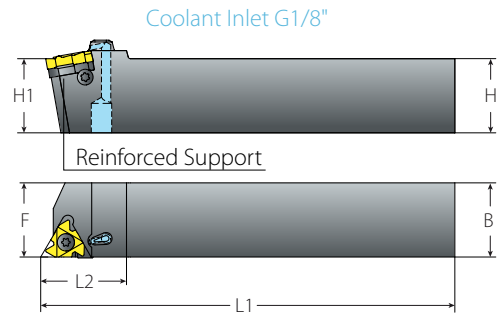

API with Coolant

API with Coolant						Spare Parts			
Insert Size	Ordering Code	Dimensions mm							
IC	RH	H=H1=B	F	L1	L2	Insert Screw	Anvil Screw	Torx Key	Anvil RH
1/2"	ALC32-4-5BUT/API	32	32	177	37	SA4T	SY4T	K4T	YEI4-API-1P
	ALC40-4-5BUT/API	40	40	205	37				YEI4-5BUT

The above toolholders are for RH inserts. For LH inserts, add LH to the toolholder's ordering code (Example AL32-4Z LH).

The above toolholders have a 1.5° helix angle. For other helix angles, see page 72.



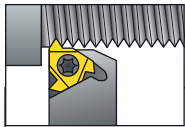

External Toolholders

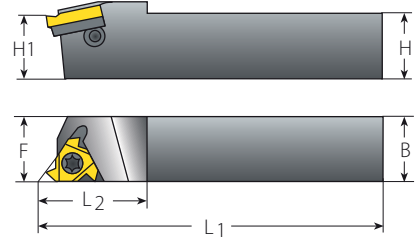

Oil & Gas

Insert Size	Ordering Code	Thread Form	Connection no. or size	Dimensions mm			Helix Angle	Spare Parts					
				H=H1=B=F	L1	L2		Insert Screw	Anvil Screw	Torx Key	Anvil RH	Anvil LH	
3/8"	AL32-3-APIRD	APIRD 8	2.375"-20"	32	173	28.8	1	SA3T	SY3T	K3T	YEI3 APIRD		
	AL40-3-APIRD	APIRD 10	1.05"-3.5"	40	205	37.4	1						
1/2"	AL32-4-5BUT/API	5BUT, V0.038R, V0.050, V0.040, V0.055	4 1/2"-20"	32	177	36.6	0	SA4T	SY4T	K4T	YEI4-API-1P		
	AL40-4-5BUT/API		NC10-NC77 all sizes	40	204	34.5	0				YEI4-5BUT		
5/8"	AL32-5OIL	V0.038R, V0.050	NC23-NC77 all sizes	32	175.9	40	1.5	SA5T	SY5T	K5T	YE5OIL	YI5OIL	
	AL40-5OIL			40	205.9	40	1.5						

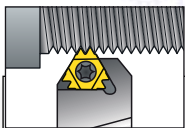

External Toolholders

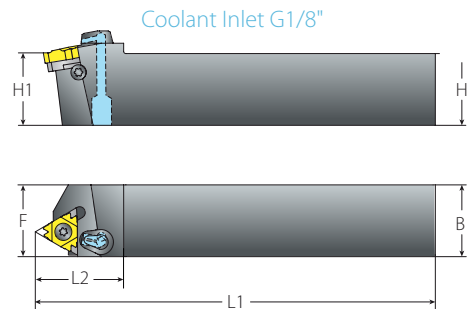

Z+ Style with Coolant

Insert Size	Ordering Code	Dimensions mm				Spare Parts			
		H=H1=B	F	L1	L2	Insert Screw	Anvil Screw	Torx Key	Anvil RH
1/2"Z	ALC32-4Z	32	32	178	37	SA4T	SY4T	K4T	YE4Z
	ALC40-4Z	40	40	208	37				

The above toolholders are for RH inserts. For LH inserts, add LH to the toolholder's ordering code. (Example AL32-4Z LH).

All Z+ Style toolholders have a 1.5° helix angle.

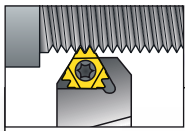

External Toolholders

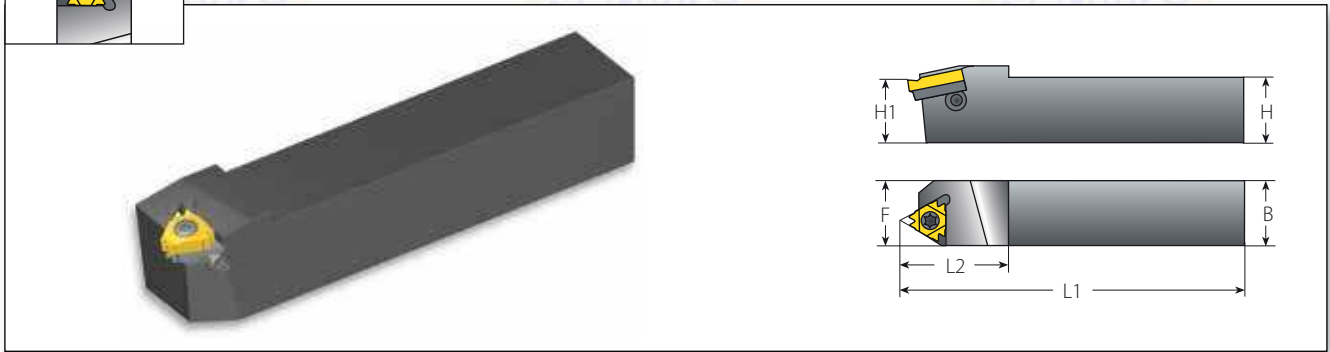

Z+ Style

Insert Size	Ordering Code	Dimensions (mm)			
		H=H1=B	F	L1	L2
1/2"Z	AL32-4Z	32	32	178.4	38
	AL40-4Z	40	40	208.4	38

Spare Parts



Insert Screw	Anvil Screw	Torx Key	Anvil RH	Anvil LH
SA4T	SY4T	K4T	YE4Z	YI4Z

All Z+ Style toolholders have a 1.5° helix angle.

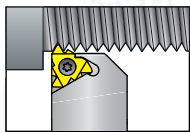

External Toolholders

FLINE

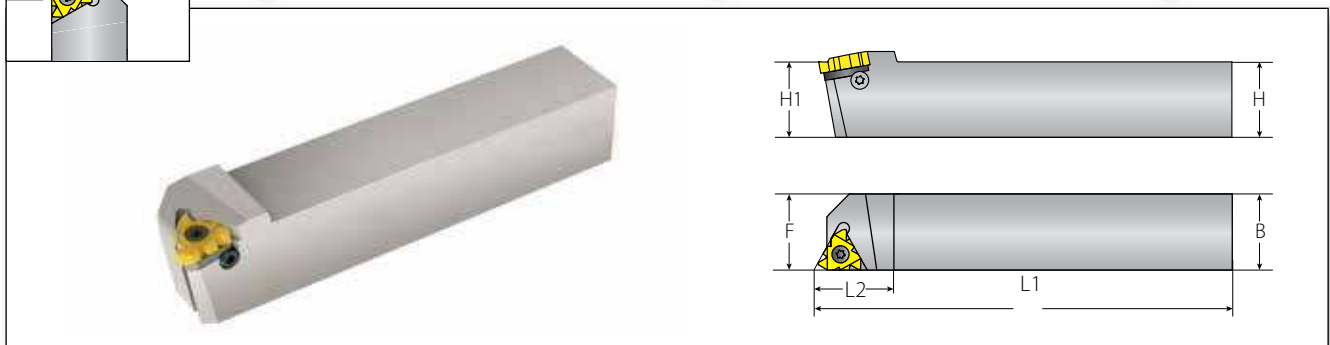

F-Line Standard

Insert Size	Ordering Code	Dimensions mm			
		H=H1=B	F	L1	L2
1/2" F	AL25-4F	25	25	155	33
	AL32-4F	32	32	175	33
	AL40-4F	40	40	205	33

Spare Parts



Insert Screw	Anvil Screw	Torx Key	Anvil RH
SA4T	SY4T	K4T	YE4F

The above toolholders are for RH inserts. For LH inserts, add LH to the toolholder's ordering code (Example AL32-4Z LH).

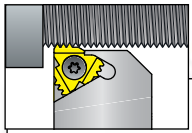

External Toolholders

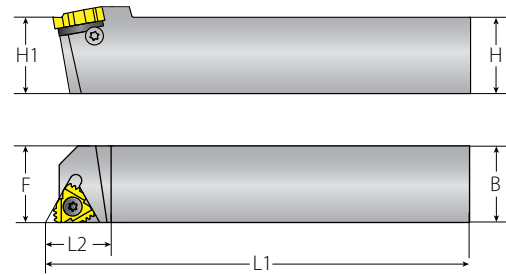

F-Line Multi+ Style

Insert Size	Ordering Code	Dimensions mm				
		IC	RH	H=H1=B	F	L1
1/2" F	AL32-4MF	32	32	175	33	
	AL40-4MF	40	40	205	33	

Spare Parts

Insert Screw	Anvil Screw	Torx Key	Anvil RH
SA4T	SY4T	K4T	YE4M2F

The above toolholders are for RH inserts. For LH inserts, add LH to the toolholder's ordering code (Example AL32-4MF LH).

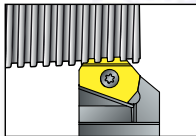

External Toolholders

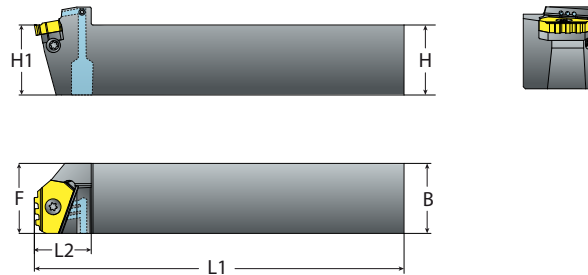

MACH 25 with Coolant

Insert Size	Ordering Code	Dimensions mm			
		RH	H=H1=B	F	L1
25	ALC25-25DT	25	30	150	
	ALC32-25DT	32	32	170	26
	ALC40-25DT	40	40	200	

Spare Parts

Insert Screw	Anvil Screw	Torx Key	Anvil RH
SA4T	SY25TW	K6T	YE25M

All MACH 25 Style toolholders have a 0° helix angle.



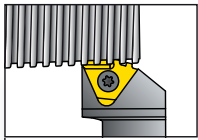

14D External Toolholders

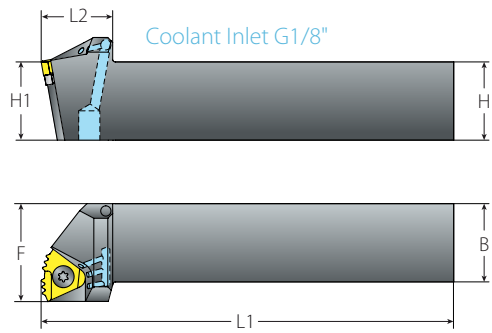
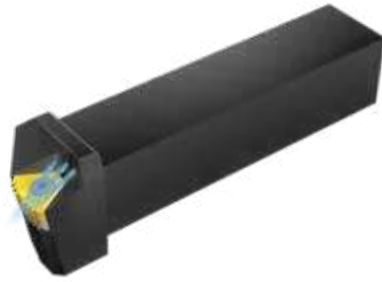

14D Standard with Coolant

Insert Size	Ordering Code	Dimensions mm			
IC	RH	H=H1=B	F	L1	L2
14D	ALC32-14D	32	32	170	30
	ALC40-14D	40	40	200	30

Spare Parts



Insert Screw	Anvil Screw & Washer	Torx Key	Anvil Key
SA5T	M4X6(14D)	K5T	KT15

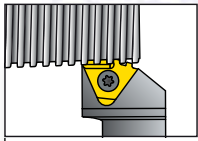

14D External Toolholders

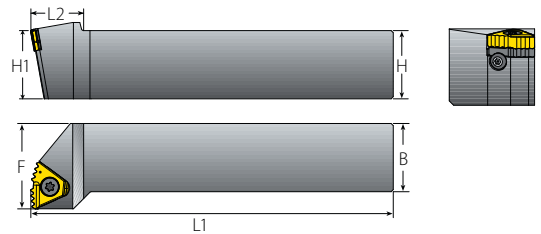

14D Standard

Insert Size	Ordering Code	Dimensions mm			
IC	RH	H=H1=B	F	L1	L2
14D	AL25-14D	25	32	150	25
	AL32-14D	32	40	170	25
	AL40-14D	40	40	200	30

Spare Parts



Insert Screw	Anvil Screw & Washer	Torx Key	Anvil Key
SA5T	M4x6(14D)	K5T	KT15

14D holders are supplied without anvils.
For specific applications, please use the anvils indicated in the table on page 73.

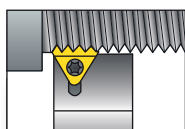

External Toolholders

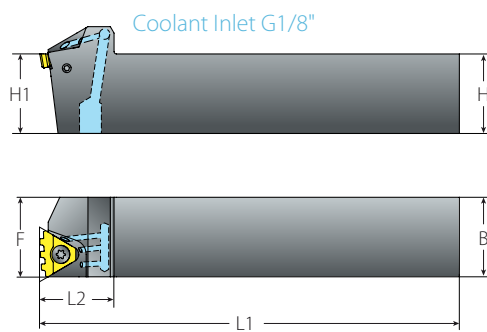

T+ Style with Coolant

Insert Size	Ordering Code	Dimensions mm			
IC	RH	H=H1=B	F	L1	L2
1/2" T	ALC32-4T	32	32	170	30
	ALC40-4T	40	40	200	30

Spare Parts

Insert Screw	Anvil Screw	Torx Key	Anvil Key	Anvil RH
SA4T	SY4K2	K4T	K2	Y4T

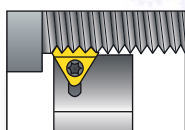

External Toolholders

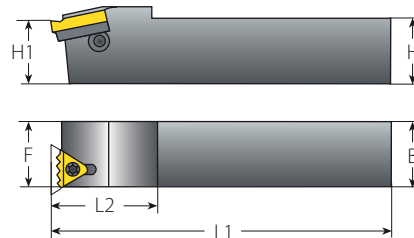
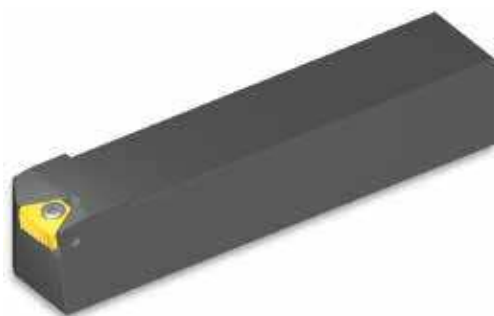

T+ Style

Insert Size	Ordering Code	Dimensions mm			
IC	RH	H=H1=B	F	L1	L2
1/2" T	AL25-4T	25	27	150	30
	AL32-4T	32	34	170	30
	AL40-4T	40	42	200	30

Spare Parts

Insert Screw	Anvil Screw	Torx Key	Anvil Key	Anvil RH/LH
SA4T	SY4K2	K4T	K2	Y4T

All T+ Style toolholders have a 0° helix angle.

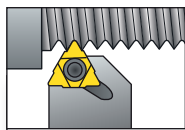

External Toolholders

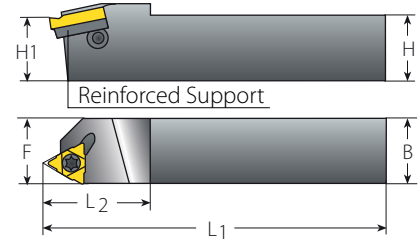

U Style

Insert Size	Ordering Code	Dimensions mm				Spare Parts				
		IC	RH/LH	H=H1=B	F	L1	L2	Insert Screw	Anvil Screw	Torx Key
1/2"U	AL25-4U	25	25	178.4	38	SA4T	SY4T	K4T	YE4U	YI4U
	AL32-4U	32	32	178.4	38					
	AL40-4U	40	40	208.4	38					
5/8"U	AL25-5U	25	25	179.1	40	SA5T	SY5T	K5T	YE5U	YI5U
	AL32-5U	32	32	179.1	40					
	AL40-5U	40	40	209.1	40					
	AL50-5U	50	50	259.1	40					

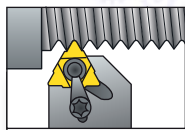

External Toolholders

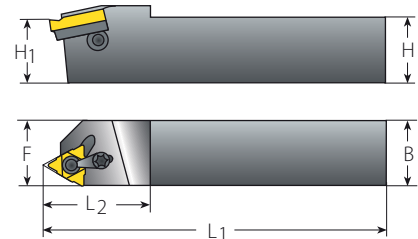

U Style with Clamp

(Dual System, Screw or Clamp)

Insert Size	Ordering Code	Dimensions mm				Spare Parts					
		IC	RH/LH	H=H1=B	F	L1	L2	Insert Screw	Anvil Screw	Clamp	Torx Key
1/2"U	AL32-4UC	32	32	178.4	38	SA4T	SY4T	C4	K4T	YE4U	YI4U
	AL40-4UC	40	40	208.4	38						
5/8"U	AL32-5UC	32	32	179.1	40	SA5T	SY5T	C5	K5T	YE5U	YI5U
	AL40-5UC	40	40	209.1	40						
	AL50-5UC	50	50	259.1	40						

The above toolholders are for RH inserts. For LH inserts, add LH to the toolholder's ordering code. (Example AL25-4U LH)

All U Style Toolholders have a 1.5° helix angle. For other helix angles see page 72.



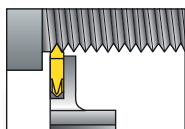

External Toolholders

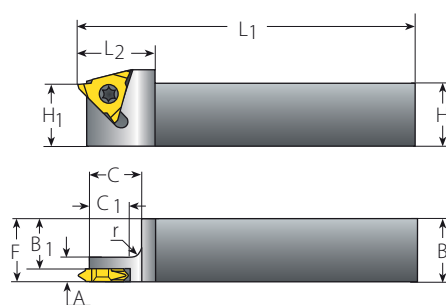
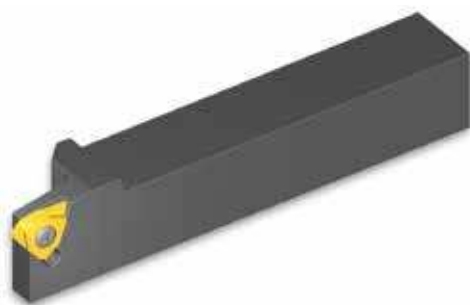

Slim Throat

Insert Size		Ordering Code		Dimensions mm							Spare Parts	
IC	RH/LH	H=B=F	H1	A	B1	C	C1	L1	L2	r	Insert Screw	Torx Key
1/4"V	NL8-2V	8	10	7	4.8	12.5	11.5	60	14.0	1	SN2T	K2T
	NL10-2V	10	10	7	6.8	12.5	11.5	70	14.0	1		
	NL12-2V	12	12	7	8.8	14.5	11.5	80	14.0	3		
	NL16-2V	16	16	7	12.8	14.5	11.5	100	14.0	3		
3/8"V	NL10-3V	10	14	7	6.4	14.5	11.5	70	18.5	3	SN3TV	K3T
	NL12-3V	12	14	7	8.4	14.5	11.5	80	18.5	3		
	NL16-3V	16	16	7	12.4	14.5	11.5	100	25.0	3		
	NL20-3V	20	20	7	16.4	16.5	11.5	125	30.0	3		
	NL25-3V	25	25	7	21.4	16.5	11.5	150	30.0	5		
	NL32-3V	32	32	7	28.4	16.5	11.5	170	30.0	5		
	NL40-3V	40	40	7	36.4	16.5	11.5	200	30.0	5		
1/2"V	NL25-4V	25	25	12	20.2	16.5	11.5	150	30.0	5	SN4T	K4T
	NL32-4V	32	32	12	27.2	16.5	11.5	170	30.0	5		
	NL40-4V	40	40	12	35.2	16.5	11.5	200	30.0	5		

All Slim Throat toolholders have a 1.5° helix angle.

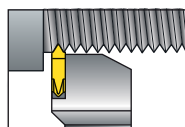

External Toolholders

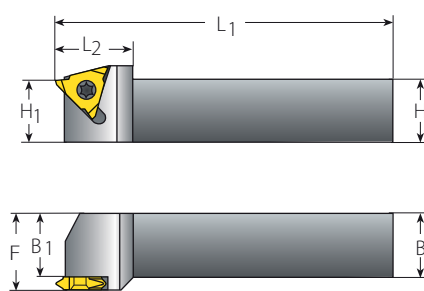

V Style

Insert Size		Ordering Code		Dimensions mm				Spare Parts	
IC	RH	H=H1=B	B1	F	L1	L2	Insert Screw	Torx key	
5/8"V	NL32-5V-6	32	25.5	32.0	170	40	SN6T	K6T	
	NL32-5V-8	32	25.5	34.1	170	40			
	NL32-5V-10	32	25.5	35.8	170	40			
	NL40-5V-6	40	33.5	40.0	200	40			
	NL40-5V-8	40	33.5	42.1	200	40			
	NL40-5V-10	40	33.5	43.8	200	40			

All V Style toolholders have a 1° helix angle.

The above toolholders are for RH inserts. For LH inserts, add LH to the toolholder's ordering code. (Example NL32-5V-6 LH)

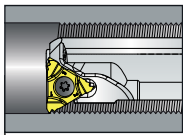

Internal Toolholders

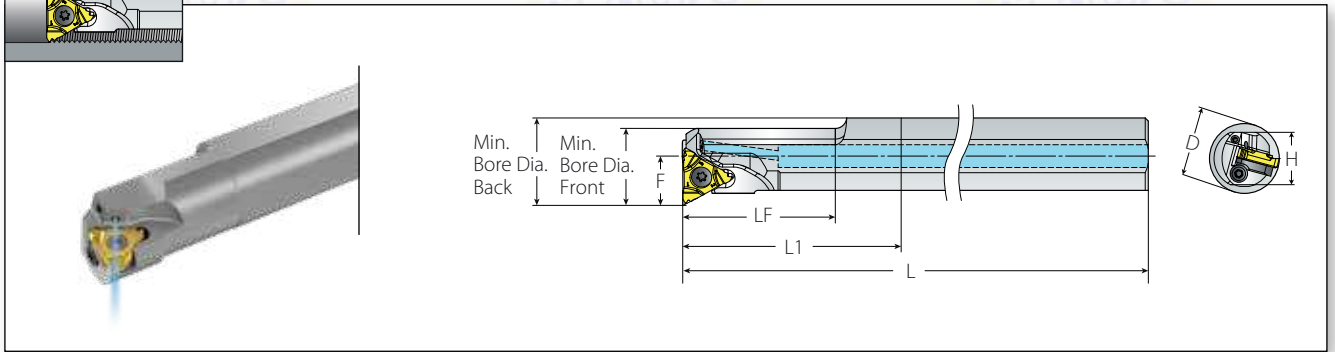

MACH TT with Coolant

Insert Size		Ordering Code		Dimensions mm						Spare Parts			
IC	RH	H	L	LF	L1	D	F	Minimum Bore Ø Front	Minimum Bore Ø Back	Insert Screw	Anvil Screw	Insert Key	Anvil
3/8"	NVRC-1617-3DT	15	150	27	48	16	11.7	17	20.0	SN3T	-	-	-
	NVRC-2020-3DT	18	180	40	60	20	13.7	20	24.1	-	-	-	-
	AVRC-2022-3DT	18	180	40	60	20	13.7	22	24.0	SA3T	SY3T	-	Y13
	NVRC-2022-3DT	18	180	40	60	20	13.7	22	24.0	SN3T	-	K3T	-
	AVRC-2526-3DT	23	200	40	75	25	16.1	26	29.0	-	-	-	-
	AVRC-3229-3DT	29	250	40	96	32	19.7	29	36.5	-	-	-	-
	AVRC-3236-3DT	29	250	40	96	32	19.7	36	36.0	SA3T	SY3T	-	Y13
	AVRC-4037-3DT	36	300	40	120	40	23.6	37	44.0	-	-	-	-

All insert screws max. torque 2.0 Nm.

New Ordering Code System for MACH TT Internal Holders

The numbers in the ordering code represent the shank diameter (D) and Minimum Bore Ø Front.

Minimum Bore Ø Front = 22 mm

For example: AVRC - 20 22 -3DT

D = 20 mm

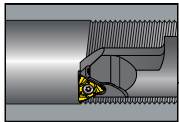

Internal Toolholders

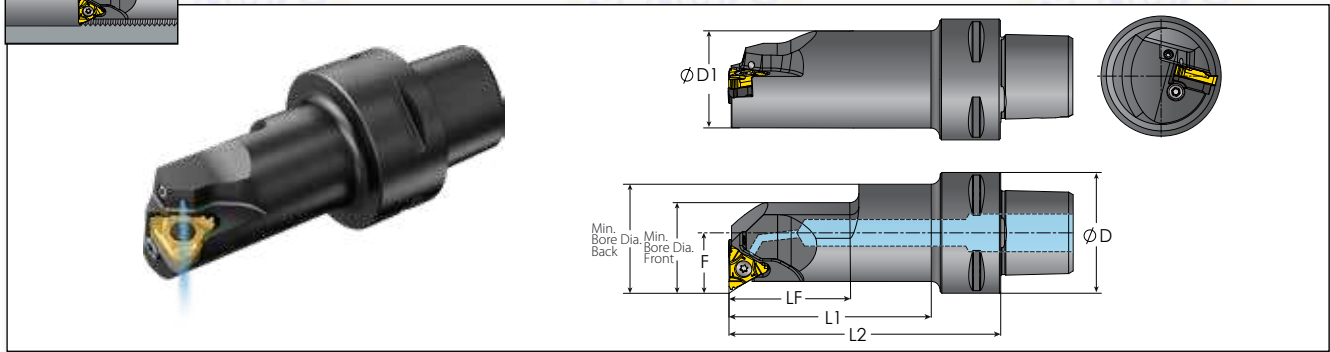

MACH TT V-CAP with Coolant (HPC)

Insert Size	Ordering Code	Dimensions mm								Spare Parts					
		IC	RH	D	D1	F	L2	LF	L1	Minimum Bore Ø Front	Minimum Bore Ø Back	Insert Screw	Anvil Screw	Insert Key	Anvil
3/8"	VCAP32-SIR12055-3DT			32	16.2	12	55	27	37	18.5	20.5	SN3T	-	-	-
	VCAP40-SIR10060-3DT			40	12.9	10.3	60	27	37	-	17.0	SN3TM	-	-	-
	VCAP40-SIR12060-3DT				16.2	12	60	27	37	18.5	20.5	SN3T	-	-	-
	VCAP40-SIR14060-3DT			20.6	14	60	27	37	23	25.0	SA3T	SY3T	K3T	Y13	
	VCAP40-SIR17070-3DT			26.2	17	70	32	47	27.5	31.0					
	VCAP40-SIR20090-3DT			32.2	20	90	40	67	33	36.5					
	VCAP40-SIR24080-3DT			40.2	24	80	45	60	40	44.5	SA3T	SY3T	K3T	Y13	
	VCAP50-SIR12060-3DT			50	16.2	12	60	27	37	18.5					20.5
	VCAP50-SIR14060-3DT				20.6	14	60	27	37	23					25.0
	VCAP50-SIR17070-3DT			26.2	17	70	32	47	27.5	30.5					
	VCAP50-SIR20090-3DT			32.2	20	90	40	67	33	36.5					
	VCAP50-SIR24105-3DT			40.2	24	105	45	82	40	44.5					
	VCAP63-SIR14070-3DT			63	20.5	14	70	27	45	23	25.0	SA3T	SY3T	K3T	Y13
	VCAP63-SIR17075-3DT				26.2	17	75	32	50	27.5	31.0				
	VCAP63-SIR20090-3DT				32.2	20	90	40	65	33	36.5				
	VCAP63-SIR24105-3DT				40.2	24	105	45	80	40	44.5				

All insert screws max. torque 2.0 Nm.

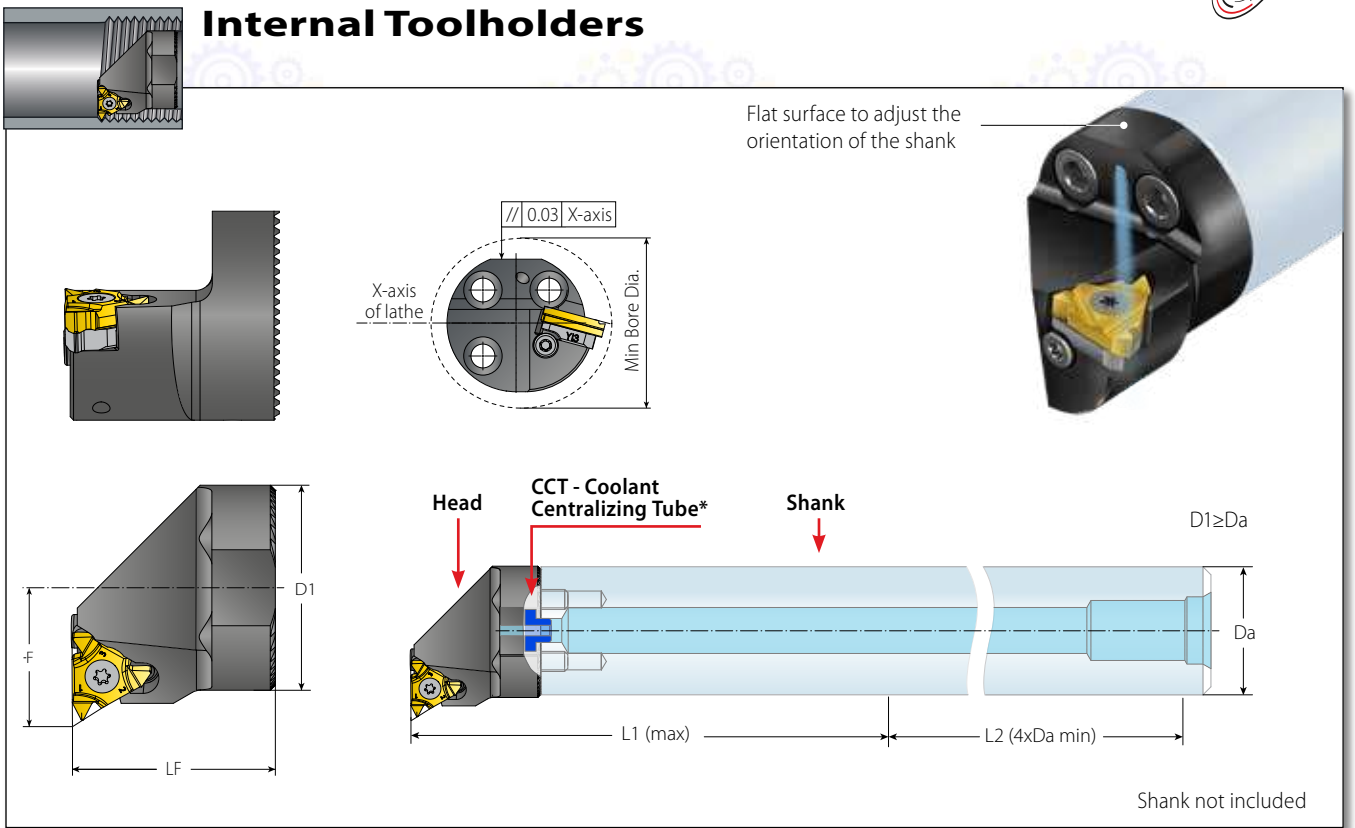

MACH TT Smooth Cut

Insert Size	Ordering Code	Dimensions mm							Spare Parts				
		D1	Da		F	L1 max	LF	Min. Bore Dia.	Insert Screw	Anvil Screw	Insert Key	Anvil	CCT - Coolant Centralizing Tube*
3/8"	VAS32-IR3222-3DT	32.3	32	1.25	22	160	32.25	40	SA3T (2.0 Nm)	SY3T	K3T	Y13	CCT12
	VAS40-IR3227-3DT	40	40	1.50	27	200	32.25	50					

* When assembling the CCT, it is recommended to use LOCTITE 648.

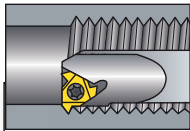

Internal Toolholders

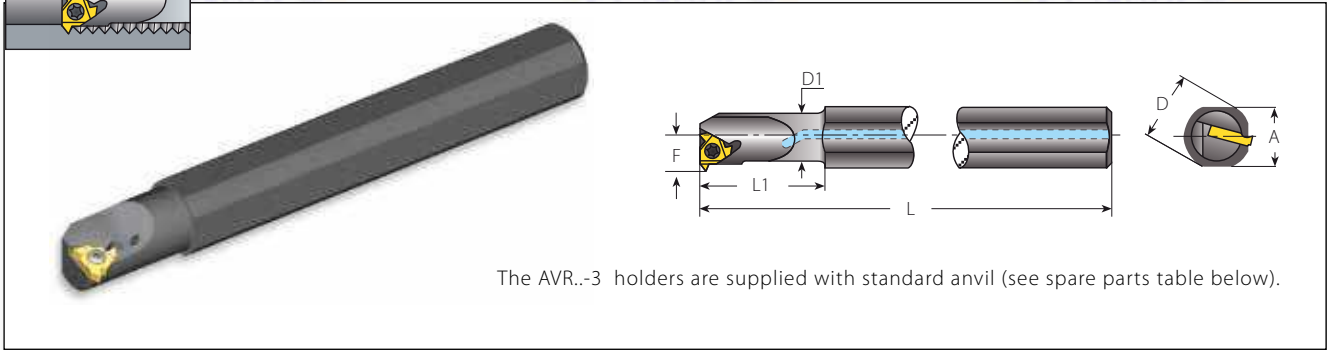

The AVR..-3 holders are supplied with standard anvil (see spare parts table below).

Standard

Spare Parts

Insert Size	Ordering Code	Dimensions mm						Min. Bore Dia.					
		IC	RH/LH	A	L	L1 (max)	D		D1	F	mm	Insert Screw	Anvil Screw
3/8"	NVR13-3	18.0	180	32	20	12.7	10.3	17	SN3T	-	K3T	-	-
	NVR16-3	18.0	180	40	20	16.0	11.5	20					
	NVR16D-3	15.2	150	64	16	16.0	11.3	20					
	AVR20-3	18.0	180	80	20	20.0	13.4	24	SA3T	SY3T	K3T	YI3	YE3
	AVR25-3	29.0	250	60	32	25.0	16.3	29					
	AVR25D-3	22.6	200	100	25	24.6	16.1	29					
	AVR32-3	29.0	250	128	32	32.0	19.6	36					
1/2"	AVR40-3	36.0	300	160	40	40.0	23.8	44	SN4T	-	K4T	-	-
	NVR20-4	18.0	180	80	20	20.0	15.6	27					
	AVR25-4	29.0	250	60	32	25.0	17.4	32					
	AVR25D-4	22.6	200	100	25	24.6	17.2	32					
	AVR32-4	29.0	250	128	32	32.0	21.5	39					
5/8"	AVR40-4	36.0	300	160	40	40.0	25.8	47	SA4T	SY4T	K4T	YI4	YE4
	AVR50-4	45.0	350	200	50	50.0	30.8	57					
	AVR32-5	29.0	250	128	32	32.0	22.4	40					
	AVR40-5	36.0	300	160	40	40.0	26.4	48					
	AVR50-5	45.0	350	200	50	50.0	31.4	58					
	AVR60-5	54.0	400	240	60	60.0	36.4	69	SA5T	SY5T	K5T	YI5	YE5

The above toolholders have a 1.5° helix angle. For other helix angles, see page 72.
Toolholders with prefix "N" cannot be used with an anvil.

The above toolholders are for RH inserts. For LH inserts, add LH to the toolholder's ordering code (Example: NVR10-2 LH).

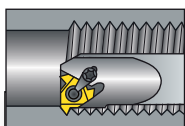

Internal Toolholders

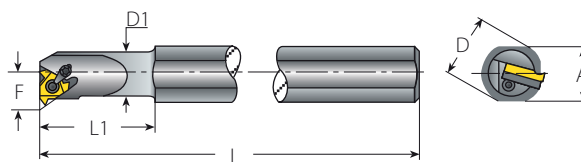

The AVR...-3C holders are supplied with standard anvil (see spare parts table below).

Standard with Clamp (Dual System, Screw or Clamp)

Insert Size	Ordering Code	Dimensions mm							Min. Bore dia.	Spare Parts					
		IC	RH	A	L	L1	D	D1		F	mm	Insert Screw	Anvil Screw	Clamp	Torx Key
3/8"	AVR20-3C	18.0	180	50	20	20.0	13.4	24							
	AVR25-3C	28.0	250	60	32	25.0	16.3	29							
	AVR25D-3C	22.6	200	45	25	24.6	16.1	29	SA3T	SY3T	C3	K3CT	YI3	YE3	
	AVR32-3C	29.0	250	60	32	32.0	19.6	36							
1/2"	AVR40-3C	36.0	300	60	40	40.0	23.8	44							
	AVR25-4C	29.0	250	60	32	25.0	17.4	32							
	AVR25D-4C	22.6	200	45	25	24.6	17.2	32	SA4T	SY4T	C4	K4T	YI4	YE4	
	AVR32-4C	29.0	250	60	32	32.0	21.5	39							
5/8"	AVR40-4C	36.0	300	60	40	40.0	25.8	47							
	AVR32-5C	29.0	250	60	32	32.0	22.4	40	SN5T	SY5T	C5	K5T	YI5	YE5	
	AVR40-5C	36.0	300	60	40	40.0	26.4	48							
	AVR50-5C	45.0	350	75	50	50.0	31.4	58	SA5T	SY5T	C5	K5T	YI5	YE5	
	AVR60-5C	54.0	400	75	60	60.0	36.4	69							

The above toolholders have a 1.5° helix angle. For other helix angles, see page 72.
Holders with coolant channel available as standard (Example AVRC20-3C).

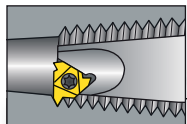

Internal Toolholders

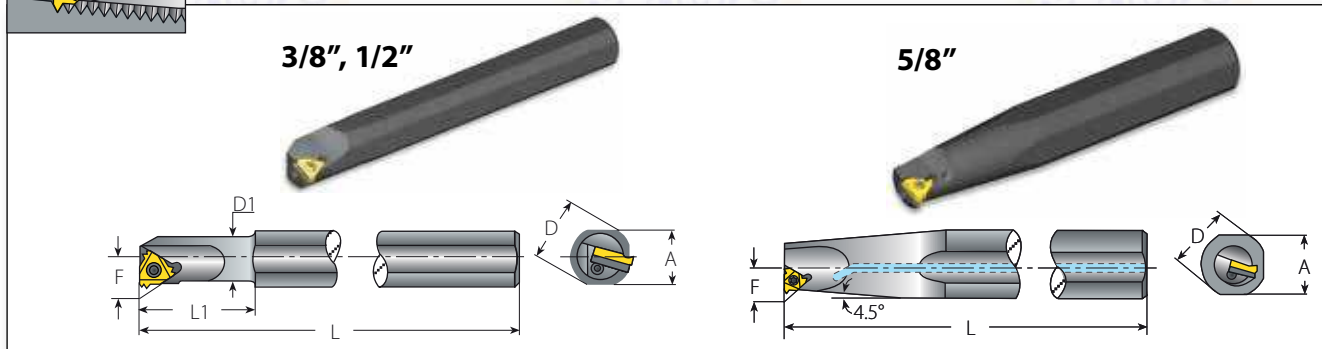

Oil & Gas

Insert Size	Ordering Code	Thread Form	Connection No. or Size	Dimensions mm				Helix Angle	Spare Parts				
				A	L	D	F		Insert Screw	Anvil Screw	Torx Key	Anvil RH	Anvil LH
3/8"	AVRC25-3-APIRD	APIRD 8 APIRD 10	2.375"-20" 1.315"-3.5"	29	250	25	14.5	1					
	AVRC32-3-APIRD	APIRD 8 APIRD 10	2.375"-20" 1.66"-3.5"	29	250	32	19.6	1	SA3T	SY3T	K3T	YEI3-APIRD	
	AVRC40-3-APIRD	APIRD 8 APIRD 10	2.375"-20" 1.9"-3.5"	36	300	40	22	1					
1/2"	AVRC40-4BUT/API	5BUT, V.038R, V.040 V.050, V.055	4 1/2"-20"	36	300	40	24.2	0	SA4T	SY4T	K4T	YEI4-API-1P YEI4-5BUT	
			NC10-NC77 all sizes										
5/8"	AVR50-5OIL	V.038R, V.040 V.050, V.055	NC23-NC38	45	300	50	22.6	1.5	SA5T	SY5T	K5T	YI5OIL YE5OIL	
	AVRC50-5OIL	V.038R, V.040 V.050, V.055	NC23-NC38										
	AVR80-5OIL	V.038R, V.040 V.050, V.055	NC40-NC77	72	400	80	39.7	1.5					
	AVRC80-5OIL	V.038R, V.040 V.050, V.055	NC40-NC77										

Toolholders ordered with an internal coolant channel have an internal BSP 1/2" thread for connection to the flexible coolant pipe.

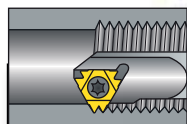

Internal Toolholders

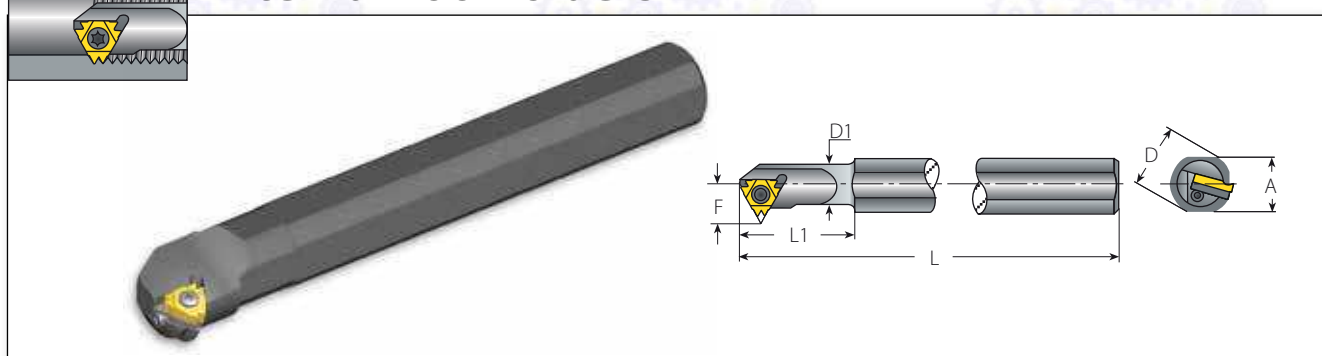

Z+ Style

Insert Size	Ordering Code	Dimensions mm							Min. Bore dia. mm	Spare Parts				
		A	L	L1	D	D1	F	Insert Screw		Anvil Screw	Torx Key	Anvil RH	Anvil LH	
1/2"Z	AVR32-4Z	29	250	60	32	32	25.5	42	SA4T	SY4T	K4T	YI4Z	YE4Z	
	AVR40-4Z	36	300	60	40	40	29.5	51						

All Z+ style toolholders have a 1.5° helix angle.

The above toolholders are for RH inserts. For LH inserts, add LH to the toolholder's ordering code (Example: AVR 50-5OIL LH).



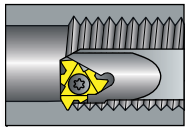

Internal Toolholders

FLINE

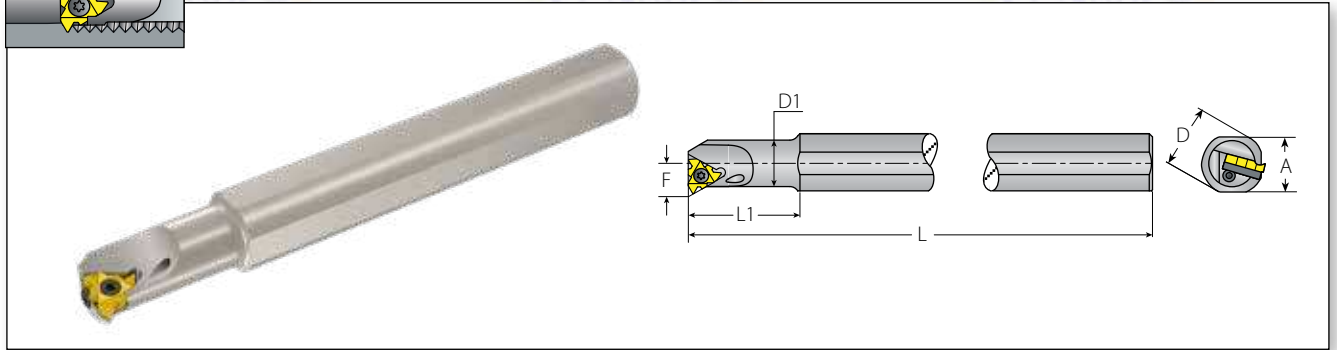

F-Line Standard

Insert Size	Ordering Code	Dimensions mm							Min. Bore dia.
IC	RH	A	L	L1	D	D1	F	mm	
1/2" F	AVRC25-4F	29.0	250	60	32	25.0	17.9	32	
	AVRC25D-4F	22.6	200	100	25	24.6	17.9	32	
	AVRC32-4F	29.0	250	128	32	32.0	21.6	39	
	AVRC40-4F	36.0	300	160	40	40.0	25.4	47	
	AVRC50-4F	45.0	350	200	50	50.0	30.6	57	

Spare Parts



Insert Screw Anvil Screw Torx Key Anvil RH

SA4T SY4T K4T YI4F

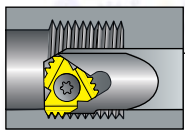

Internal Toolholders

FLINE

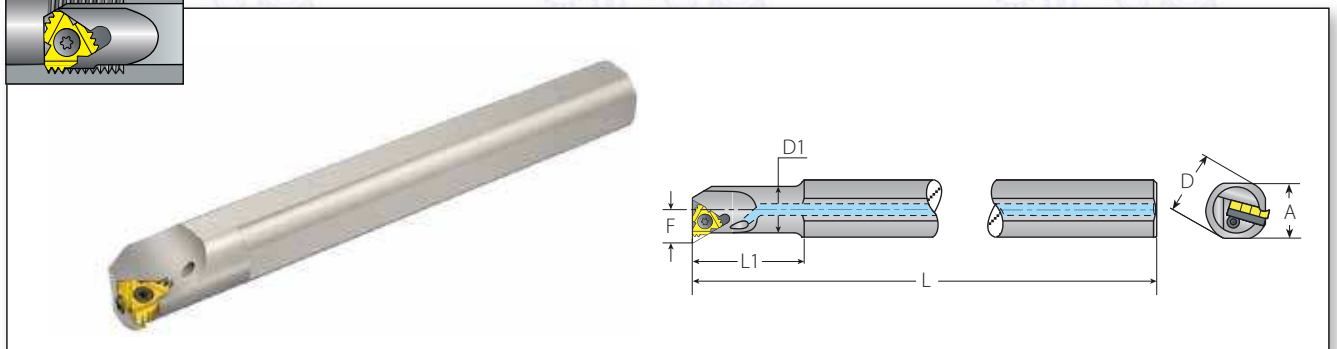

F-Line Multi+ Style

Insert Size	Ordering Code	Dimensions mm							Min. Bore dia.
IC	RH	A	L	L1	D	D1	F	mm	
1/2" F	AVRC25-4MF	29.0	250	60	32	25.0	17.9	32	
	AVRC25D-4MF	22.6	200	100	25	24.6	17.9	32	
	AVRC32-4MF	29.0	250	128	32	32.0	21.4	39	
	AVRC40-4MF	36.0	300	160	40	40.0	25.6	47	
	AVRC50-4MF	45.0	350	200	50	50.0	30.6	57	

Spare Parts



Insert Screw Anvil Screw Torx Key Anvil RH

SA4T SY4T K4T YI4M2F

ТОВ «СМАРТТЕК ІНЖИНІРИНГ», Т. +380-50-396-90-96, info@smarttec.com.ua, https://www.smarttec.com.ua



СМАРТТЕК
РОЗУМНІ ТЕХНОЛОГІЇ

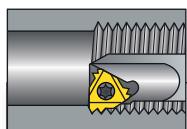

Internal Toolholders

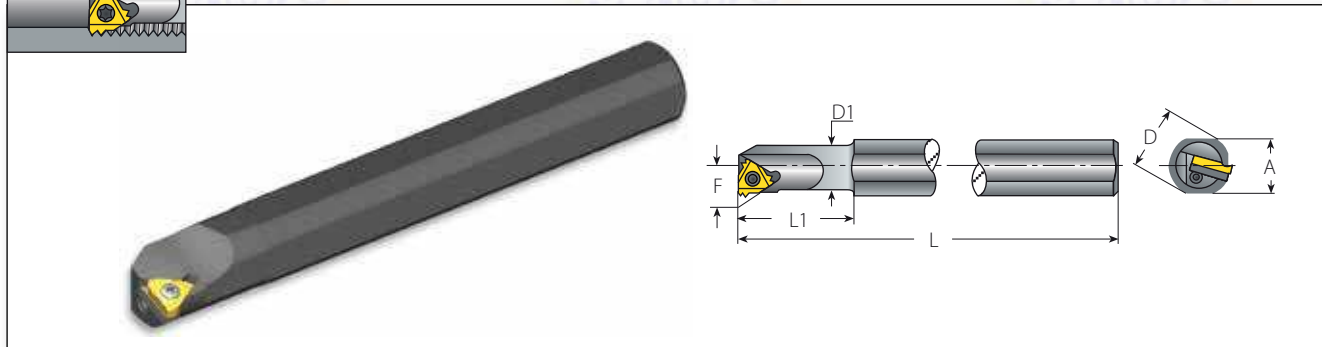

M+ Style

Insert Size	Ordering Code	Dimensions mm							Min. Bore Dia.	Spare Parts				
		IC	RH	A	L	L1 (max)	D	D1		F	mm	Insert Screw	Anvil Screw	Torx Key
5/8" M	AVR32-5M	29	250	128	32	32	22.4	40	SN5T	SY5T	K5T	YI5M	YE5M	
	AVR40-5M	36	300	160	40	40	26.4	48	SA5T	SY5T	K5T	YI5M	YE5M	
	AVR50-5M	45	350	200	50	50	31.4	58						
	AVR60-5M	54	400	240	60	60	36.4	69						

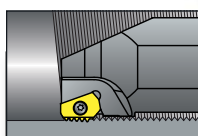

Internal Toolholders

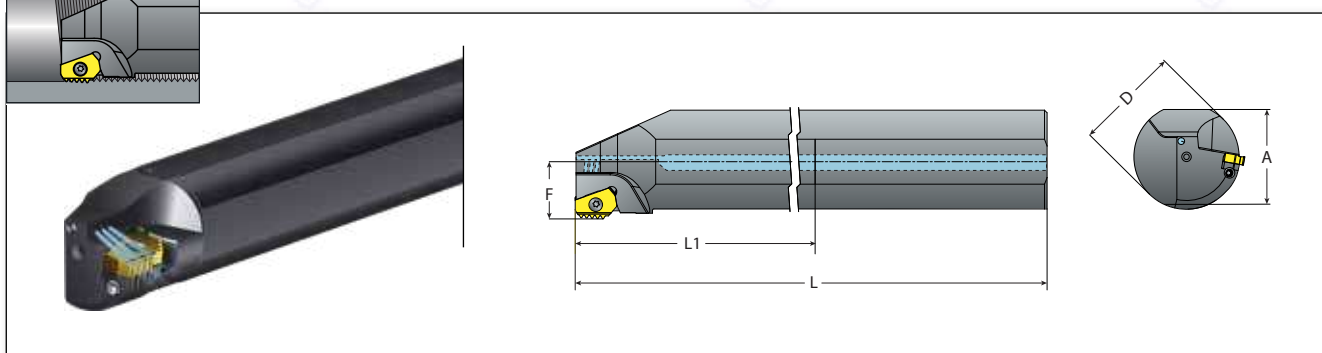

MACH 25 with Coolant

Insert Size	Ordering Code	Dimensions mm							Minimum Bore Ø	Spare Parts			
		RH	A	L	L1 max	D	F	mm		Insert Screw	Anvil Screw	Torx Key	Anvil
25	AVRC40-25DT	36	300	160	40	23.3	60	SA4T	SY25TW	K6T	YI25M		
	AVRC50-25DT	45	350	200	50	28.3	70						
	AVRC60-25DT	54	400	240	60	33.3	80						

All MACH 25 style toolholders have a 0° helix angle.



14D Internal Toolholders

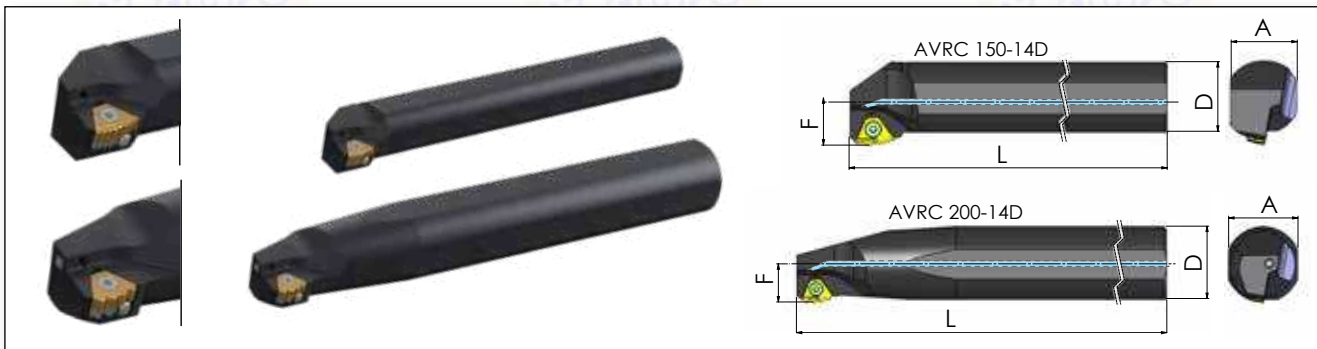

14D Standard

Insert Size	Ordering Code	Dimensions mm					Spare Parts			
		A	L	D	F	Min. Bore Dia.	Insert Screw	Anvil Screw & Washer	Insert Key	Anvil Key
14D	AVRC40-14D	37	300	40	26	54.5	SA5T	M4x6(14D)	K5T	KT15
14D	AVRC50-14D	46	300	50	25	54.5	SA5T	M4x6(14D)	K5T	KT15

The above toolholders have a 1.5° helix angle. For other helix angles, see page 72.
 Holders with coolant channel available as standard (Example AVRC32-5M).

14D Internal Toolholders with Clamp

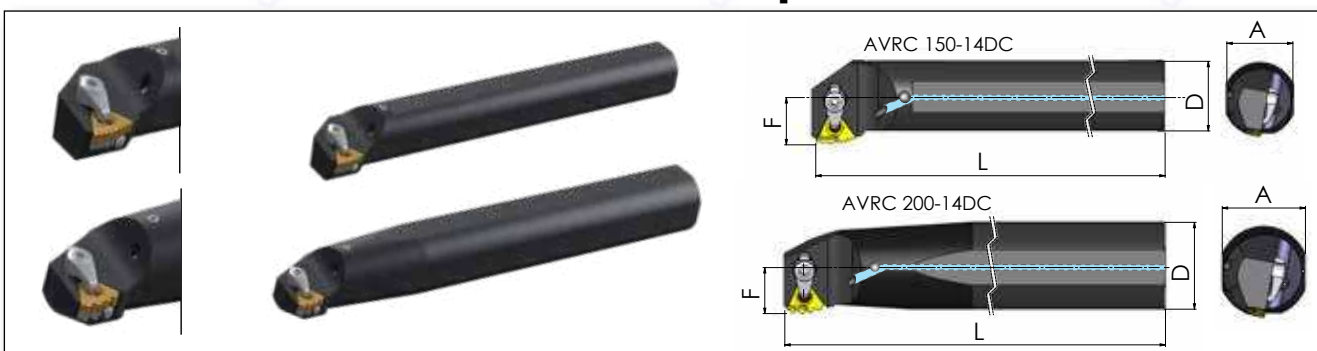

14D Standard with Clamp

Insert Size	Ordering Code	Dimensions mm					Spare Parts				
		A	L	D	F	Min. Bore Dia.	Insert Screw	Anvil Screw & Washer	Clamp	Insert Key	Anvil Key
14D	AVRC40-14DC	37	300	40	26	54.5	SA5T	M4x6(14D)	C5	K5T	KT15
14D	AVRC50-14DC	46	300	50	25	54.5	SA5T	M4x6(14D)	C5	K5T	KT15

14D holders are supplied without anvils. For specific applications, please use the anvils indicated in the table on page 73.

Toolholders ordered with an internal coolant channel have an internal BSP 1/2" thread for connection to the flexible coolant pipe.

The above toolholders are for RH inserts. For LH inserts, add LH to the toolholder's ordering code (Example: AVRC 40-14D LH).

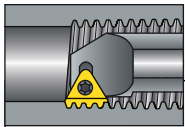

Internal Toolholders

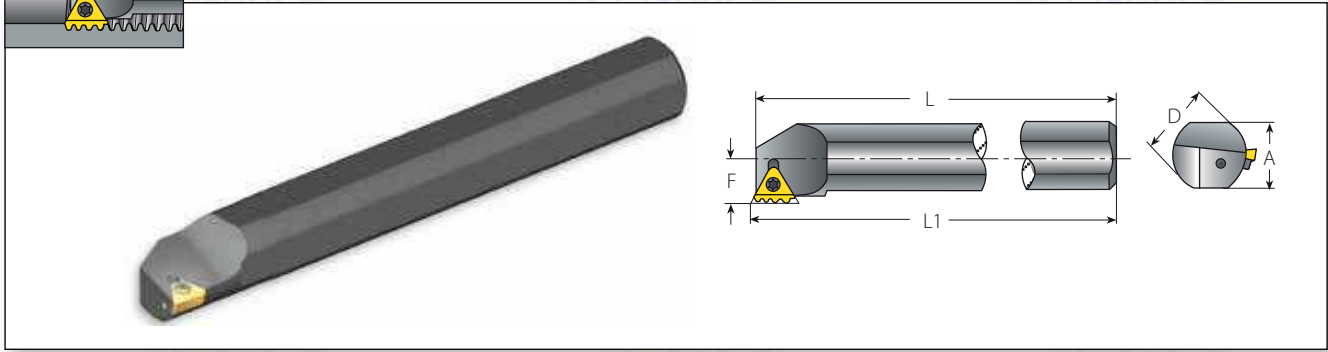

T+ Style

Insert Size	Ordering Code	Dimensions mm					Min. Bore dia.
IC	RH	A	L	L1	D	F	mm
1/2" T	AVR40-4T	36	300	302	40	23.3	60
	AVR50-4T	45	350	352	50	28.3	70
	AVR60-4T	54	400	402	60	33.3	80

Spare Parts

Insert Screw	Anvil Screw	Torx Key	Anvil Torx Key	Anvil RH/LH
SA4T	SY4K2	K4T	K2	Y4T

All T+ style toolholders have a 0° helix angle.
 Holders with coolant channel available as standard. (Example: AVRC50-4T)

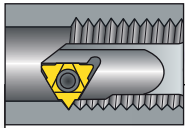

Internal Toolholders

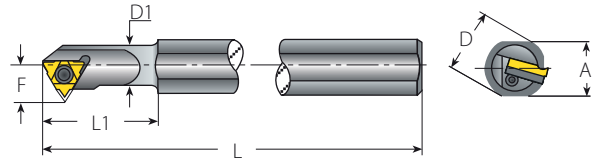

U Style

Insert Size	Ordering Code	Dimensions mm							Min. Bore dia.
IC	RH	A	L	L1	D	D1	F	mm	
1/2"U	AVR32-4U	29	250	60	32	32	25.5	42	
	AVR40-4U	36	300	60	40	40	29.5	51	
5/8"U	NVR32-5U	29	250	60	32	32	24.7	42	
	AVR40-5U	36	300	60	40	40	29.4	53	
	AVR50-5U	45	350	75	50	50	34.3	63	
	AVR60-5U	54	400	75	60	60	39.3	74	

Spare Parts

Insert Screw	Anvil Screw	Torx Key	Anvil RH	Anvil LH
SA4T	SY4T	K4T	Y14U	YE4U
SN5T	-	K5T	-	-
SA5T	SY5T	K5T	Y15U	YE5U

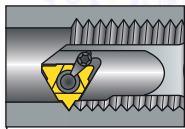

Internal Toolholders

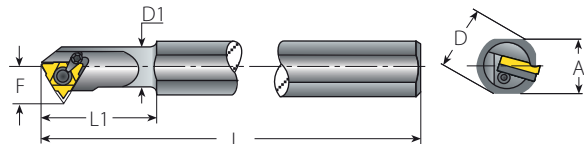

U Style with Clamp

(Dual System, Screw or Clamp)

Insert Size	Ordering Code	Dimensions mm							Min. Bore dia.
IC	RH	A	L	L1	D	D1	F	mm	
1/2"U	AVR32-4UC	29.0	250	60	32	32.0	25.5	42	
	AVR40-4UC	36.0	300	60	40	40.0	29.5	51	
5/8"U	AVR40-5UC	36.0	300	60	40	40.0	29.4	53	
	AVR50-5UC	45.0	350	75	50	50.0	34.4	63	
	AVR60-5UC	54.0	400	75	60	60.0	39.3	74	

Spare Parts

Insert Screw	Anvil Screw	Clamp	Torx Key	Anvil RH	Anvil LH
SA4T	SY4T	C4	K4T	Y14U	YE4U
SA5T	SY5T	C5	K5T	Y15U	YE5U

The above toolholders have a 1.5° helix angle. For other helix angles, see page 72.
Toolholders with prefix "N" cannot be used with an anvil.

The above toolholders are for RH inserts. For LH inserts, add LH to the toolholder's ordering code.
(Example AVRC32-4ULH or AVRC32-4UCLH).

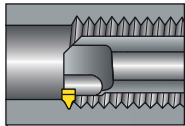

Internal Toolholders

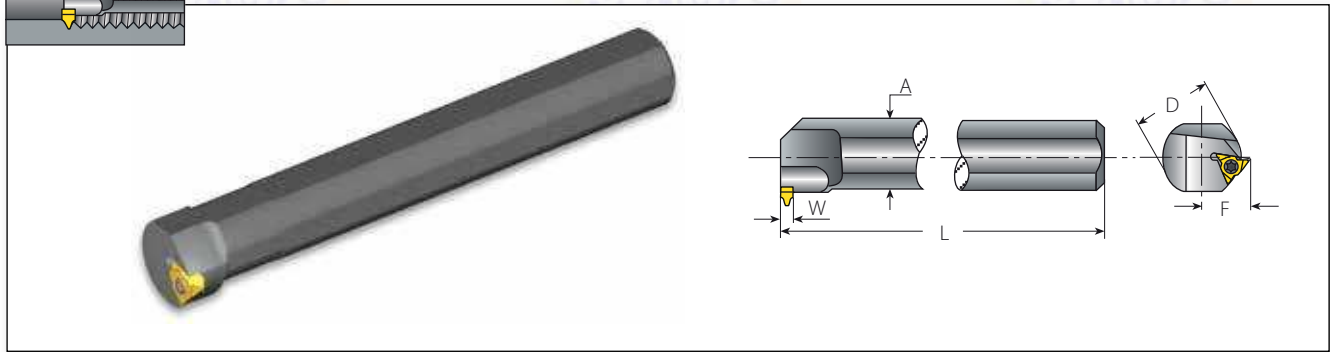

V Style

Insert Size		Ordering Code		Dimensions mm				Spare Parts	
IC	RH	A	L	D	F	W	Min. Bore dia.	Insert Screw	Torx Key
5/8"V	NVR40-5V	36	300	40	28.4	6.5	49	SN6T	K6T
	NVR50-5V	45	350	50	33.4	6.5	59		
	NVR60-5V	54	400	60	38.0	6.5	69		

The above toolholders have a 1.0° helix angle.

Special Toolholders Solutions

Tailor-made toolholder solutions are available upon request through your local Vargus distributor.

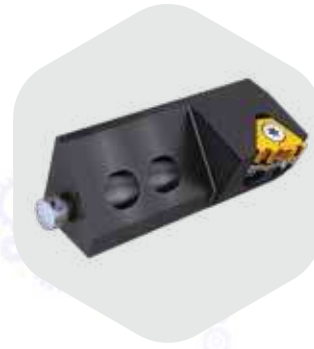

ТОВ «СМАРТТЕК ІНЖИНІРИНГ», Т. +380-50-396-90-96, info@smarttec.com.ua, <https://www.smarttec.com.ua>

Calculating the Helix Angle and Choosing The Right Anvil

Flank Clearance Angle α (For External Inserts)

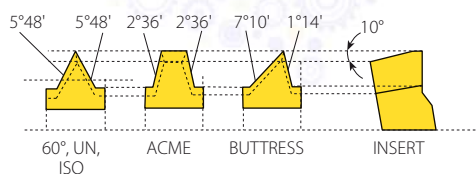

Vardex toolholders are designed to tilt the insert when seated in the toolholder (10° for external, 15° for internal tooling).

This results in the differing flank clearance angles, based on the geometry of the insert. To ensure that the side of the insert cutting edge will not rub on the workpiece, it is most important that the insert helix angle be correct - especially in profiles with small enclosed flank angles. This correction is provided by Vardex anvils.

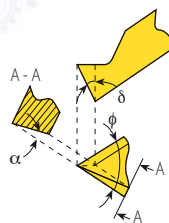

$$\alpha = \arctan(\tan \frac{\phi}{2} \times \tan \delta)$$

Where: α - Flank clearance angle
 δ - Tilt angle
 ϕ - Enclosed flank angle

Calculating the Helix Angle β

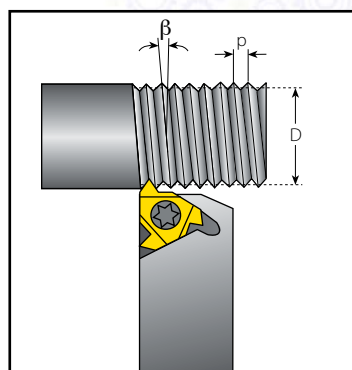

The helix angle is calculated by the following formula:

$$\beta = \arctan \frac{P \times N}{\pi \times D}$$

β - Helix angle [°]
 P - Pitch [mm]
 N - No. of starts
 D - Pitch diameter [mm]
 Lead = P x N

The helix angle can also be found from the diagram below.

Helix Angle Diagram

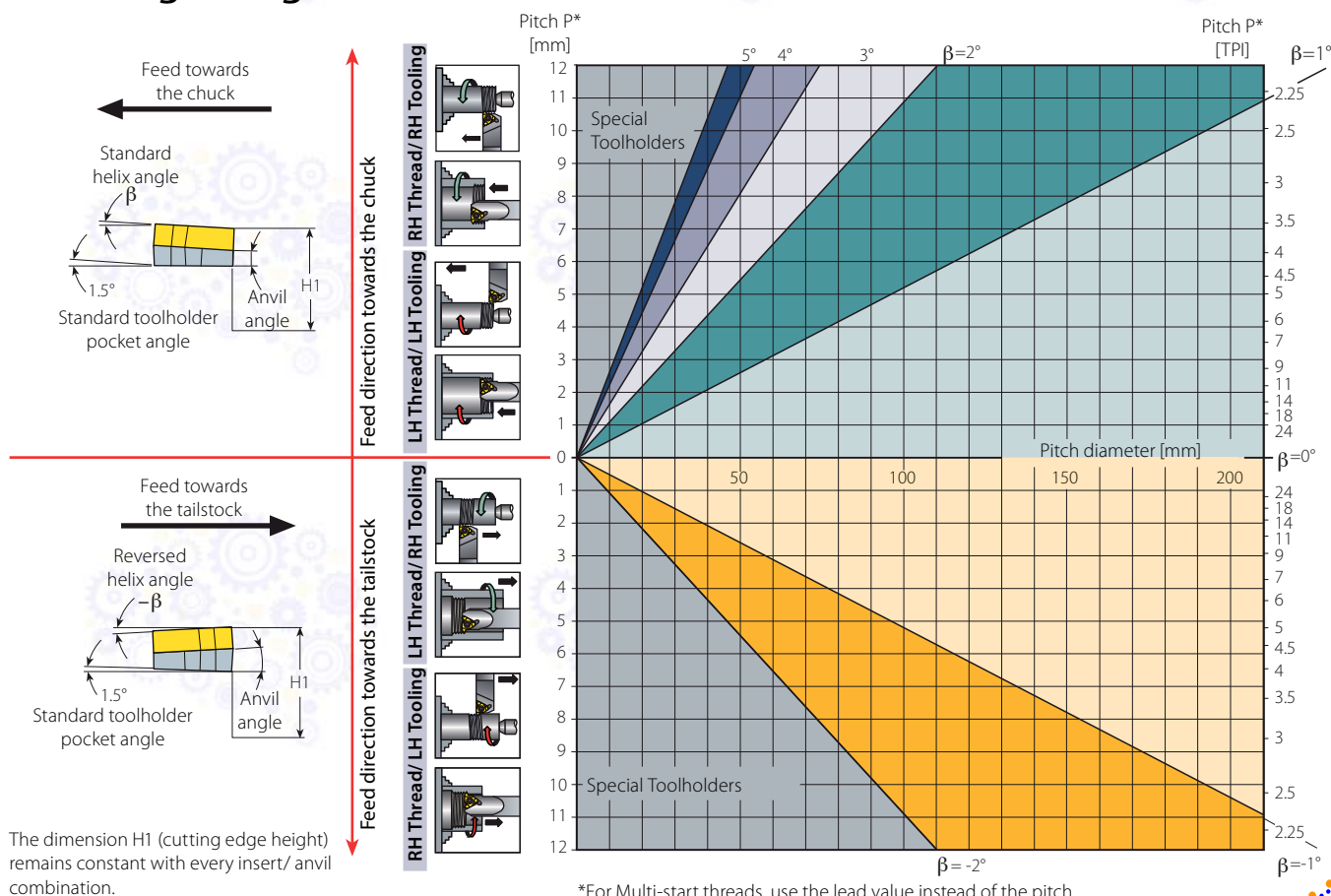

Number of Passes for MACH TT

Pitch	mm	0.70	0.75	1.00	1.25	1.50	1.75	2.00	2.50	3.00	3.50	4.00	4.50	5.00	5.50	6.00
	TPI	36	32	24	20	16	14	12	10	8	7	6	5.5	5	4.5	4
No. of passes - MACH TT*		2-4	2-4	2-4	3-4	3-4	4-6	4-6	5-7	5-7	6-8	6-8	7-9	8-10	9-12	11-14
<i>In comparison (for your reference): No. of passes for Standard tools</i>		(4-7)	(4-7)	(4-8)	(5-9)	(6-10)	(7-12)	(7-12)	(8-14)	(9-16)	(10-18)	(11-18)	(11-19)	(12-20)	(12-20)	(12-20)

* For internal threading an additional pass is required.

Infeed Methods and Type of Passes

MACH TT 3/8" EX & IN Tools - Flank Infeed method

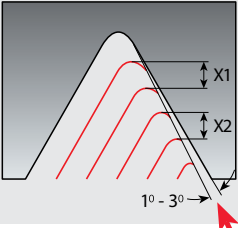

1. Use the flank infeed method (modified) with 1° - 3°.
2. Use the constant depth type of passes. X1 = X2

MACH TT 1/2" EX Tools - Radial Infeed method

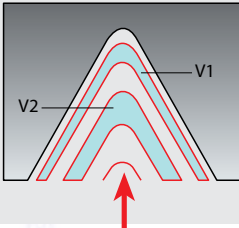

1. Use the Radial Infeed method.
2. Use the constant volume type of passes. V1 = V2

Thread Turning Methods for Symmetrical Inserts

Thread	Inserts & Toolholder	Rotation	Feed Direction	Helix Method	Drawing
Right Hand External	EX RH	Counterclockwise	Towards chuck	Regular	1
Left Hand External	EX RH	Counterclockwise	From chuck	Reversed	6
Right Hand Internal	IN RH	Counterclockwise	Towards chuck	Regular	3
Left Hand Internal	IN RH	Clockwise	From chuck	Reversed	8

MACH TT tools are designed for Right Hand applications, but can also be used for Left Hand threads.

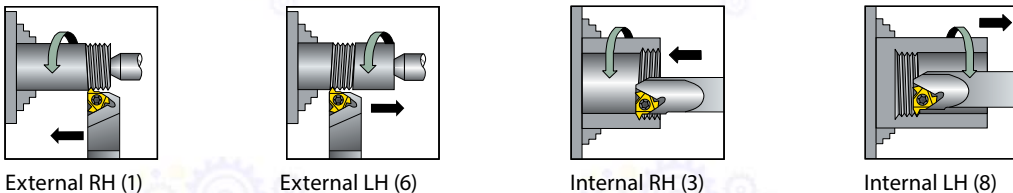

Anvils

Resultant Helix Angle		2.5°	1.5°	0.5°	
Insert Size	Holder	Ordering Code			
IC	L mm				
3/8"	16	ER	YE3-1P	YE3	YE3-1N
1/2"	22	ER	YE4-1P	YE4	YE4-1N
3/8"	16	IR	YI3-1P	YI3	YI3-1N

Insert & Toolholder Combinations

- MACH toolholders are suitable with MACH inserts only
- Standard toolholders can be used with MACH inserts **but is less recommended**

	MACH TT Insert	Standard Insert
MACH TT Holder	✓✓✓	✗
Standard Holder	✓✓	✓

Anvils

Resultant Helix Angle		4.5°	3.5°	2.5°	1.5°	.5°	0°	-.5°	-1.5°	
Insert Size		Holder								
IC mm		Ordering Code								
L mm										
3/8"	16	ER / IL	YE3-3P	YE3-2P	YE3-1P	YE3	YE3-1N	YE3-1.5N	YE3-2N	YE3-3N
		EL / IR	YI3-3P	YI3-2P	YI3-1P	YI3	YI3-1N	YI3-1.5N	YI3-2N	YI3-3N
1/2"	22	ER / IL	YE4-3P	YE4-2P	YE4-1P	YE4YEI4-APIYEI4-5BUT	YE4-1N	YE4-1.5N	YE4-2N	YE4-3N
		EL / IR	YI4-3P	YI4-2P	YI4-1P	YI4YEI4-APIYEI4-5BUT	YI4-1N	YI4-1.5N	YI4-2N	YI4-3N
1/2"F		ER	YE4F-3P	YE4F-2P	YE4F-1P	YE4F	YE4F-1N	YE4F-1.5N		
		IR	YI4F-3P	YI4F-2P	YI4F-1P	YI4F	YI4F-1N	YI4F-1.5N		
1/2"F 2M+	23	ER	—	—	YE4M2F-1P	YE4M2F	YE4M2F-1N	YE4M2F		
1/2"F 3M+		IR	—	—	YE4M3F-1P	YE4M3F	YE4M3F-1N	YE4M3F-1.5N		
1/2"F 2M+		ER	—	—	YI4M2F-1P	YI4M2F	YI4M2F-1N	YI4M2F-1.5N		
1/2"U		22	ER / IL	YE4U-3P	YE4U-2P	YE4U-1P	YE4U	YE4U-1N	YE4U-1.5N	YE4U-2N
5/8"	27	ER / IL	YE5-3P	YE5-2P	YE5-1P	YE5	YE5-1N	YE5-1.5N	YE5-2N	YE5-3N
		EL / IR	YI5-3P	YI5-2P	YI5-1P	YI5	YI5-1N	YI5-1.5N	YI5-2N	YI5-3N
5/8"U	27	ER / IL	YE5U-3P	YE5U-2P	YE5U-1P	YE5U	YE5U-1N	YE5U-1.5N	YE5U-2N	YE5U-3N
		EL / IR	YI5U-3P	YI5U-2P	YI5U-1P	YI5U	YI5U-1N	YI5U-1.5N	YI5U-2N	YI5U-3N
3/8"M	16	ER / IL			YE3M-1P	YE3M	YE3M-1N	YE3M-1.5N	YE3M-2N	
		EL / IR			YI3M-1P	YI3M	YI3M-1N	YI3M-1.5N		
1/2"M	22	ER / IL			YE4M-1P	YE4M	YE4M-1N	YE4M-1.5N	YE4M-2N	
		EL / IR			YI4M-1P	YI4M	YI4M-1N	YI4M-1.5N		
5/8"M	27	ER / IL				YE5M	YE5M-1N	YE5M-1.5N		
		EL / IR				YI5M	YI5M-1N	YI5M-1.5N		
1/2"Z	22	ER / IL			YE4Z-1P	YE4Z	YE4Z-1N			
		EL / IR			YI4Z-1P	YI4Z	YI4Z-1N			

Standard Anvil		U Style Anvil		M Style Anvil		Z Style Anvil		T Style Anvil		F.LINE Anvil		F.LINE M+ Style Anvil	
ER / IL	EL / IR	ER / IL	EL / IR	ER / IL	EL / IR	ER / IL	EL / IR	ER / IL	EL / IR Same anvil turned over	ER	IR	ER	IR

Oil&Gas Technical Data

Cutting Speed Recommendations for Materials Specified by API STB 5

Material	J55-K55	N80-L80-C95-TN70	TN95-P110-TN110
Cutting Speed (m/min)	170-200	150-180	130-160

Cutting Pass Division Recommendations for Multi Tooth Inserts

The following table provides the optimal cutting pass division options, depending on the material, machine stability and clamping conditions:

Application	No. of Passes/ Pass No.	1	2	3	4	5	6
APIRD 8 Ex, In	3 passes	0.89	0.81	0.11			
	4 passes	0.6	0.58	0.52	0.11		
	5 passes	0.47	0.47	0.43	0.33	0.11	
	6 passes	0.39	0.41	0.37	0.29	0.24	0.11
APIRD 10 Ex, In	3 passes	0.67	0.63	0.11			
	4 passes	0.44	0.45	0.41	0.11		
	5 passes	0.34	0.37	0.33	0.26	0.11	
	6 passes	0.28	0.32	0.29	0.22	0.19	0.11
BUT 5 Ex, In	3 passes	0.760	0.705	0.110			
	4 passes	0.506	0.501	0.458	0.110		
	5 passes	0.395	0.409	0.374	0.287	0.110	
	6 passes	0.329	0.353	0.324	0.249	0.210	0.110
OTTM 5 Ex, In	3 passes	0.760	0.730	0.110			
	4 passes	0.506	0.501	0.483	0.110		
OTTG 5 Ex, In	5 passes	0.395	0.409	0.374	0.312	0.110	
	6 passes	0.329	0.353	0.324	0.249	0.235	0.110

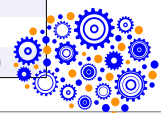

Oil&Gas Anvils

Standard	Application	Anvils with Protected Second Cutting Edge			
		Ordering Code External Application		Ordering Code Internal Application	
API Round Casing & Tubing	10 TPI from $\varnothing 2\frac{3}{8}$ " and up	Y14DER-10APIRD (4 teeth)		Y14DIR-10APIRD (4 teeth)	
	10 TPI from $\varnothing 2\frac{3}{8}$ " and up	Y14DER10APIRD-3+ (3 teeth)		Y14DIR10APIRD-3+ (3 teeth)	
	8 TPI from $\varnothing 2\frac{3}{8}$ " and up	Y14DER-8APIRD		Y14DIR-8APIRD	
API Buttress Casing	5 TPI for $\varnothing 4\frac{1}{2}$ " - $\varnothing 9\frac{5}{8}$ "	Y14DER-5 BUT		Y14DIR-5 BUT	
	5 TPI for $\varnothing 10\frac{3}{4}$ " and up	Y14DER-5BUT-4N		Y14DIR-5BUT-4N	

Oil&Gas Anvils

Resultant Helix Angle	3°	2°	1°	0°	0.5°
Insert Size					
3/8 APIRD			YEI3-APIRD		
1/2 API	YEI4-API-3P	YEI4-API-2P	YEI4-API-1P		
1/2 BUT					YEI4-BUT-0.5N

Anvils

	Resultant Helix Angle 0°		
	Insert Size	Holder	Ordering Code
	IC	L mm	
	25S/25D	25 ER	YE25M
	25S/25D	25 IR	YI25M



Grades and their Applications

Oil&Gas - General Use				
VRXP	VTXP	VKXP	VRKP	VK8 NEW
Premium submicron grade with reinforced cutting edge for the oil & gas industry. Ideal for steel and stainless steel in unstable cutting conditions. AlTiN alloyed PVD coated.	Excellent all-purpose grade, tailor-made to the oil & gas industry with reinforced cutting edge. Recommended for non-rigid cutting conditions. TiAlN coated.	General purpose grade, excellent in steel and stainless steel, and highly recommended for rigid cutting conditions. Special design with reinforced cutting edge for the oil & gas industry. TiN coated.	Specially designed for the oil and gas industry. Suitable for extreme cutting speeds. Available upon request for 14D & T+ style inserts.	High wear resistance for general purpose applications. AlTiN+TiN PVD Coating.

General Use			
VRX	VTX/VCB	VKX	VK8 NEW
Premium multipurpose submicron grade for stronger wear resistance and improved productivity. AlTiN alloyed PVD coated.	General purpose grade with tough submicron substrate. Provides good fracture toughness in non-rigid cutting conditions. TiAlN coated.	General purpose grade, excellent in steel and stainless steel, recommended for rigid cutting conditions. Ground or sintered chipbreaker styles. TiN coated.	High wear resistance for general purpose applications. AlTiN+TiN PVD Coating.

Recommended Grades and Cutting Speeds Vc [m/min] for General Use

Material Group	Vardex No.	Material	Hardness Brinell HB	Vc [m/min]				
				Coated				
				VKX(P)	VCB	VTX(P), VRX(P)	VK8	
P Steel	1	Unalloyed steel	Low carbon (C=0.1-0.25%)	125	115-190	115-190	115-190	115-175
	2		Medium carbon (C=0.25-0.55%)	150	100-175	100-165	100-175	100-165
	3		High carbon (C=0.55-0.85%)	170	90-165	90-155	90-165	90-155
	4	Low alloy steel (alloying elements≤5%)	Non hardened	180	100-180	100-180	100-180	100-165
	5		Hardened	275	75-140	75-140	75-140	75-130
	6		Hardened	350	70-135	70-135	70-135	70-125
	7	High alloy steel (alloying elements>5%)	Annealed	200	80-120	80-120	80-120	80-110
	8		Hardened	325	50-100	50-100	50-100	50-95
	9	Cast steel	Low alloy (alloying elements <5%)	200	70-130	70-130	70-130	70-120
	10		High alloy (alloying elements >5%)	225	60-120	60-120	60-120	60-110
M Stainless Steel	11	Stainless steel Ferritic	Non hardened	200	70-130	70-130	70-130	70-120
	12		Hardened	330	60-115	50-95	60-115	60-105
	13	Stainless steel Austenitic	Austenitic	180	90-140	80-120	90-140	90-130
	14		Super Austenitic	200	40-110	30-100	40-110	40-100
	15	Stainless steel Cast ferritic	Non hardened	200	90-120	90-120	90-120	90-110
	16		Hardened	330	65-110	65-110	65-110	65-100
	17	Stainless steel Cast austenitic	Austenitic	200	85-110	85-110	85-110	85-100
	18		Hardened	330	60-100	60-100	60-100	60-100
K Cast Iron	28	Malleable Cast iron	Ferritic (short chips)	130	60-70	70-120	60-70	60-70
	29		Pearlitic (long chips)	230	60-145	70-120	60-145	60-135
	30	Grey Cast iron	Low tensile strength	180	70-130	70-130	70-130	70-120
	31		High tensile strength	260	60-115	60-100	60-115	60-105
	32	Nodular SG iron	Ferritic	160	125-160	125-160	125-160	125-145
	33		Pearlitic	260	90-120	90-120	90-120	90-110
N(K) Non-Ferrous Metals	34	Aluminum alloys Wrought	Non aging	60	100-365	100-250	100-365	100-325
	35		Aged	100	80-220	80-180	80-220	80-205
	36	Aluminum alloys	Cast	75	200-400	200-400	200-400	200-370
	37		Cast & aged	90	200-280	200-280	200-280	200-260
	38	Aluminum alloys	Cast Si 13-22%	130	60-180	60-150	60-180	60-165
	39	Copper and copper alloys	Brass	90	80-225	80-210	80-225	80-210
	40		Bronze and non leaded copper	100	80-255	80-210	80-255	80-235
S(M) Heat Resistant Material	19	High temperature alloys	Annealed (Iron based)	200	45-60	45-60	45-60	45-60
	20		Aged (Iron based)	280	30-50	30-50	30-50	30-50
	21		Annealed (Nickel or Cobalt based)	250	20-30	20-30	20-30	20-30
	22		Aged (Nickel or Cobalt based)	350	15-25	15-25	15-25	15-25
	23	Titanium alloys	Pure 99.5 Ti	400Rm	140-170	140-170	140-170	140-160
	24		α+β alloys	1050Rm	50-70	50-70	50-70	50-70
H(K) Hardened Material	25	Extra hard steel	Hardened & tempered	45-50HRC	45-60	45-60	45-60	45-60
	26			51-55HRC	40-50	40-50	40-50	40-50

Grade	Application	Sample	Sample
VK8	High wear resistance for general purpose applications. AlTiN+TiN PVD Coating		





VARGUS GENius™ – The most powerful tool selector, cutting data and CNC program generating software for the metal cutting tools industry.

Thread Turning: The Vargus GENius™ guides the user to the right tool and the best cutting conditions for the application.

Thread Milling: In a few simple steps, the Vargus GENius™ provides the user with the best tool and optimal machining data, as well as the G-Code for all popular CNC machines.

The VARGUS GENius™ is free and available in 20 languages in iOS and Android Apps, Online, Desktop, and SETUP versions.

VARGUS GENius™ | Tool Selector and CNC Program Generator

Anywhere! Anytime!

The most popular and advanced thread turning and thread milling software on the market today.



Available in 4 versions at www.vargus.com



- Online interactive software
- Always on, always updated!



- Stand-alone software application
- MS Windows OS-based program
- Automatic updates



- USB memory devices
- MS Windows operating system-based program
- To install, open ZIP and click Setup



- Available for iOS and Android devices
- New responsive design!
- Use on any device, anywhere in the world!

ТОВ «СМАРТТЕК ІНЖИНІРИНГ», Т. +380-50-396-90-96, info@smarttec.com.ua, https://www.smarttec.com.ua





Oil&Gas

Professional Threading Solutions

