



SMARTTEK
РОЗУМНІ ТЕХНОЛОГІЇ

Офіційний
партнер в
Україні 

NEUMO Ehrenberg Group



GEAR MILLING

For Gear, Spline & Rack Manufacturing

**INCLUDES
EXPANSION
of DIN 5480**



METRIC

VARDEX

Advanced Threading Solutions

GEAR MILLING CATALOG

The Vardex Gear Milling Concept	3
Gear Milling Ordering Code System	5
GEAR MILLING INSERTS	
Tailor-Made Inserts for Gear, Spline and Rack Applications	6
Standard DIN 3972 Inserts for Gear Applications	7
Standard DIN 5480 Inserts for Spline Applications - EXPANDED	8
Standard ANSI B92.1 Inserts for Spline Applications	12
STANDARD TOOLHOLDERS	
Weldon Shank for IC 1/4"U	14
Weldon Shank for IC 3/8"U	14
Shell Mill for IC 3/8"U	15
Shell Mill for IC 1/2"U	16
Shell Mill for IC 1/2"UT	17
Shell Mill for IC 5/8"U	18
Shell Mill for IC 5/8"UT	19
Disc Mill for IC 1/4"U	20
Disc Mill for IC 3/8"U	20
TAILOR-MADE SOLID CARBIDE	
Solid Carbide Gear Milling	21
TECHNICAL DATA	
Recommended Grades and Cutting Speeds	22
Gear Milling Request Form	23



GEAR MILLING

Advanced Technologies for Gear, Spline and Rack Manufacturing

Vardex gear milling tools offer a competitive alternative to the traditional Hob system with multi-flute indexable carbide inserts for **super-fast machining with absolute price/performance advantages over existing technologies.**

NEW CONCEPT FOR GEAR MILLING TOOLS

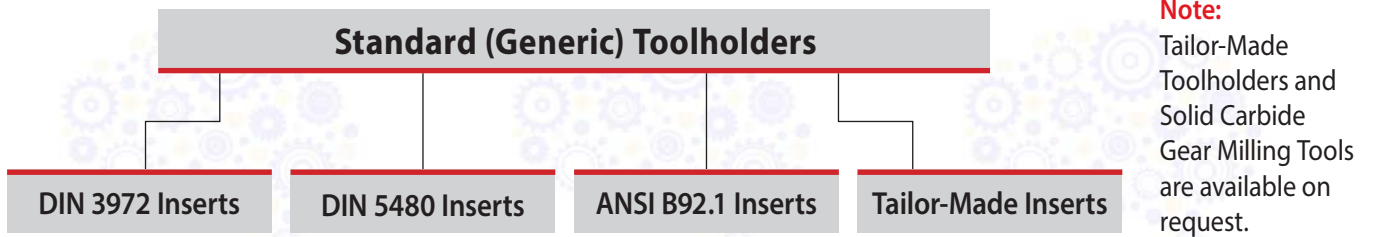

Standard (Generic) Gear Milling Holders (End Mill, Shell Mill, Disc Mill) are now suitable for all standard inserts (DIN 3972, DIN 5480, ANSI B92.1) and tailor-made inserts.

The standard toolholder enables the use of the **same** toolholder for the **same** IC type inserts.

No need for special toolholders for each individual profile!

Tailor-Made Toolholders According to the Specific Insert Profile

BEFORE

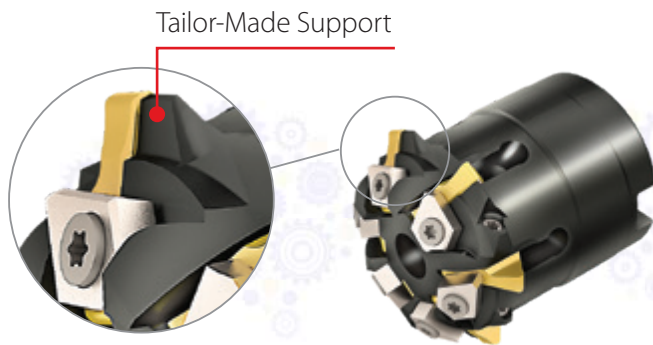

Standard (Generic) Toolholders For All Inserts with the Same IC Type

NEW

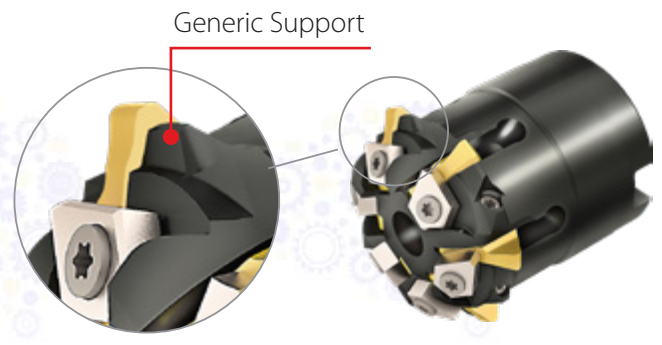

Advantages of the Vargus Gear Milling System

- Shorter machining time - at least 50% less machining cycle time over other methods
- Carbide inserts with semi partial & partial designed for single pass machining
- Long tool life and high accuracy
- Excellent surface finish
- Simplified machining - easy set-up and use on standard 3.5 axis CNC milling machines
- Complete the job with Vargus Gear Milling Tools - no need for additional machining
- High precision machining

For example:

- Gears: Up to Class 7 according to DIN 3962 and DIN 3967 or Class 9 according to AGMA
- Involute Splines: According to DIN 5480 or ANSI B92.1
- Straight Side Splines: According to ISO 14

ТОВ «СМАРТТЕК ІНЖИНІРИНГ», Т. +380-50-396-90-96, info@smarttec.com.ua, https://www.smarttec.com.ua



Gear Milling Tool Types

Standard (Generic) Tools



End Mill



Shell Mill



Disc Mill

Tailor-Made Tools

- Toolholders (End Mill, Shell Mill, Disc Mill) with indexable inserts
- Solid Carbide

Major Applications

GEAR



VARDEX Gear milling tools are suitable for machining both straight and helical teeth covering modules from 0.5-6.0mm or DP 52-4

SPLINE



VARDEX Spline milling tools are suitable for machining both involute or straight-sided profiles, covering modules from 0.5-8.0mm or DP 48/96-4/8

RACK

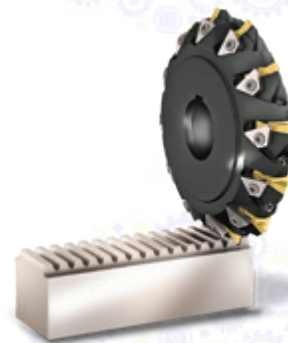

VARDEX Rack milling tools are suitable for covering modules from 0.5-6.0mm or DP 52-4

Gear Milling Ordering Code System

Gear Milling Tailor-Made and Standard DIN 5480 Inserts

5	U	T	E	W340	M	1.25	Z55	5480	GM	VBX	210/..., 310/...
1	2	3	4	5	6	7	8	9	10	11	12
1 - Insert Size 2 - IC1/4" 3 - IC 3/8" 4 - IC 1/2" 5 - IC5/8"	2 - Insert Style U - U Style 	3 - No. of Cutting Edges T - Single None - 3	4 - Application E - External	5 - Reference Diameter 15-380	6 - Module M - Module	7 - Module or DP Value M 0.5 - 6.0 DP 52-40	8 - No. of Gear / Spline Teeth Z...	9 - Standard 5480 - DIN 5480 None - Special	10 - Product Line GM - Gear Milling	11 - Grade VBX	12 - Special Insert No. 210/... 310/... None - Standard Insert

Gear Milling Standard DIN 3972 and ANSI B92.1 Inserts

5	U		E	M	2.5	Z55-134	N7	GM	VBX
1	2	3	4	5	6	7	8	9	10
1 - Insert Size 2 - IC1/4" 3 - IC 3/8" 4 - IC 1/2" 5 - IC5/8"	2 - Insert Style U - U Style 	3 - No. of Cutting Edges T - Single None - 3	4 - Application E - External	5 - Module or DP M - Module DP - Diametral Pitch	6 - Module or DP Value M 1 -25 DP 12/24 - 16/32	7 - Teeth Range Gear Zmin 12... Zmax ∞	8 - Milling Cutter No. 1 - 12	9 - Product Line GM - Gear Milling	10 - Grade VBX

Gear Milling Holders (Weldon Shank)

GMG	E	5	N	32	W	36	80	3	U	215/...
1	2	3	4	5	6	7	8	9	10	11
1 - Product Line GMG - Gear Milling	2 - Holder Type E - End Mill	3 - No. of Flutes 5	4 - Clamping N - Stopper S - Screw	5 - Shank Diameter 25, 32	6 - Shank Style W - Weldon Shank	7 - Cutting Diameter [mm] 32, 36	8 - Toolholder Overhang 50 - 80	9 - Insert Size (IC) 2 - IC 1/4" 3 - IC 3/8"	10 - Insert Style U - U Style	11 - Special Holder No. 215/... None - Standard Holder

Gear Milling Holders (Shell Mill and Disc Mill)

GMG	S	5	S	D85	27	4	U	T	215/...
1	2	3	4	5	6	7	8	9	10
1 - Product Line GMG - Gear Milling	2 - Holder Type S - Shell Mill D - Disc Mill	3 - No. of Flutes 3 - 12	4 - Clamping N - Stopper S - Screw	5 - Cutting Diameter [mm] 42 - 90	6 - Drive Hole Diameter [mm] 22, 27	7 - Insert Size 2 - IC1/4" 3 - IC 3/8" 4 - IC 1/2" 5 - IC5/8"	8 - Insert Style U - U Style	9 - No. of Cutting Edges T - Single None - 3	10 - Special Holder No. 215/... None - Standard Holder

Tailor-Made Inserts for Gear, Spline and Rack Applications

External

Circular Pitch

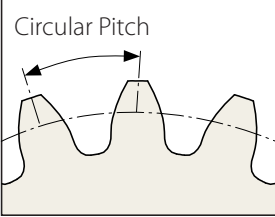

Module = Pitch / π
DP = 25.4 / Module

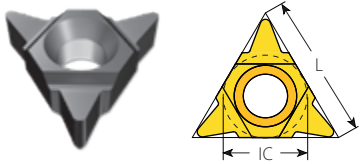

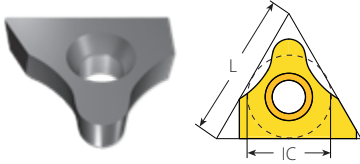

U Style -
3 Cutting Edges



UT Style -
1 Cutting Edge

Based on the required customer application, VARDEX designs and supplies tailor-made inserts to suit a **specific Module / DP** as well as the exact number of teeth used on the component.

Tailor-made Inserts for Gear, Spline and Rack Applications

Application	Module	Diametral Pitch (DP)	Insert Size	L	Cutting Edges	Toolholder	Page	
 Gear  Rack	0.5-1.0	26-52	1/4"U	11	3	GMGE5N25W32-50-2U GMD12ND85-22-2U	14 20	
	1.0-1.5	17-26	3/8"U	16	3	GMGE5N32W36-80-3U	14	
						GMGS6ND42-16-3U	15	
		1.75-2.0	13-16	1/2"U	22	3	GMGS7ND48-22-3U	15
							GMD12ND90-22-3U	20
		3.0-3.5	7.5-9	1/2"UT	22	1	GMGS4SD52-22-4U	16
GMGS7ND70-27-4U							16	
2.25-2.75	9.5-12	5/8"U	27	3	GMGS6SD85-27-4UT	17		
					GMGS3SD60-22-5U	18		
3.5-6	4.5-7	5/8"UT	27	1	GMGS6ND80-27-5U	18		
 Spline	0.5-1.25	48/96; 40/80; 32/64; 24/48	1/4"U	11	3	GMGE5N25W32-50-2U GMD12ND85-22-2U	14 20	
	1.5-2.0	20/40; 16/32	3/8"U	16	3	GMGE5N32W36-80-3U	14	
						GMGS6ND42-16-3U	15	
						GMGS7ND48-22-3U	15	
	2.0-3.0	12/24; 10/20	1/2"U	22	3	GMD12ND90-22-3U	20	
						GMGS4SD52-22-4U	16	
	4.0-5.0	6/12; 5/10; 8/16	1/2"UT	22	1	GMGS7ND70-27-4U	16	
GMGS6SD85-27-4UT						17		
GMGS3SD60-22-5U						18		
3.0-4.0	8/16; 6/12	5/8"U	27	3	GMGS6ND80-27-5U	18		
					GMGS5SD80-27-5UT	19		
5.0-8.0	5/10; 4/8	5/8"UT	27	1				

Standard DIN 3972 Inserts for Gear Applications

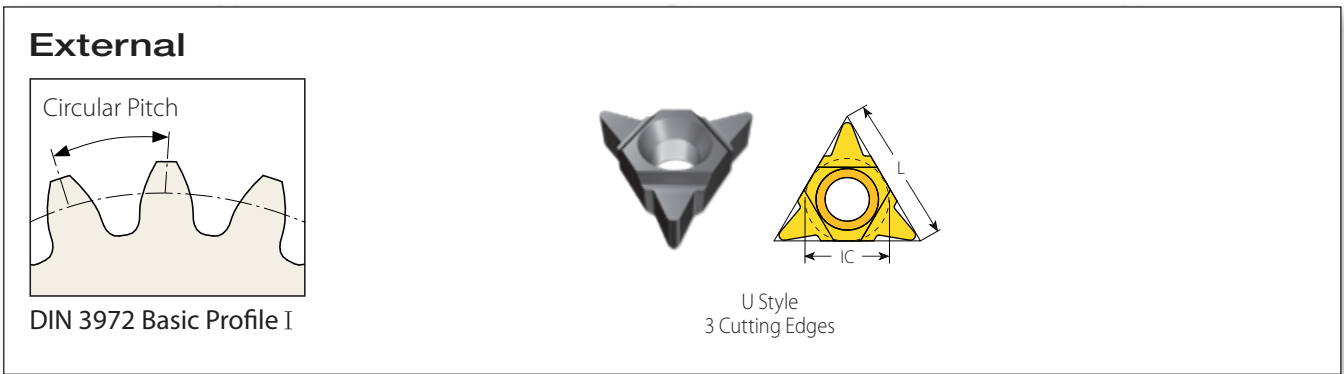

According to Standard DIN 3972 Basic Profile 1, tolerance class 11, there are 4 different modules available: 1.0, 1.5, 2.0, 2.5. For each module, there are 8 different types of inserts to select, according to the number of teeth on the gear.

Standard Inserts for Gear Applications

IC	L mm	Module	Ordering Code	Milling Cutter No.	Z - Range of Teeth on Gear	Toolholder	Page
3/8"U	16	1	3UEM1.0Z12-13N1GM...	N1	12-13	GMGE5N32W36-80-3U GMGS6ND42-16-3U GMGS7ND48-22-3U GMGD12ND90-22-3U	14 15 15 20
			3UEM1.0Z14-16N2GM...	N2	14-16		
			3UEM1.0Z17-20N3GM...	N3	17-20		
			3UEM1.0Z21-25N4GM...	N4	21-25		
			3UEM1.0Z26-34N5GM...	N5	26-34		
			3UEM1.0Z35-54N6GM...	N6	35-54		
			3UEM1.0Z55-134N7GM...	N7	55-134		
			3UEM1.0Z135N8GM...	N8	135 and up		
3/8"U	16	1.5	3UEM1.5Z12-13N1GM...	N1	12-13	GMGE5N32W36-80-3U GMGS6ND42-16-3U GMGS7ND48-22-3U GMGD12ND90-22-3U	14 15 15 20
			3UEM1.5Z14-16N2GM...	N2	14-16		
			3UEM1.5Z17-20N3GM...	N3	17-20		
			3UEM1.5Z21-25N4GM...	N4	21-25		
			3UEM1.5Z26-34N5GM...	N5	26-34		
			3UEM1.5Z35-54N6GM...	N6	35-54		
			3UEM1.5Z55-134N7GM...	N7	55-134		
			3UEM1.5Z135N8GM...	N8	135 and up		
1/2"U	22	2	4UEM2.0Z12-13N1GM...	N1	12-13	GMGS4SD52-22-4U GMGS7ND70-27-4U	16 16
			4UEM2.0Z14-16N2GM...	N2	14-16		
			4UEM2.0Z17-20N3GM...	N3	17-20		
			4UEM2.0Z21-25N4GM...	N4	21-25		
			4UEM2.0Z26-34N5GM...	N5	26-34		
			4UEM2.0Z35-54N6GM...	N6	35-54		
			4UEM2.0Z55-134N7GM...	N7	55-134		
			4UEM2.0Z135N8GM...	N8	135 and up		
5/8"U	27	2.5	5UEM2.5Z12-13N1GM...	N1	12-13	GMGS3SD60-22-5U GMGS6ND80-27-5U	18 18
			5UEM2.5Z14-16N2GM...	N2	14-16		
			5UEM2.5Z17-20N3GM...	N3	17-20		
			5UEM2.5Z21-25N4GM...	N4	21-25		
			5UEM2.5Z26-34N5GM...	N5	26-34		
			5UEM2.5Z35-54N6GM...	N6	35-54		
			5UEM2.5Z55-134N7GM...	N7	55-134		
			5UEM2.5Z135N8GM...	N8	135 and up		

Standard DIN 5480 Inserts for Spline Applications

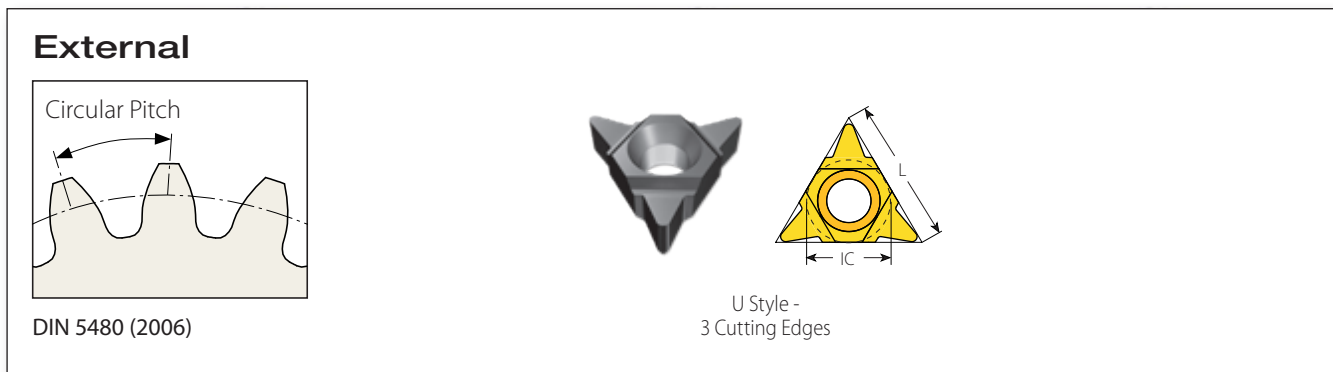

According to Standard DIN 5480 (2006), there are 10 different modules available: 0.8, 1, 1.25, 1.5, 2, 2.5, 3, 4, 5, and 6. For each module, there are different types of inserts to select, according to the number of teeth on the spline.

Standard Inserts for Spline Applications

IC	L mm	Module	Ordering Code	W - Reference Diameter mm	Z - Range of Teeth on Spline	Generic Toolholder	Page
1/4"U	11	0.8	2UEW15M0.8Z17-5480GM...	15	17	GMGE5N25W32-50-2U GMGD12ND85-22-2U	14 20
			2UEW17M0.8Z20-5480GM...	17	20		
			2UEW18M0.8Z21-5480GM...	18	21		
			2UEW20M0.8Z24-5480 GM...	20	24		
			2UEW25M0.8Z30-5480 GM...	25	30		
			2UEW45M0.8Z55-5480 GM...	45	55		
1/4"U	11	1	2UEW15M1.0Z13-5480GM...	15	13	GMGE5N25W32-50-2U GMGD12ND85-22-2U	14 20
			2UEW16M1.0Z14-5480GM...	16	14		
			2UEW18M1.0Z16-5480GM...	18	16		
			2UEW23M1.0Z22-5480GM...	23	22		
			2UEW24M1.0Z22-5480GM...	24	22		
			2UEW25M1.0Z24-5480GM...	25	24		
			2UEW28M1.0Z26-5480GM...	28	26		
			2UEW30M1.0Z28-5480GM...	30	28		
			2UEW34M1.0Z32-5480GM...	34	32		
2UEW37M1.0Z36-5480GM...	37	36					
3/8"U	16	1.25	3UEW20M1.25Z14-5480GM...	20	14	GMGE5N32W36-80-3U GMGS6ND42-16-3U GMGS7ND48-22-3U GMGD12ND90-22-3U	14 15 15 20
			3UEW22M1.25Z16-5480GM...	22	16		
			3UEW25M1.25Z18-5480GM...	25	18		
			3UEW28M1.25Z21-5480GM...	28	21		
			3UEW30M1.25Z22-5480GM...	30	22		
			3UEW32M1.25Z24-5480GM...	32	24		
			3UEW35M1.25Z26-5480GM...	35	26		
			3UEW38M1.25Z29-5480GM...	38	29		
			3UEW42M1.25Z32-5480GM...	42	32		
			3UEW45M1.25Z34-5480GM...	45	34		
			3UEW55M1.25Z42-5480GM...	55	42		

Standard DIN 5480 Inserts for Spline Applications (con't)

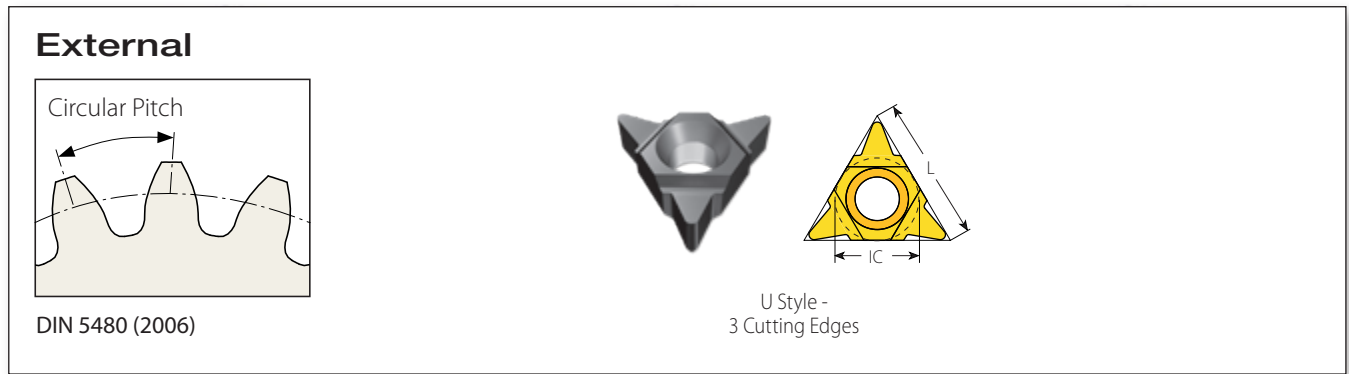

Standard Inserts for Spline Applications

IC	L mm	Module	Ordering Code	W - Reference Diameter mm	Z - Range of Teeth on Spline	Generic Toolholder	Page
3/8"U	16	1.5	3UEW22M1.5Z13-5480GM...	22	13	GMGE5N32W36-80-3U GMGS6ND42-16-3U GMGS7ND48-22-3U GMGD12ND90-22-3U	14 15 15 20
			3UEW27M1.5Z16-5480GM...	27	16		
			3UEW29M1.5Z18-5480 GM...	29	18		
			3UEW30M1.5Z18-5480 GM...	30	18		
			3UEW35M1.5Z22-5480GM...	35	22		
			3UEW38M1.5Z24-5480GM...	38	24		
			3UEW40M1.5Z25-5480GM...	40	25		
			3UEW42M1.5Z26-5480GM...	42	26		
			3UEW45M1.5Z28-5480GM...	45	28		
			3UEW50M1.5Z32-5480GM...	50	32		
			3UEW52M1.5Z33-5480GM...	52	33		
			3UEW55M1.5Z35-5480GM...	55	35		
			3UEW65M1.5Z42-5480GM...	65	42		
3UEW95M1.5Z62-5480GM...	95	62					
3/8"U	16	2	3UEW25M2.0Z11-5480GM...	25	11	GMGE5N32W36-80-3U GMGS6ND42-16-3U GMGS7ND48-22-3U GMGD12ND90-22-3U	14 15 15 20
			3UEW30M2.0Z13-5480GM...	30	13		
			3UEW32M2.0Z14-5480GM...	32	14		
			3UEW35M2.0Z16-5480GM...	35	16		
			3UEW37M2.0Z17-5480GM...	37	17		
			3UEW40M2.0Z18-5480GM...	40	18		
			3UEW42M2.0Z20-5480GM...	42	20		
			3UEW45M2.0Z21-5480GM...	45	21		
			3UEW48M2.0Z22-5480GM...	48	22		
			3UEW50M2.0Z24-5480GM...	50	24		
			3UEW55M2.0Z26-5480GM...	55	26		
			3UEW60M2.0Z28-5480GM...	60	28		
			3UEW62M2.0Z30-5480GM...	62	30		
			3UEW65M2.0Z31-5480GM...	65	31		
			3UEW68M2.0Z32-5480GM...	68	32		
			3UEW70M2.0Z34-5480GM...	70	34		
			3UEW75M2.0Z36-5480GM...	75	36		
			3UEW80M2.0Z38-5480GM...	80	38		
			3UEW85M2.0Z41-5480GM...	85	41		
			3UEW95M2.0Z46-5480GM...	95	46		
3UEW105M2.0Z51-5480GM...	105	51					
3UEW130M2.0Z64-5480GM...	130	64					

ТОВ «СМАРТТЕК ІНЖИНІРИНГ», Т. +380-50-396-90-96, info@smarttec.com.ua, https://www.smarttec.com.ua

Standard DIN 5480 Inserts for Spline Applications (con't)

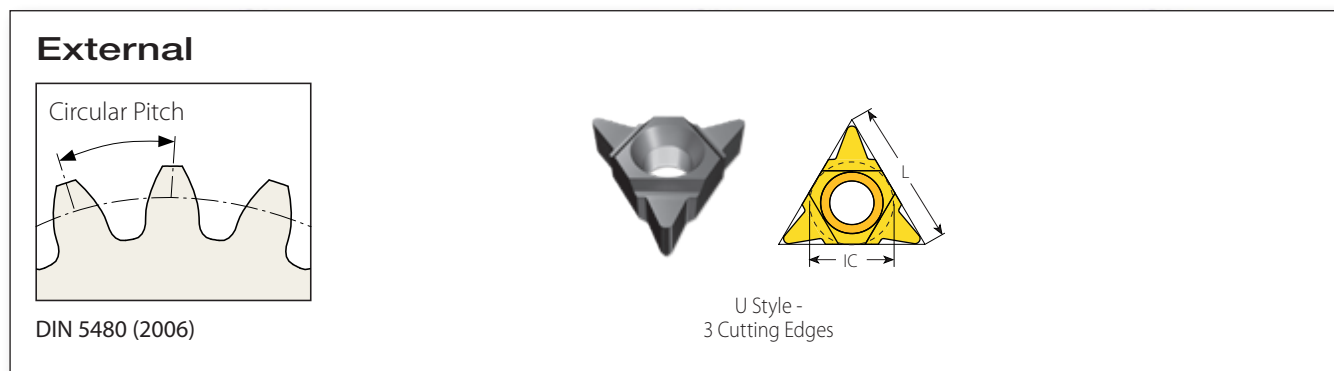

Standard Inserts for Spline Applications

IC	L mm	Module	Ordering Code	W - Reference Diameter mm	Z - Range of Teeth on Spline	Generic Toolholder	Page
1/2"U	22	2.5	4UEW35M2.5Z12-5480GM...	35	12	GMGS4SD52-22-4U GMGS7ND70-27-4U	16 16
			4UEW40M2.5Z14-5480GM...	40	14		
			4UEW45M2.5Z16-5480GM...	45	16		
			4UEW50M2.5Z18-5480GM...	50	18		
			4UEW60M2.5Z22-5480GM...	60	22		
			4UEW70M2.5Z26-5480GM...	70	26		
			4UEW75M2.5Z28-5480GM...	75	28		
			4UEW80M2.5Z30-5480GM...	80	30		
			4UEW85M2.5Z32-5480GM...	85	32		
			4UEW98M2.5Z38-5480GM...	98	38		
4UEW120M2.5Z46-5480GM...	120	46					
5/8"U	27	3	5UEW48M3.0Z14-5480GM...	40	14	GMGS3SD60-22-5U GMGS6ND80-27-5U	18 18
			5UEW50M3.0Z15-5480GM...	50	15		
			5UEW52M3.0Z16-5480GM...	52	16		
			5UEW55M3.0Z17-5480GM...	55	17		
			5UEW60M3.0Z18-5480GM...	60	18		
			5UEW65M3.0Z20-5480GM...	65	20		
			5UEW70M3.0Z22-5480GM...	70	22		
			5UEW75M3.0Z24-5480GM...	75	24		
			5UEW80M3.0Z25-5480GM...	80	25		
			5UEW85M3.0Z27-5480GM...	85	27		
			5UEW90M3.0Z28-5480GM...	90	28		
			5UEW95M3.0Z30-5480GM...	95	30		
			5UEW98M3.0Z31-5480GM...	98	31		
			5UEW100M3.0Z32-5480GM...	100	32		
			5UEW105M3.0Z34-5480GM...	105	34		
			5UEW110M3.0Z35-5480GM...	110	35		
			5UEW120M3.0Z38-5480GM...	120	38		
			5UEW130M3.0Z42-5480GM...	130	42		
5UEW140M3.0Z45-5480GM...	140	45					
5UEW150M3.0Z48-5480GM...	150	48					
5UEW180M3.0Z58-5480GM...	180	58					



Standard DIN 5480 Inserts for Spline Applications (con't)

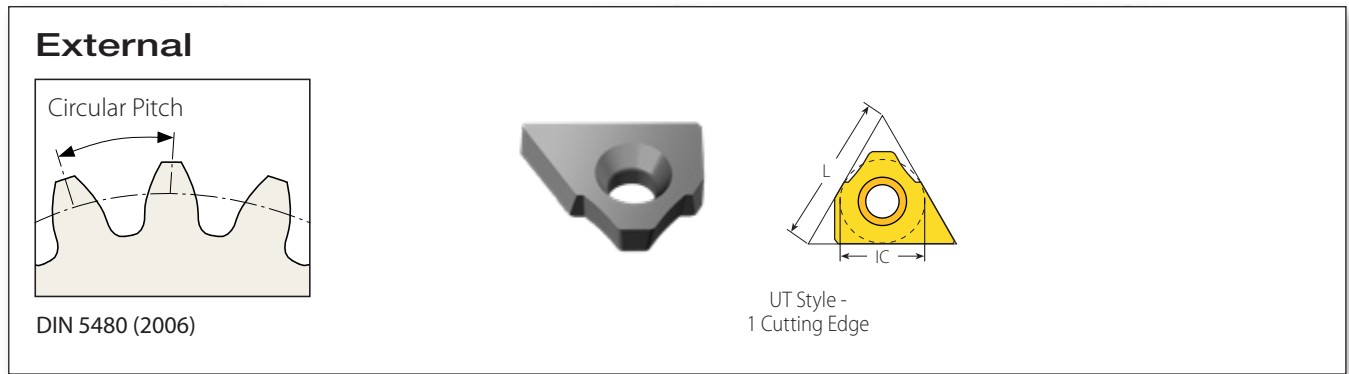

Standard Inserts for Spline Applications

IC	L mm	Module	Ordering Code	W - Reference Diameter mm	Z - Range of Teeth on Spline	Generic Toolholder	Page
1/2"UT	22	4	4UTEW50M4.0Z11-5480GM...	50	11	GMGS6SD85-27-4UT	17
			4UTEW65M4.0Z15-5480GM...	65	15		
			4UTEW70M4.0Z16-5480GM...	70	16		
			4UTEW78M4.0Z18-5480GM...	78	18		
			4UTEW88M4.0Z20-5480GM...	88	20		
			4UTEW95M4.0Z22-5480GM...	95	22		
			4UTEW120M4.0Z28-5480GM...	120	28		
			4UTEW130M4.0Z31-5480GM...	130	31		
			4UTEW140M4.0Z34-5480GM...	140	34		
			4UTEW150M4.0Z36-5480GM...	150	36		
			4UTEW160M4.0Z38-5480GM...	160	38		
			4UTEW170M4.0Z41-5480GM...	170	41		
1/2"UT	22	5	4UTEW65M5.0Z11-5480GM...	65	11	GMGS6SD85-27-4UT	17
			4UTEW110M5.0Z20-5480GM...	110	20		
			4UTEW120M5.0Z22-5480GM...	120	22		
			4UTEW130M5.0Z24-5480GM...	130	24		
			4UTEW140M5.0Z26-5480GM...	140	26		
			4UTEW150M5.0Z28-5480GM...	150	28		
			4UTEW160M5.0Z30-5480GM...	160	30		
			4UTEW280M5.0Z54-5480GM...	280	54		
			4UTEW260M5.0Z50-5480GM...	260	50		
			4UTEW180M5.0Z34-5480GM...	180	34		
			4UTEW180M5.0Z36-5480GM...	180	36		
			4UTEW190M5.0Z36-5480GM...	190	36		
			4UTEW200M5.0Z38-5480GM...	200	38		
			4UTEW210M5.0Z40-5480GM...	210	40		
			4UTEW220M5.0Z42-5480GM...	220	42		
			4UTEW240M5.0Z46-5480GM...	240	46		
			4UTEW250M5.0Z48-5480GM...	250	48		
			4UTEW320M5.0Z62-5480GM...	320	62		
5/8"UT	27	6	5UTEW105M6.0Z16-5480GM...	105	16	GMGS5SD80-27-5UT	19
			5UTEW130M6.0Z20-5480GM...	130	20		
			5UTEW140M6.0Z22-5480GM...	140	22		
			5UTEW150M6.0Z24-5480GM...	150	24		
			5UTEW200M6.0Z32-5480GM...	200	32		
			5UTEW210M6.0Z34-5480GM...	210	34		
			5UTEW220M6.0Z35-5480GM...	220	35		
			5UTEW250M6.0Z40-5480GM...	250	40		
			5UTEW320M6.0Z52-5480GM...	320	52		
			5UTEW340M6.0Z55-5480GM...	340	55		
			5UTEW360M6.0Z58-5480GM...	360	58		
			5UTEW380M6.0Z62-5480GM...	380	62		

ТОВ «СМАРТТЕК ІНЖИНІРИНГ», Т. +380-50-396-90-96, info@smarttec.com.ua, https://www.smarttec.com.ua

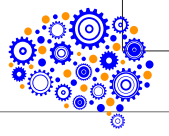

Standard ANSI B92.1 Inserts for Spline Applications

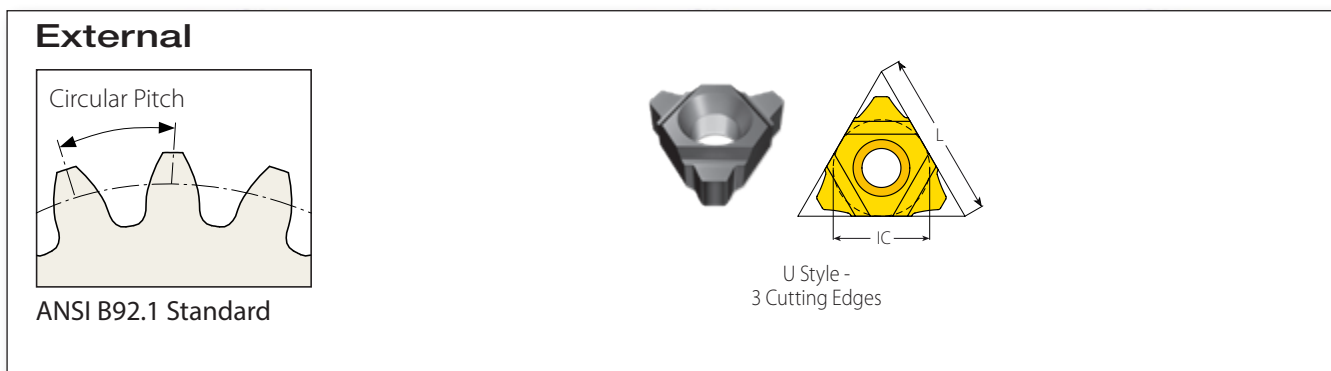

According to Standard ANSI B92.1, there are 7 different diametral pitches available, ranging: DP32/64 to DP8/16. For each DP, there are 8 different types of inserts to select, according to the number of teeth on the spline.

Standard Inserts for Spline Applications

IC	Lmm	Diametral Pitch (DP)	Ordering Code	Milling Cutter No.	Z - Range of Teeth on Gear	Toolholder	Page
1/4"U	11	DP32/64	2UEDP32/64Z10-11N1GM...	N1	10-11	GMGE5N25W32-50-2U GMGD12ND85-22-2U	14 20
			2UEDP32/64Z12-13N2GM...	N2	12-13		
			2UEDP32/64Z14-16N3GM...	N3	14-16		
			2UEDP32/64Z17-20N4GM...	N4	17-20		
			2UEDP32/64Z21-25N5GM...	N5	21-25		
			2UEDP32/64Z26-34N6GM...	N6	26-34		
			2UEDP32/64Z35-54N7GM...	N7	35-54		
			2UEDP32/64Z55-135N8GM...	N8	55-135		
		DP24/48	2UEDP24/48Z10-11N1GM...	N1	10-11		
			2UEDP24/48Z12-13N2GM...	N2	12-13		
			2UEDP24/48Z14-16N3GM...	N3	14-16		
			2UEDP24/48Z17-20N4GM...	N4	17-20		
			2UEDP24/48Z21-25N5GM...	N5	21-25		
			2UEDP24/48Z26-34N6GM...	N6	26-34		
			2UEDP24/48Z35-54N7GM...	N7	35-54		
			2UEDP24/48Z55-135N8GM...	N8	55-135		
3/8"U	16	DP20/40	3UEDP20/40Z10-11N1GM...	N1	10-11	GMGE5N32W36-80-3U GMGS6ND42-16-3U GMGS7ND48-22-3U GMGD12ND90-22-3U	14 15 15 20
			3UEDP20/40Z12-13N2GM...	N2	12-13		
			3UEDP20/40Z14-16N3GM...	N3	14-16		
			3UEDP20/40Z17-20N4GM...	N4	17-20		
			3UEDP20/40Z21-25N5GM...	N5	21-25		
			3UEDP20/40Z26-34N6GM...	N6	26-34		
			3UEDP20/40Z35-54N7GM...	N7	35-54		
			3UEDP20/40Z55-135N8GM...	N8	55-135		
		DP16/32	3UEDP16/32Z10-11N1GM...	N1	10-11		
			3UEDP16/32Z12-13N2GM...	N2	12-13		
			3UEDP16/32Z14-16N3GM...	N3	14-16		
			3UEDP16/32Z17-20N4GM...	N4	17-20		
			3UEDP16/32Z21-25N5GM...	N5	21-25		
			3UEDP16/32Z26-34N6GM...	N6	26-34		
			3UEDP16/32Z35-54N7GM...	N7	35-54		
			3UEDP16/32Z55-135N8GM...	N8	55-135		



Standard ANSI B92.1 Inserts for Spline Applications (con't)

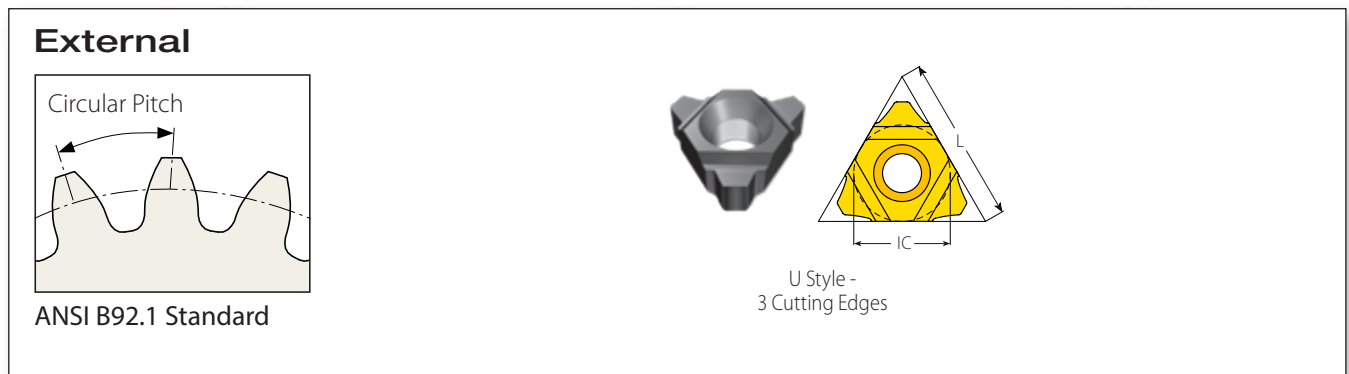

Standard Inserts for Spline Applications

IC	L mm	Diametral Pitch (DP)	Ordering Code	Milling Cutter No.	Z - Range of Teeth on Gear	Toolholder	Page
1/2"U	22	DP12/24	4UEDP12/24Z10-11N1GM...	N1	10-11	GMGS4S D52-22-4U GMGS7N D70-27-4U	16
			4UEDP12/24Z12-13N2GM...	N2	12-13		
			4UEDP12/24Z14-16N3GM...	N3	14-16		
			4UEDP12/24Z17-20N4GM...	N4	17-20		
			4UEDP12/24Z21-25N5GM...	N5	21-25		
			4UEDP12/24Z26-34N6GM...	N6	26-34		
			4UEDP12/24Z35-54N7GM...	N7	35-54		
			4UEDP12/24Z55-135N8GM...	N8	55-135		
		DP10/20	4UEDP10/20Z10-11N1GM...	N1	10-11		
			4UEDP10/20Z12-13N2GM...	N2	12-13		
			4UEDP10/20Z14-16N3GM...	N3	14-16		
			4UEDP10/20Z17-20N4GM...	N4	17-20		
			4UEDP10/20Z21-25N5GM...	N5	21-25		
			4UEDP10/20Z26-34N6GM...	N6	26-34		
			4UEDP10/20Z35-54N7GM...	N7	35-54		
			4UEDP10/20Z55-135N8GM...	N8	55-135		
5/8"U	27	DP8/16	5UEDP8/16Z10-11N1GM...	N1	10-11	GMGS3SD60-22-5U GMGS6ND80-27-5U	18
			5UEDP8/16Z12-13N2GM...	N2	12-13		
			5UEDP8/16Z14-16N3GM...	N3	14-16		
			5UEDP8/16Z17-20N4GM...	N4	17-20		
			5UEDP8/16Z21-25N5GM...	N5	21-25		
			5UEDP8/16Z26-34N6GM...	N6	26-34		
			5UEDP8/16Z35-54N7GM...	N7	35-54		
			5UEDP8/16Z55-135N8GM...	N8	55-135		

Standard Toolholder - Weldon Shank for IC 1/4"U

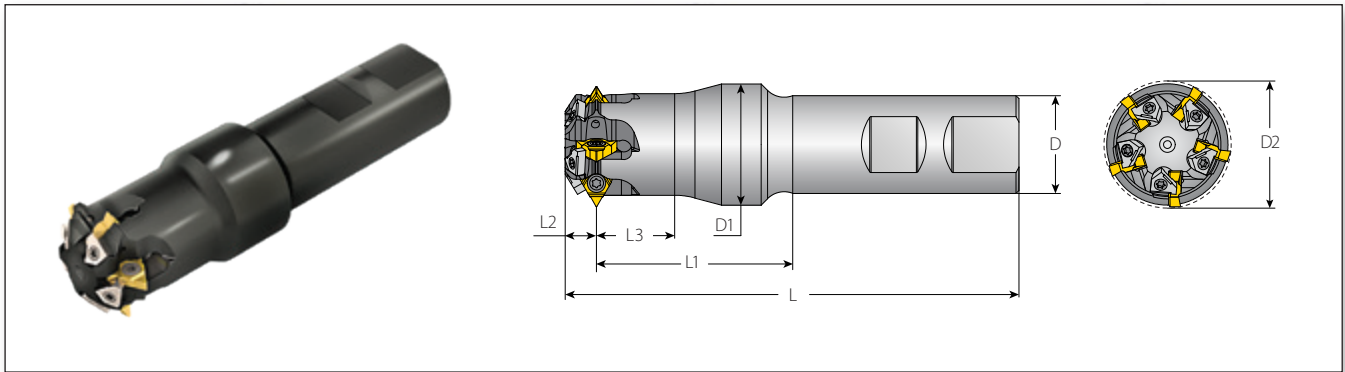

For Gear, Rack and Spline Inserts

Insert Size	Insert Cutting Edges	Ordering Code	Dimensions (mm)								No. of Flutes	Spare Parts			
			L	L1	L3	D	D1	*D2 (ref)	L2	Z		Insert Screw	Insert Torx+ Key	Stopper	Stopper Screw
1/4"U	3	GMGE5N25W32-50-2U	116	50	20	25	31	32	8.0	5	SN2T	HK2T	5LST	SN5LTR	K7T

* D2 refers to the mounted insert. Check D2 before machining.

Standard Toolholder - Weldon Shank for IC 3/8"U

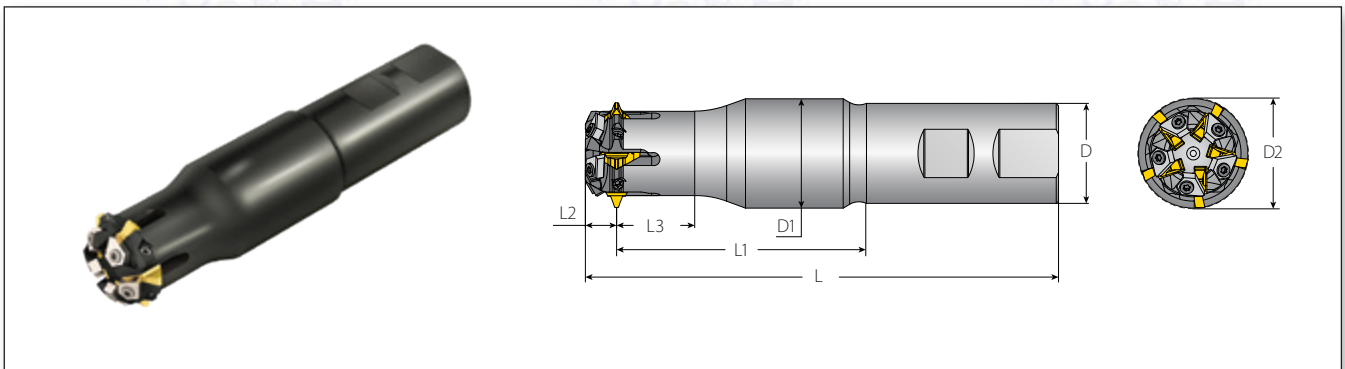

For Gear, Rack and Spline Inserts

Insert Size	Insert Cutting Edges	Ordering Code	Dimensions (mm)								No. of Flutes	Spare Parts			
			L	L1	L3	D	D1	*D2 (ref)	L2	Z		Insert Screw	Insert Torx+ Key	Stopper	Stopper Screw
3/8"U	3	GMGE5N32W36-80-3U	151	80	25	32	35	36	10.0	5	SR3FIP8	KIP8	2TM1ST	M3x7.5	KIP8

* D2 refers to the mounted insert. Check D2 before machining.

Standard Toolholder - Shell Mill for IC 3/8"U

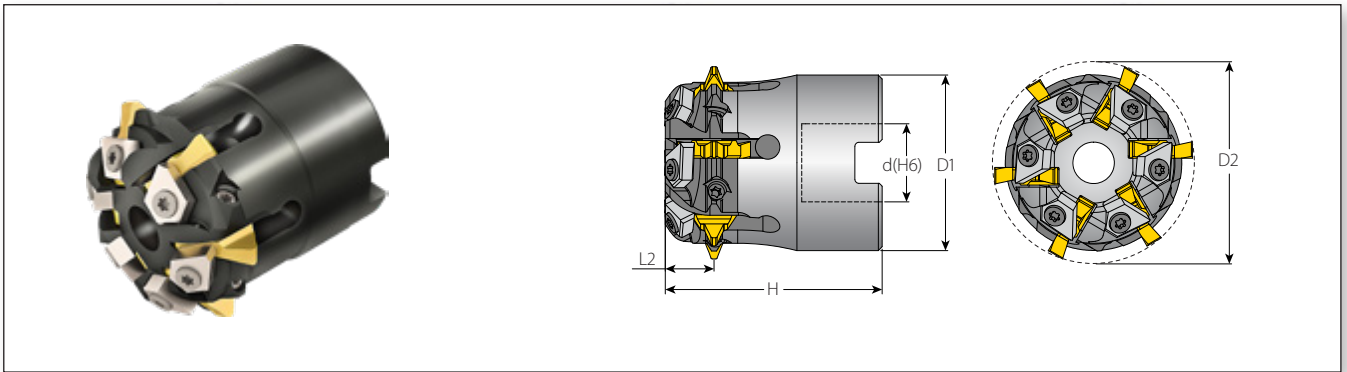

For Gear, Rack and Spline Inserts

Insert Size	Insert Cutting Edges	Ordering Code	Dimensions (mm)						No. of Flutes	Spare Parts				
			D1	*D2 (ref)	d (H6)	H	L2	Z		Insert Screw	Insert Torx+ Key	Stopper	Stopper Screw	Stopper Key
3/8"U	3	GMGS6ND42-16-3U	36	42	16	44.5	10.0	6	SR3FIP8	KIP8	2TM1ST	M3x7.5	KIP8	M8x1.25x40

* D2 refers to the mounted insert. Check D2 before machining.

Standard Toolholder - Shell Mill for IC 3/8"U

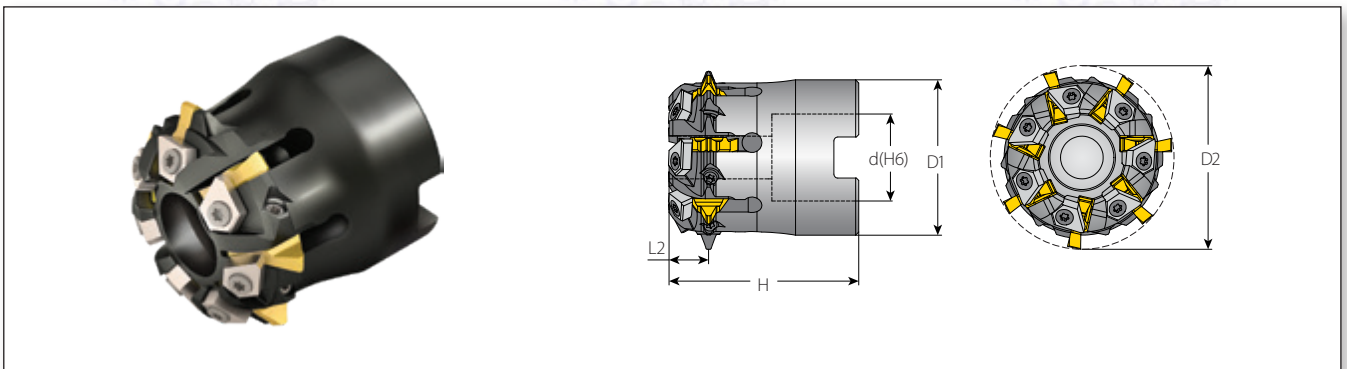

For Gear, Rack and Spline Inserts

Insert Size	Insert Cutting Edges	Ordering Code	Dimensions (mm)						No. of Flutes	Spare Parts				
			D1	*D2 (ref)	d (H6)	H	L2	Z		Insert Screw	Insert Torx+ Key	Stopper	Stopper Screw	Stopper Key
3/8"U	3	GMGS7ND48-22-3U	39.3	48	22	48	10.0	7	SR3FIP8	KIP8	2TM1ST	M3x7.5	KIP8	M10x1.5x40

* D2 refers to the mounted insert. Check D2 before machining.

Standard Toolholder - Shell Mill for IC 1/2"U

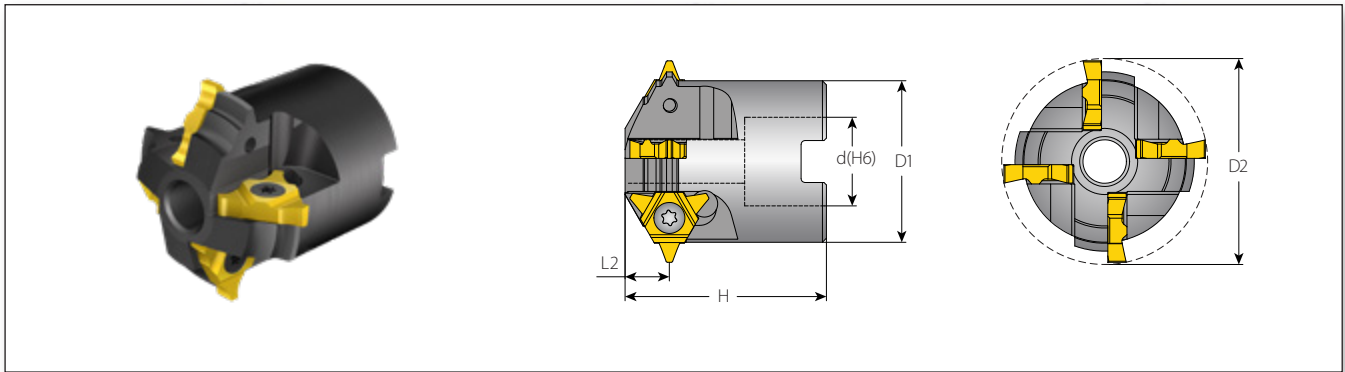

For Gear, Rack and Spline Inserts

Insert Size	Insert Cutting Edges	Ordering Code	Dimensions (mm)						No. of Flutes	Spare Parts		
			D1	*D2 (ref)	d (H6)	H	L2	Z		Insert Screw	Insert Torx Key	Holder Screw
1/2"U	3	GMGS4S D52-22-4U	40	52	22	50	11	4	SN4T	HK4T	M10x1.5x50	

* D2 refers to the mounted insert. Check D2 before machining.

Standard Toolholder - Shell Mill for IC 1/2"U

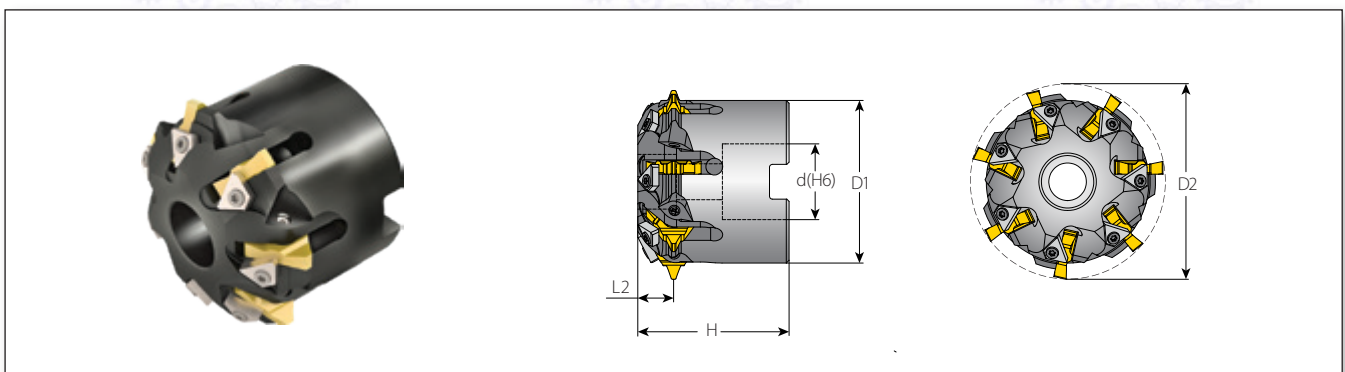

For Gear, Rack and Spline Inserts

Insert Size	Insert Cutting Edges	Ordering Code	Dimensions (mm)						No. of Flutes	Spare Parts				
			D1	*D2 (ref)	d (H6)	H	L2	Z		Insert Screw	Insert Torx+ Key	Stopper	Stopper Screw	Stopper Key
1/2"U	3	GMGS7N D70-27-4U	58	70	27	54	12.8	7	SR3FIP8	KIP8	2TM2ST	M3x7.5	KIP8	M12x1.75x40

* D2 refers to the mounted insert. Check D2 before machining.

Standard Toolholder - Shell Mill for IC 1/2"UT

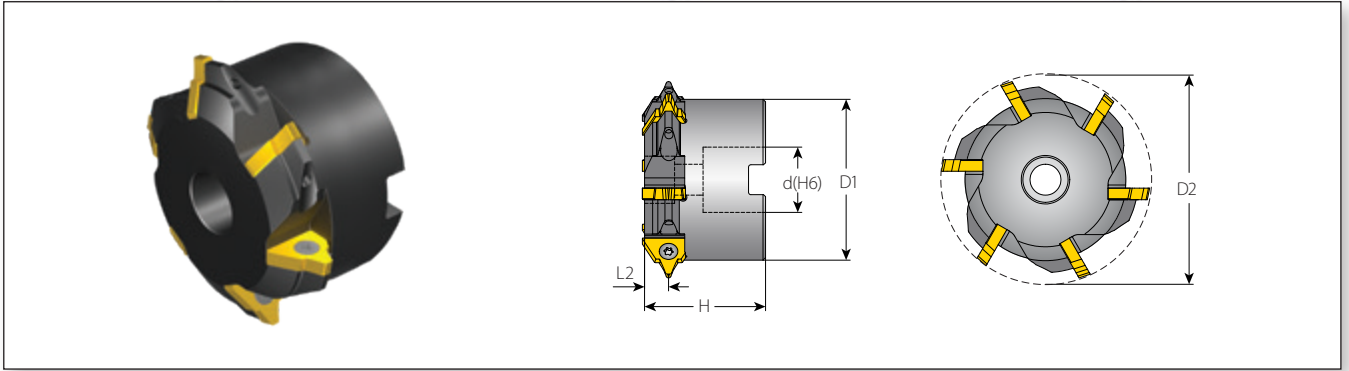

For Gear, Rack and Spline Inserts

Insert Size	Insert Cutting Edges	Ordering Code	Dimensions (mm)						No. of Flutes	Spare Parts		
			D1	*D2 (ref)	d (H6)	H	L2	Z		Insert Screw	Insert Torx Key	Holder Screw
IC												
1/2"UT	1	GMGS6SD85-27-4UT	66.5	85	27	50	9.9	6	SN4T	Ballpoint T20	M12x1.75x40	

* D2 refers to the mounted insert. Check D2 before machining.

Standard Toolholder - Shell Mill for IC 5/8"U

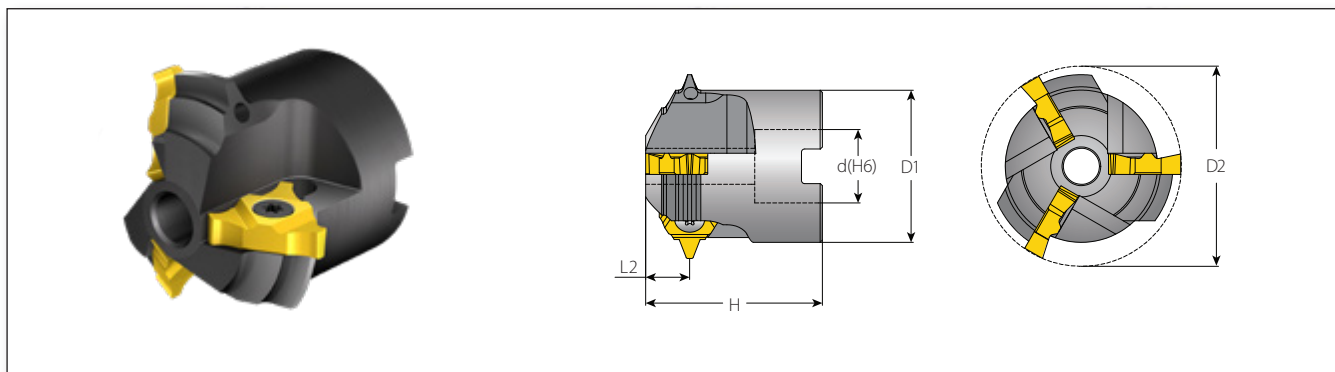

For Gear, Rack and Spline Inserts

Insert Size	Insert Cutting Edges	Ordering Code	Dimensions (mm)						No. of Flutes	Spare Parts		
			D1	*D2 (ref)	d (H6)	H	L2	Z		Insert Screw	Insert Torx Key	Holder Screw
5/8"U	3	GMGS3SD60-22-5U	45.6	60	22	53	13.2	3	SN5TM	HK5T	M10x1.5x55	

* D2 refers to the mounted insert. Check D2 before machining.

Standard Toolholder - Shell Mill for IC 5/8"U

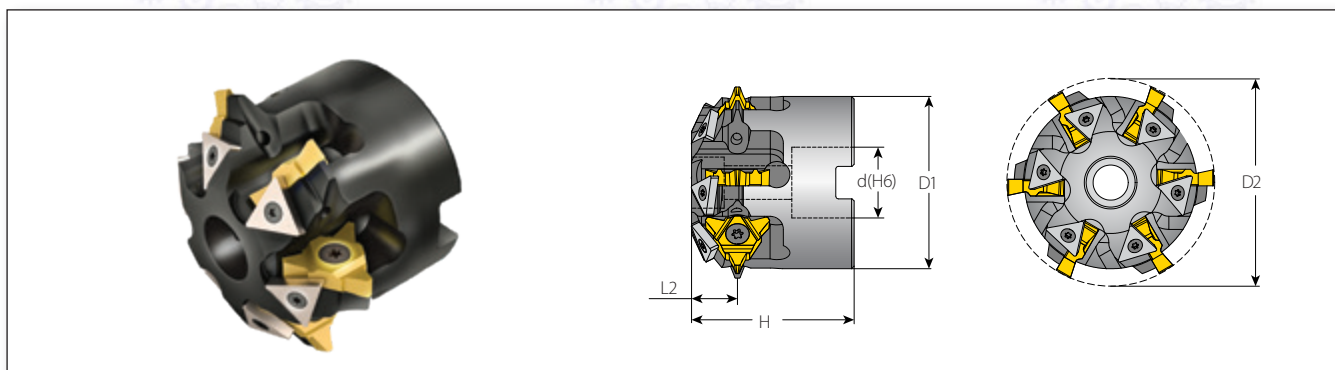

For Gear, Rack and Spline Inserts



Insert Size	Insert Cutting Edges	Ordering Code	Dimensions (mm)						No. of Flutes	Spare Parts				
			D1	*D2 (ref)	d (H6)	H	L2	Z		Insert Screw	Insert Torx Key	Stopper	Stopper Screw	Stopper Key
5/8"U	3	GMGS6ND80-27-5U	65.7	80	27	62	17.5	6	SN5TM	HK5T	3ST	SN3TM	K3T	M12x1.75x50

* D2 refers to the mounted insert. Check D2 before machining.

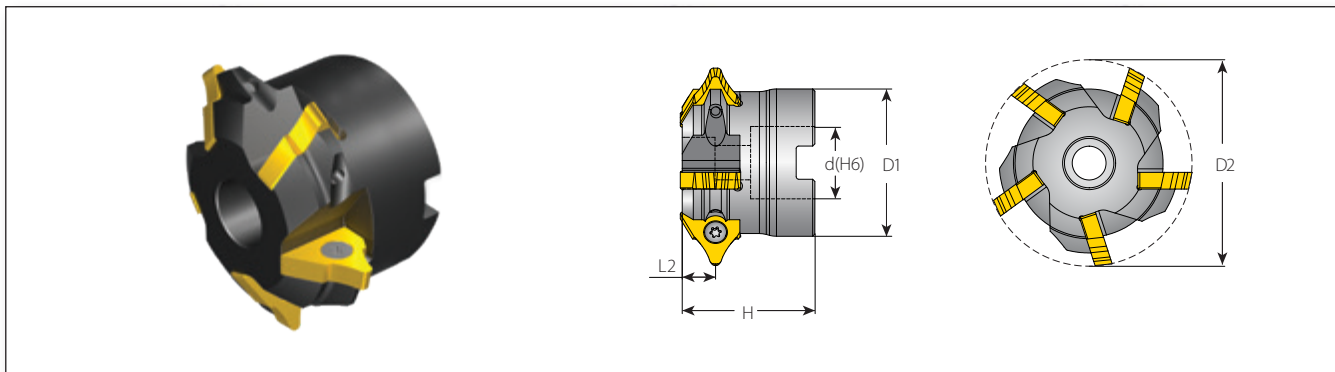
Standard Toolholder - Shell Mill for IC 5/8"UT



For Gear, Rack and Spline Solid Carbide Tools

Insert Size	Insert Cutting Edges	Ordering Code	Dimensions (mm)						No. of Flutes	Spare Parts		
			D1	*D2 (ref)	d (H6)	H	L2	Z				
IC												
5/8"UT	1	GMGS5SD80-27-5UT	55	80	27	50	12.6	5	SN5TM	Ballpoint T25	M12x1.75x40	

* D2 refers to the mounted insert. Check D2 before machining.

Standard Gear Milling Toolholder - Disc Mill for IC 1/4"U

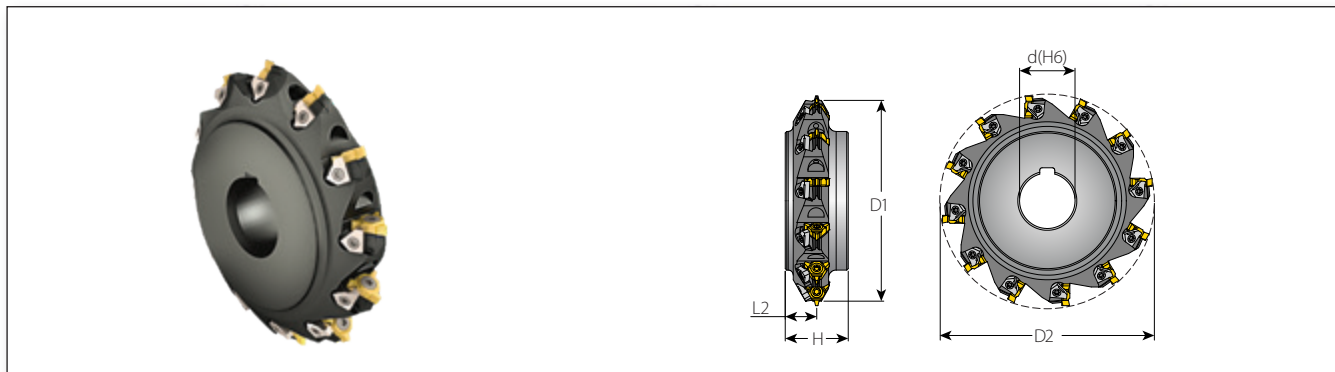

For Gear, Rack and Spline Inserts

Insert Size	Insert Cutting Edges	Ordering Code	Dimensions (mm)						No. of Flutes	Spare Parts				
			D1	*D2 (ref)	d (H6)	H	L2	Z		Insert Screw	Insert Torx Key	Stopper	Stopper Screw	Stopper Key
IC	3	GMD12ND85-22-2U	79.6	85	22	25	12.5	12	SN2T	HK2T	5LST	SN5LTR	K7T	

* D2 refers to the mounted insert. Check D2 before machining.

Standard Gear Milling Toolholder - Disc Mill for IC 3/8"U

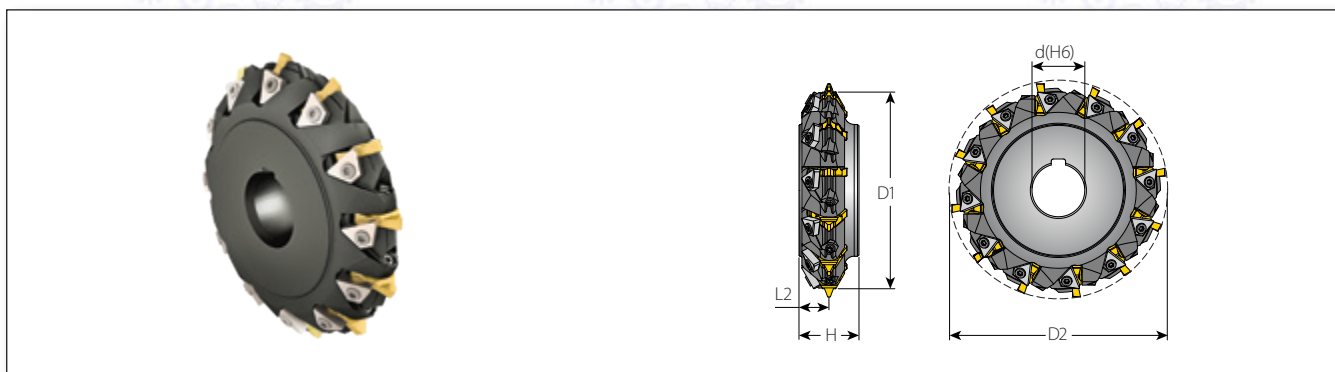

For Gear, Rack and Spline Inserts

Insert Size	Insert Cutting Edges	Ordering Code	Dimensions (mm)						No. of Flutes	Spare Parts				
			D1	*D2 (ref)	d (H6)	H	L2	Z		Insert Screw	Insert Torx+ Key	Stopper	Stopper Screw	Stopper Key
IC	3	GMD12ND90-22-3U	82	90	22	25	12.5	12	SR3FIP8	KIP8	2TM2ST	M3x7.5	KIP8	

* D2 refers to the mounted insert. Check D2 before machining.

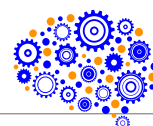

Tailor-Made Solid Carbide Gear Milling

External

Circular Pitch

Module = Pitch / π
DP = 25.4 / Module

Solid Carbide Tool Benefits

Small Tool Cutting Diameter

- Excellent solution for applications that require cutting close to the shoulder
- High RPM and fast feed

Solid Carbide Tool

- Guarantees higher accuracy

Multi-flute Tool

- Enables fast machining

Tool Range

- Cutting Diameter Range: 5.9-19.9mm (.17"-.75")
- Module: 0.5-3.0



For Tailor-Made Gear, Rack and Spline Inserts



Shank Diameter	Gear & Rack Module Range, Max			Spline Module Range, Max	
	D mm	Module	Diametral Pitch (DP)	Module	Diametral Pitch (DP)
6	0.5	DP52	0.8	DP40/80	
8	0.6	DP44	1.0	DP32/64	
10	0.8	DP32	1.25	DP24/48	
12	1.0	DP26	1.5	DP20/40	
14	1.25	DP22	1.75	DP16/32	
16	1.5	DP18	2.0	DP12/24	
18	1.75	DP15	2.5	DP10/20	
20	2.0	DP13	3.0	DP8/16	

ТОВ «СМАРТТЕК ІНЖИНІРИНГ», Т. +380-50-396-90-96, info@smarttec.com.ua, https://www.smarttec.com.ua

Recommended Grades, Cutting Speeds Vc [m/min] and Feed f [mm/tooth]

Material Group	Vardex No.	Material		Hardness Brinell HB	Indexable Inserts		Solid Carbide	
					Vc [m/min]	Feed f [mm/tooth]	Vc [m/min]	Feed f [mm/tooth]
					VBX / VTX		VTH	
P Steel	1	Unalloyed Steel	Low Carbon (C=0.1-0.25%)	125	100-210	0.20-0.32	80-250	0.10-0.35
	2		Medium Carbon (C=0.25-0.55%)	150	100-180	0.20-0.32	80-230	0.08-0.30
	3		High Carbon (C=0.55-0.85%)	170	100-170	0.15-0.23	80-200	0.08-0.30
	4	Low Alloy Steel (alloying elements ≤5%)	Non Hardened	180	60-90	0.17-0.28	60-180	0.08-0.30
	5		Hardened	275	80-150	0.15-0.28	60-170	0.08-0.30
	6		Hardened	350	70-140	0.15-0.25	60-160	0.05-0.15
	7	High Alloy Steel (alloying elements >5%)	Annealed	200	60-130	0.15-0.22	40-100	0.10-0.24
	8		Hardened	325	70-110	0.13-0.21	30-80	0.05-0.15
	9	Cast Steel	Low Alloy (alloying elements <5%)	200	100-170	0.15-0.22	80-250	0.08-0.30
	10		High Alloy (alloying elements >5%)	225	70-120	0.12-0.22	60-170	0.05-0.15
M Stainless Steel	11	Stainless Steel Ferritic	Non Hardened	200	100-170	0.15-0.22	60-150	0.11-0.35
	12		Hardened	330	100-170	0.16-0.23	60-120	0.05-0.24
	13	Stainless Steel Austenitic	Austenitic	180	70-140	0.15-0.25	60-140	0.11-0.35
	14		Super Austenitic	200	70-140	0.12-0.20	60-130	0.11-0.35
	15	Stainless Steel Cast Ferritic	Non Hardened	200	70-140	0.16-0.24	60-160	0.11-0.35
	16		Hardened	330	70-140	0.12-0.20	60-110	0.10-0.24
	17	Stainless Steel Cast Austenitic	Austenitic	200	70-120	0.15-0.22	60-150	0.11-0.35
	18		Hardened	330	70-120	0.12-0.20	60-100	0.10-0.24
K Cast Iron	28	Malleable Cast Iron	Ferritic (short chips)	130	60-130	0.16-0.24	60-70	0.05-0.15
	29		Pearlitic (long chips)	230	60-120	0.15-0.22	60-150	0.10-0.24
	30	Grey Cast Iron	Low Tensile Strength	180	60-130	0.15-0.22	70-160	0.09-0.25
	31		High Tensile Strength	260	60-100	0.15-0.22	40-120	0.10-0.24
	32	Nodular Sg Iron	Ferritic	160	60-125	0.10-0.20	40-110	0.09-0.25
33	Pearlitic		260	50-90	0.15-0.22	40-100	0.10-0.24	
N(K) Non-Ferrous Metals	34	Aluminum Alloys Wrought	Non Aging	60	100-250	0.30-0.50	200-300	0.12-0.40
	35		Aged	100	100-180	0.28-0.50	150-250	0.10-0.32
	36	Aluminum Alloys	Cast	75	150-400	0.28-0.50	100-200	0.10-0.32
	37		Cast & Aged	90	150-280	0.25-0.40	120-220	0.10-0.30
	38	Aluminum Alloys	Cast Si 13-22%	130	80-150	0.28-0.50	200-300	0.10-0.32
	39	Copper and Copper Alloys	Brass	90	120-210	0.30-0.50	200-300	0.12-0.40
	40		Bronze And Non Leaded Copper	100	120-210	0.28-0.50	150-250	0.10-0.32
S(M) Heat Resistant Material	19	High Temperature Alloys	Annealed (iron based)	200	20-45	0.09-0.15	30-60	0.11-0.35
	20		Aged (iron based)	280	20-30	0.07-0.13	20-50	0.05-0.15
	21		Annealed (nickel or cobalt based)	250	15-20	0.08-0.15	15-35	0.05-0.15
	22		Aged (nickel or cobalt based)	350	10-15	0.08-0.15	15-30	0.05-0.15
	23	Titanium Alloys	Pure 99.5 Ti	400Rm	70-140	0.07-0.13	40-80	0.10-0.24
24	α+β alloys		1050Rm	20-50	0.07-0.13	20-50	0.10-0.24	
H(K) Hardened Material	25	Extra Hard Steel	Hardened & Tempered	45-50HRC	15-45	0.05-0.12	15-45	0.025-0.06
	26			51-60HRC*	15-40	0.05-0.12	15-40	0.025-0.06

* Note: Special tools, which are not listed in this catalog, are required for extra hard steel (51-60HRC).

	Grade	Application	Sample
Indexable Insert	VBX	TiCN coated carbide grade. Excellent grade for general use .	
	VTX	TiAlN coated carbide grade. Excellent grade for general use and hardened materials .	
Solid Carbide	VTH	TiCN coated carbide grade. Excellent grade for general use .	

Other grades are available upon request.



GEAR MILLING Request Form*

* Please submit a completed version of this form with each request (a drawing is recommended).
For Rack, Straight Spline, Worm or other special forms, a drawing **must** be supplied with all relevant dimensions!

Basic Dimensions

- 1 | Gear / Spline Standard _____
- 2 | Class of Accuracy _____
- 3 | Module (M) / Diametral Pitch (DP) _____
- 4 | Number of Teeth _____
- 5 | Pressure Angle _____
- 6 | Helix Angle _____
- 7 | Direction of Helix (RH/LH) _____
- 8 | Pitch Diameter (REF) _____
- 9 | Major Diameter Max: _____ Min: _____
- 10 | Minor Diameter Max: _____ Min: _____
- 11 | Form Diameter (For Spline only) _____
- 12 | Fillet Radius _____
- 13 | Root Type (For Spline only) Fillet Root Flat Root

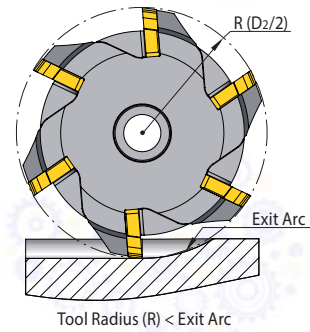
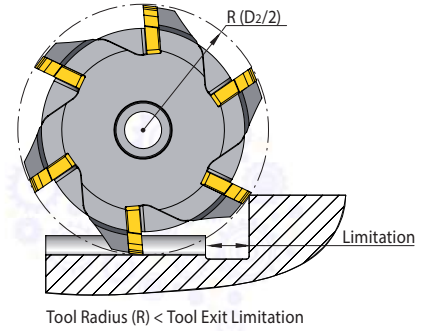

One of the following must be supplied:

- 14a | Measurement Over Pins \varnothing : _____ Max: _____ Min: _____
- 14b | Tangent Length Over (N) Teeth N: _____ Max: _____ Min: _____
- 14c | Actual - Tooth Thickness Max: _____ Min: _____

Additional Information

- 15 | For Tool Exit Limitation, a detailed component drawing must be supplied!
- 16 | Exit Arc Radius (R) _____
- 17 | Material Hardness (During machining) _____
- 18 | Material Designation _____

Flat Root Spline

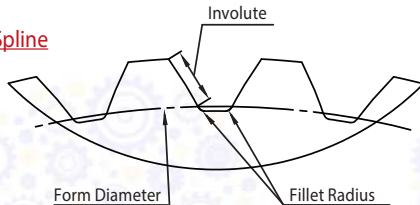

Fillet Root Spline

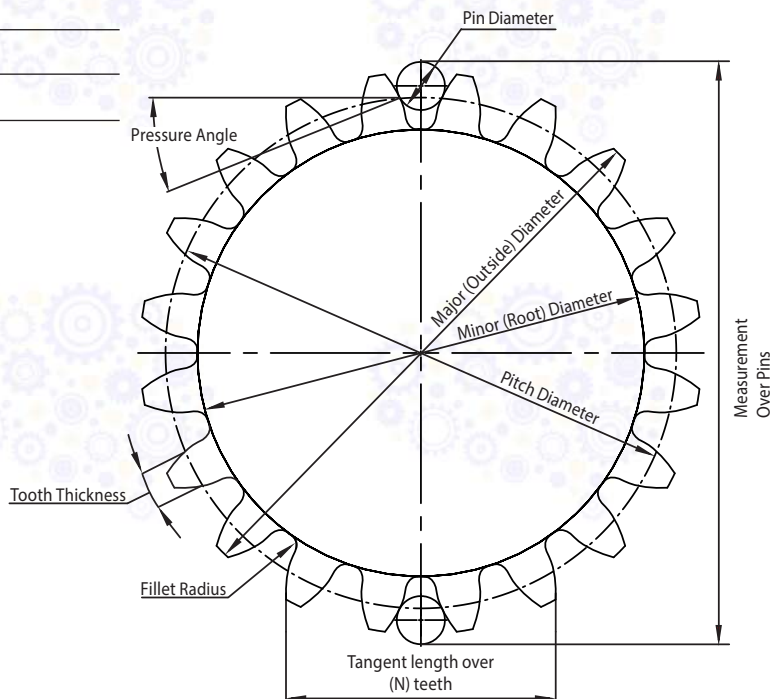
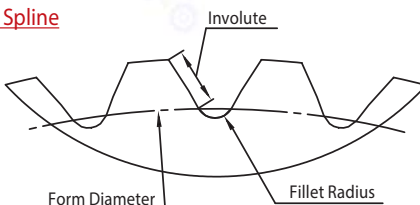



GEAR MILLING
For Gear, Spline & Rack Manufacturing



VARDEX
Advanced Threading Solutions

