

GROOVEX

Innovative Grooving & Turning Solutions

MAIN CATALOG | METRIC

EXTERNAL GROOVE TURNING

INTERNAL GROOVE TURNING

GROOVE MILLING



VARGUS is a world leading developer, manufacturer and supplier of high-quality, precision threading, grooving, turning and hand deburring tools.

Established in 1960, VARGUS is the cutting tools division of the NEUMO Ehrenberg Group, a multinational organization headquartered in Germany.

With 13 international subsidiaries, and a network of distributors, warehouses and certified ISO 9001 manufacturing facilities, VARGUS Ltd. serves customers in more than 100 countries around the globe. A customer-focused organization, VARGUS Ltd. is committed to providing products and solutions of the highest quality and excellent value, and is renowned for its technical expertise and uncompromising service.

COMPANY PRODUCTS:

GROOVEX

Innovative Grooving & Turning Solutions

, the newest product line by VARGUS, provides innovative solutions for grooving, boring and turning, in a wide range of applications.

EXTERNAL GROOVE TURNING:

VG-Cut – Complete Range of Turning Solutions for Grooving, Parting Off, Turning & Profiling, Face Grooving, and Threading.

ST-Cut – Precise tools for external machining on Swiss type machines for a broad range of applications.

GrooVical – Precise Grooving & Turning for shallow grooves, with accurate grounded notch.

Laydown Grooving – Standard laydown grooving inserts for general use in internal and external grooving applications.

INTERNAL GROOVE TURNING:

microscope – Micromachining Solutions for Boring, Grooving & Threading in Bores smaller than 1.0mm.

Mini-V – All-Inclusive Range of Small Parts Machining Solutions for Boring, Grooving & Threading in Bores from 7.8mm.

GROOVE MILLING:

GM Solid – Solid carbide groove milling tools for miniature and small bores.

GM Slot – Indexable groove milling tools for Grooving and Chamfering applications.

VARDEX

Advanced Threading Solutions

is the company's prominent product line for Thread Turning, Thread Milling, Gear Milling Solutions, and specialized solutions for the Oil & Gas and Medical Industries.

SHAVIV

Leading Deburring Solutions

, manufactures world leading hand-deburring solutions for metal, plastic and wood.



ТОВ «СМАРТТЕК ІНЖИНІРИНГ», Т. +380-50-396-90-96, info@smarttec.com.ua, https://www.smarttec.com.ua



СМАРТТЕК
РОЗУМНІ ТЕХНОЛОГІЇ



This updated and extended version of the MAIN GROOVEX CATALOG now includes the newest GROOVEX products and expansions, followed by the **GROOVEX MAIN CATALOG, Edition 07**.

Index

2022 PRODUCTS AND EXPANSIONS



2022 NEW PRODUCTS AND EXPANSIONS N5 - N14

MAIN CATALOG

Table of Contents	2 - 4
External Groove Turning	5 - 90
Internal Groove Turning	91 - 182
Groove Milling	183 - 200



ТОВ «СМАРТТЕК ІНЖИНІРИНГ», Т. +380-50-396-90-96, info@smarttec.com.ua, https://www.smarttec.com.ua



GROOVEX

Innovative Grooving & Turning Solutions

2022 NEW PRODUCTS AND EXPANSIONS



СМАРТТЕК
РОЗУМНІ ТЕХНОЛОГІЇ

2022 NEW PRODUCTS AND EXPANSIONS



microbroach **NEW**

Dedicated broaching tools for Hexagon and Torx® sockets N-5



ST-Cut **NEW**

Back Turning and Front Turning Applications N-8



microscope **NEW**

New Microscope Chip Breaker for Internal Grooving Applications N-11



NEW

microbroach

Dedicated broaching tools
for Hexagon and Torx®
sockets

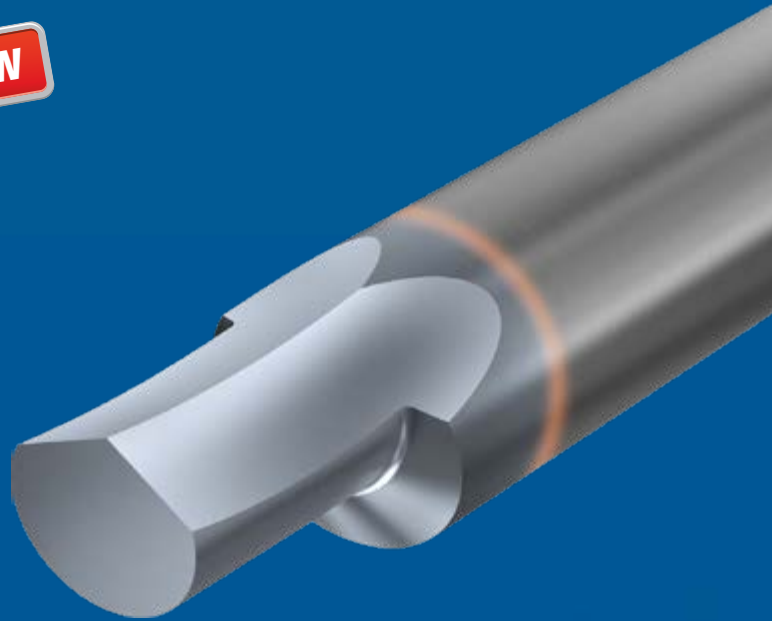

Features and Benefits:

- Unique VARGUS design
- Fits popular driven tools
- Sockets range:



Hexagon sockets

2.5 mm – 10.0 mm



Torx® sockets

TX15 – TX30



ТОВ «СМАРТТЕК ІНЖИНІРИНГ», т. +380-50-396-90-96, info@smarttec.com.ua, <https://www.smarttec.com.ua>



Inserts

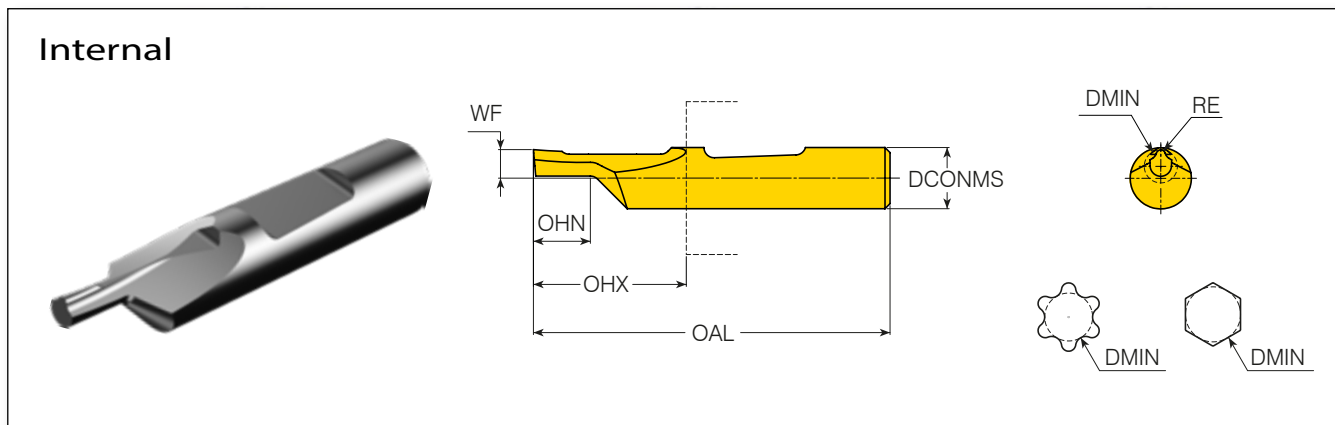

Application	App Range	DCONMS	DMIN	Ordering Code	Dimensions mm						Grades
					TX/SW	WF	RE	OHN	OHX	OAL	
Torx Socket	TX15	6.0	2.40	B6.0TX15R0.34	15	2.90	0.34	4.00	15.00	35.00	•
	TX20		2.85	B6.0TX20R0.40	20	2.90	0.40	4.00	15.00	35.00	•
	TX25		3.25	B6.0TX25R0.45	25	2.90	0.45	5.00	15.00	35.00	•
	TX30		4.05	B6.0TX30R0.56	30	2.90	0.56	5.00	15.00	35.00	•
Hexagon Socket	2.0	6.0	2.00	B6.0HW2R0.05	2.0	2.90	0.05	4.00	15.00	35.00	•
	2.5-2.9		2.50	B6.0HW2.5R0.05	2.5	2.90	0.05	4.00	15.00	35.00	•
	2.9-3.5		3.00	B6.0HW3R0.05	3.0	2.90	0.05	4.50	15.00	35.00	•
	3.5-4.0		3.50	B6.0HW3.5R0.05	3.5	2.90	0.05	5.50	15.00	35.00	•
	4.0-4.5		4.00	B6.0HW4R0.1	4.0	2.90	0.1	6.00	15.00	35.00	•
	4.5-5.0		4.50	B6.0HW4.5R0.1	4.5	2.90	0.1	7.00	15.00	35.00	•
	5.0-8.0	5.00	B6.0HW5R0.1	5.0	2.90	0.1	9.00	15.00	35.00	•	
8.0-10.0	10.0	8.00	B10.0HW8R0.1	8.0	4.90	0.1	12.00	20.00	45.00	•	

• In stock

Shank Type BE*

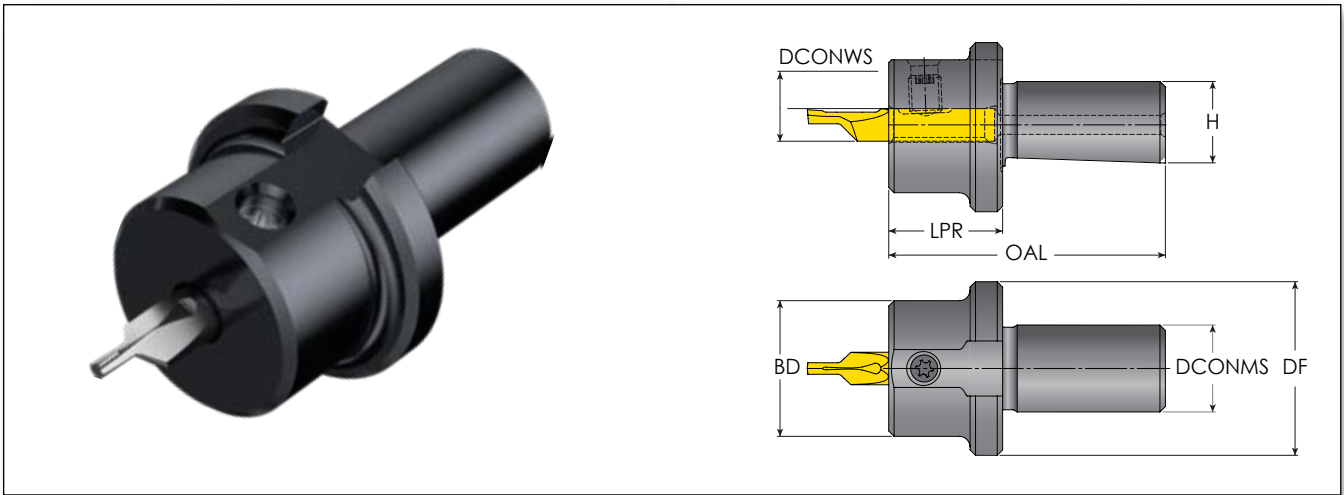

Shank Type	DCONWS	Ordering Code	Dimensions mm						Spare Parts	
			DCONMS	BD	DF	H	LPR	OAL	Clamping Screw	Key
BE	06	BH16-06-BE	16	25	32	15	21	51.00	SL7DT15	LT15
	10	BH16-10-BE	16	25	32	15	31	61.00		

* BE holders are specially designed for EWS-Slot and BENZ LinA broaching devices

Shank Type C4F

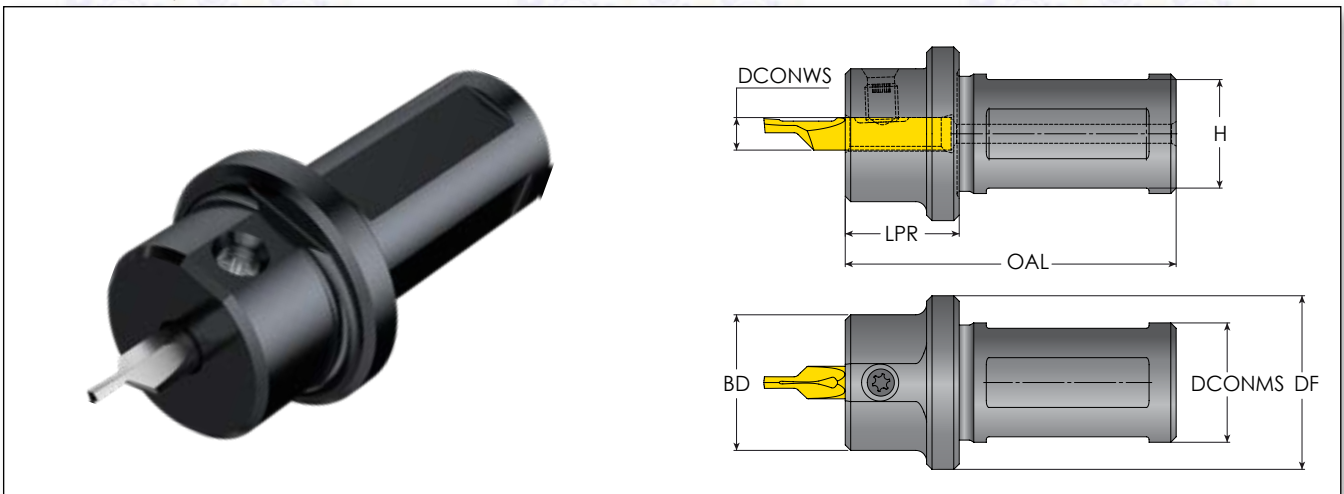

Shank Type	DCONWS	Ordering Code	Dimensions mm						Spare Parts	
			DCONMS	BD	DF	H	LPR	OAL	Clamping Screw	Key
C4F	06	BH20-06-C4F	20	25	32	18	21	61.00	SL7DT15	LT15
	10	BH20-10-C4F	20	25	32	18	26	66.00		
	06	BH22-06-C4F	22	25	32	20	21	61.00		
	10	BH22-10-C4F	22	25	32	20	26	66.00		
	06	BH25-06-C4F	25	25	32	23	21	61.00		
	10	BH25-10-C4F	25	25	32	23	26	66.00		

ST-Cut

ST-CUT Precise Tools for Small Parts Machining

Back Turning and Front Turning Applications

NEW

Vargus is pleased to introduce the expansion of the **ST-Cut** Line - front and back turning applications - for external machining of small parts on Swiss type machines.

Features and Benefits:

- Outstanding chip control
- Unique insert replacement system
- Quick and easy change of insert inside the machine from both sides of the tool
- High repeatability of the cutting edge on all axes
- Excellent rigidity for stable machining
- Insert edge treatment for increased tool life

Front Turning

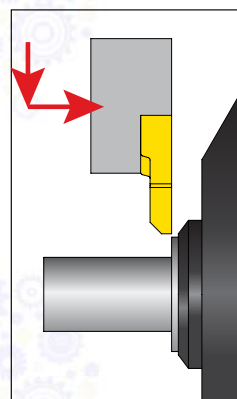

Back Turning

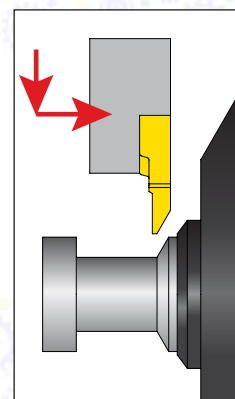

See the complete range of **ST-Cut** tools in pages: 45 - 62

Front Turning

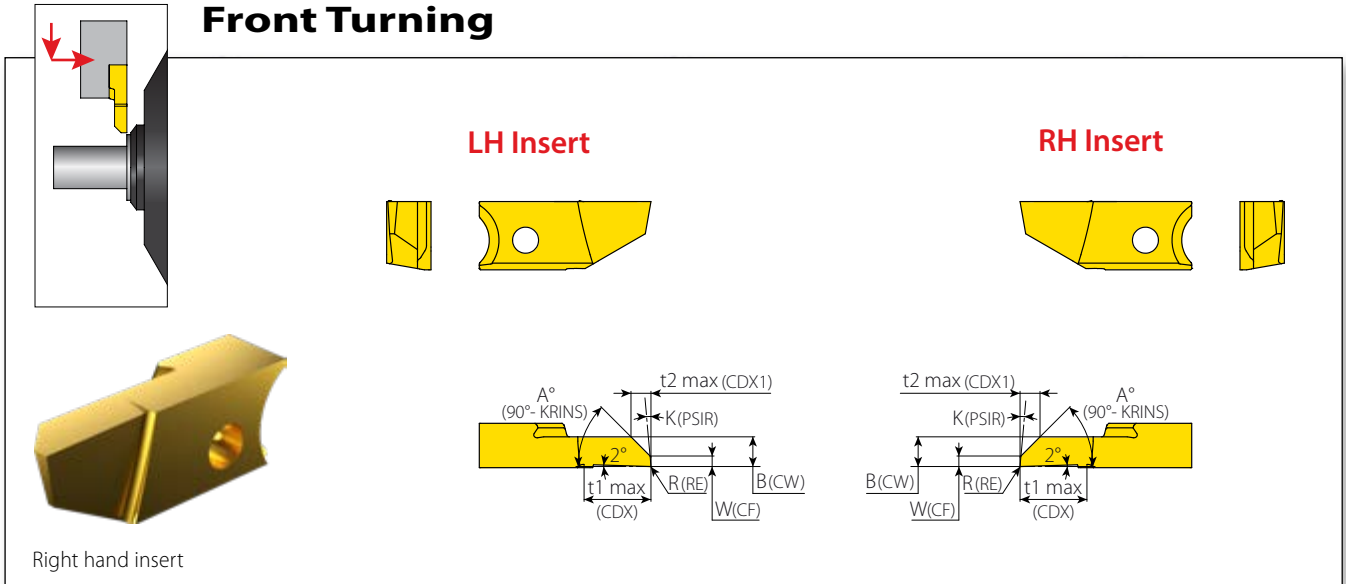

Ordering Code	Dimensions mm non ISO (ISO)							Grade
	B (CW)	W (CF)	A° (90°- KRINS)	R (RE)	t1 max (CDX)	t2 max (CDX1)	K° (PSIR)	VPG
ST85RFTC0-18-00-W0.5E	3	0.5	18	-	6.5	7.5	-	•
ST85LFTC0-18-00-W0.5E	3	0.5	18	-	6.5	7.5	-	•
ST85RFT0-45-00-W1.0E	3	1.0	45	-	6.5	2.0	-	•
ST85LFT0-45-00-W1.0E	3	1.0	45	-	6.5	2.0	-	•
ST85RFT0-45-0.20-W1.0E	3	1.0	45	0.2	6.5	2.0	-	•
ST85LFT0-45-0.20-W1.0E	3	1.0	45	0.2	6.5	2.0	-	•
ST85RFT6-45-00-W1.0E	3	1.0	45	-	6.5	2.0	-	•
ST85LFT6-45-00-W1.0E	3	1.0	45	-	6.5	2.0	-	•
ST85RFT6-45-0.20-W1.0E	3	1.0	45	0.2	6.5	2.0	-	•
ST85LFT6-45-0.20-W1.0E	3	1.0	45	0.2	6.5	2.0	-	•

• In stock ◦ Available upon request

See the complete range of **ST-Cut** tools in pages: 45 - 62



Back Turning

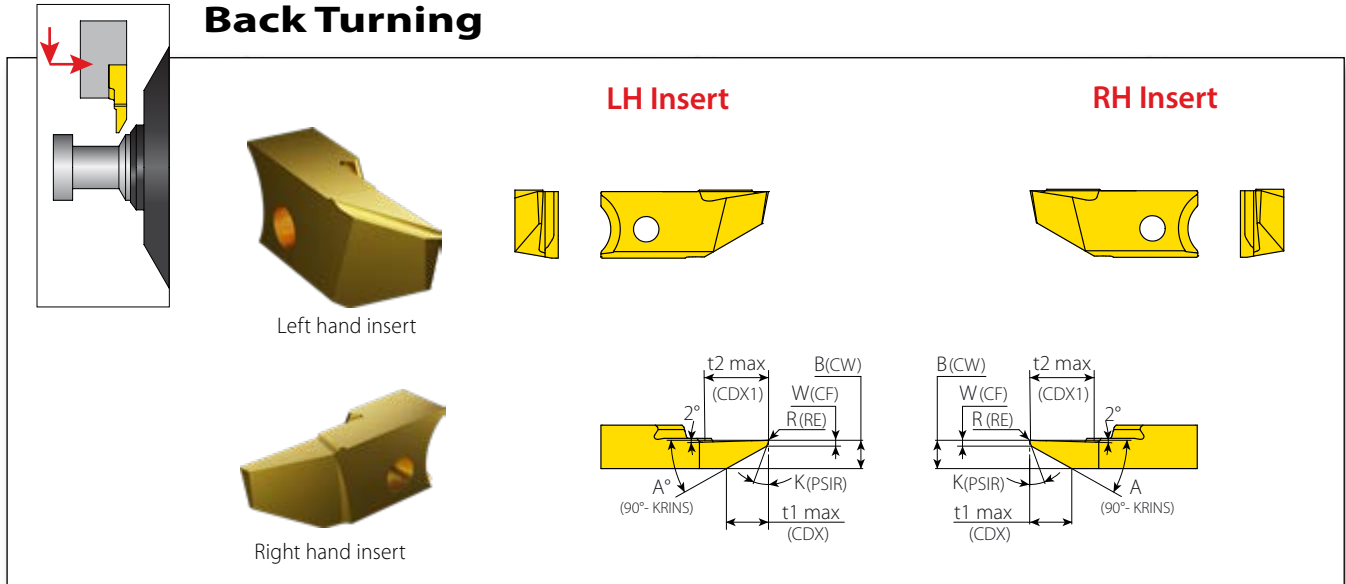

Ordering Code	Dimensions mm non ISO (ISO)							Grade
	B (CW)	W (CF)	A° (90°- KRINS)	R (RE)	t1 max (CDX)	t2 max (CDX1)	K° (PSIR)	VPG
ST85RBT0-18-00-W0.5E	3	0.5	18	-	7.7	6.5	-	•
ST85LBT0-18-00-W0.5E	3	0.5	18	-	7.7	6.5	-	•
ST85RBT0-18-00-W1.0E	3	1.0	18	-	6.1	6.5	-	•
ST85LBT0-18-00-W1.0E	3	1.0	18	-	6.1	6.5	-	•
ST85RBT6-18-00-W0.5E	2	0.5	18	-	4.6	5.3	-	•
ST85LBT6-18-00-W0.5E	2	0.5	18	-	4.6	5.3	-	•
ST85RBT6-18-00-W1.0E	2.5	1.0	18	-	4.6	5.3	-	•
ST85LBT6-18-00-W1.0E	2.5	1.0	18	-	4.6	5.3	-	•
ST85RBTC6-25-0.05-20W0.5E	3	0.5	25	0.05	5.3	6.5	20	•
ST85LBTC6-25-0.05-20W0.5E	3	0.5	25	0.05	5.3	6.5	20	•
ST85RBTC6-25-0.20-20W1.0E	3	1.0	25	0.2	4.3	6.5	20	•
ST85LBTC6-25-0.20-20W1.0E	3	1.0	25	0.2	4.3	6.5	20	•
ST85RBTC6-30-00-W1.0E	3	1.0	30	-	3.4	6.5	-	•
ST85LBTC6-30-00-W1.0E	3	1.0	30	-	3.4	6.5	-	•
ST85RBTC6-30-0.05-W1.0E	3	1.0	30	0.05	3.4	6.5	-	•
ST85LBTC6-30-0.05-W1.0E	3	1.0	30	0.05	3.4	6.5	-	•
ST85RBTC6-30-0.20-W1.0E	3	1.0	30	0.2	3.4	6.5	-	•
ST85LBTC6-30-0.20-W1.0E	3	1.0	30	0.2	3.4	6.5	-	•
ST85RBTC9-30-0.10-20W0.5E	3	0.5	30	0.1	4.5	6.5	20	•
ST85LBTC9-30-0.10-20W0.5E	3	0.5	30	0.1	4.5	6.5	20	•

• In stock ◦ Available upon request



See the complete range of **ST-Cut** tools in pages: 45 - 62

NEW

microscope

New Microscope Chip Breaker for Internal Grooving Applications

New chip breaker design offers a unique solution in a wide range of groove widths

Features and Benefits:

- Advanced chip control, producing shorter chips
- Reduced cutting forces
- VTX grade for wide range of materials
- Wide range of grooving widths
1.00 mm - 2.00 mm
- Superior surface finish
- Exceptional chip evacuation
- Improved tool life
- Excellent for blind holes
- Minimum bore diameter - 5.2 mm

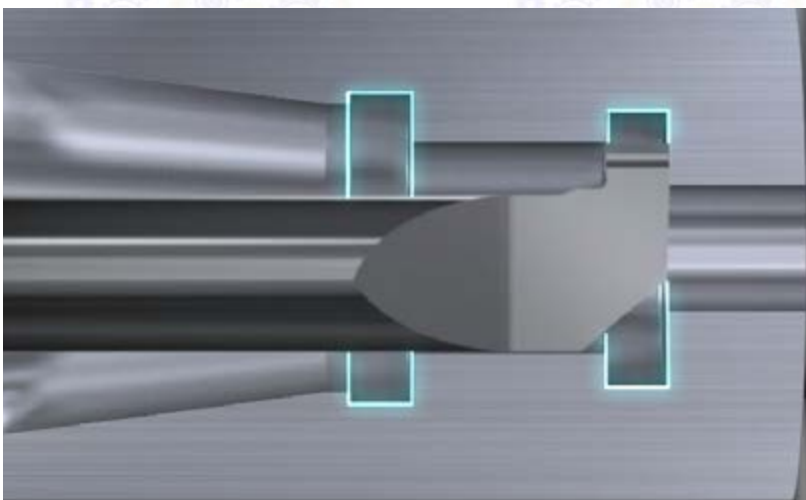

See the complete range of **microscope** tools in pages: 141 - 181

New Microscope Chip Breaker for Internal Grooving Applications

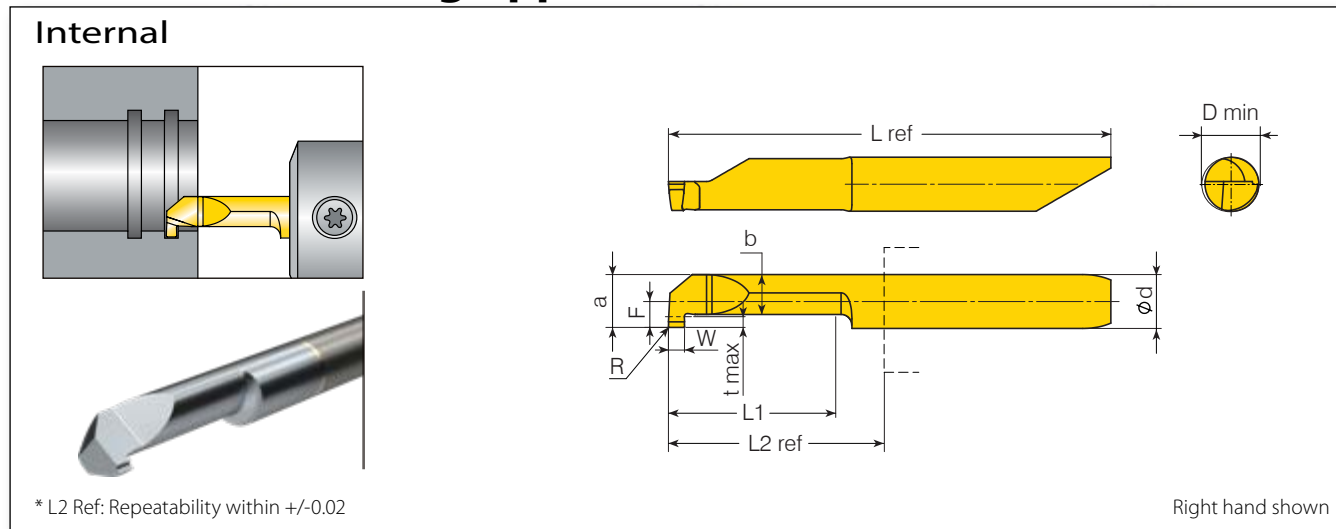

Shank Dia.	Min. Bore Dia.	Ordering Code	Dimensions mm									
d (mm)	D min. (mm)	RH/LH	W ^{±0.025}	t max	L1	F	R	a	b	L2 ref*	L ref	VTX
5.0	5.2	M552GCBS100L10RCE VTX	1.00	0.98	10.00	2.40	0.10	4.90	3.70	12.15	35.00	•
		M552GCBS150L15RCE VTX	1.50	0.98	16.00	2.40	0.10	4.90	3.70	18.15	41.00	•
		M552GCBS100L10RE VTX	1.00	0.98	10.00	2.40	0.10	4.90	3.70	12.15	35.00	•
		M552GCBS100L15LE VTX	1.00	0.98	16.00	2.40	0.10	4.90	3.70	18.15	41.00	•
		M552GCBS100L15RE VTX	1.00	0.98	16.00	2.40	0.10	4.90	3.70	18.15	41.00	•
		M552GCBS100L20RE VTX	1.00	0.98	21.00	2.40	0.10	4.90	3.70	22.80	46.00	•
		M552GCBS150L10RE VTX	1.50	0.98	10.00	2.40	0.10	4.90	3.70	12.15	35.00	•
		M552GCBS150L15LE VTX	1.50	0.98	16.00	2.40	0.10	4.90	3.70	18.15	41.00	•
		M552GCBS150L15RE VTX	1.50	0.98	16.00	2.40	0.10	4.90	3.70	18.15	41.00	•
		M552GCBS150L20LE VTX	1.50	0.98	21.00	2.40	0.10	4.90	3.70	23.15	46.00	•
		M552GCBS150L20RE VTX	1.50	0.98	21.00	2.40	0.10	4.90	3.70	23.15	46.00	•
		M552GCBS200L10RE VTX	2.00	0.98	10.00	2.40	0.10	4.90	3.70	12.15	35.00	•
M552GCBS200L15RE VTX	2.00	0.98	16.00	2.40	0.10	4.90	3.70	18.15	41.00	•		
M552GCBS200L20RE VTX	2.00	0.98	21.00	2.40	0.10	4.90	3.70	23.15	46.00	•		
6.00	6.20	M662GCBS079L10RE VTX	0.79	1.70	10.00	2.90	0.10	5.90	3.95	12.30	36.00	•
		M662GCBS079L15RE VTX	0.79	1.70	15.00	2.90	0.10	5.90	3.95	18.30	42.00	•
		M662GCBS079L35RE VTX	0.79	1.70	35.00	2.90	0.10	5.90	3.95	37.30	61.00	•
		M662GCBS100L10RE VTX	1.00	1.70	10.00	2.90	0.10	5.90	3.95	12.30	36.00	•
		M662GCBS100L15RE VTX	1.00	1.70	15.00	2.90	0.10	5.90	3.95	18.30	42.00	•
		M662GCBS100L20RE VTX	1.00	1.70	20.00	2.90	0.10	5.90	3.95	23.30	47.00	•
		M662GCBS100L30RE VTX	1.00	1.70	30.00	2.90	0.10	5.90	3.95	32.30	56.00	•
		M662GCBS150L10RE VTX	1.50	1.70	10.00	2.90	0.10	5.90	3.95	12.30	36.00	•
		M662GCBS150L15RE VTX	1.50	1.70	15.00	2.90	0.10	5.90	3.95	18.30	42.00	•
		M662GCBS150L20LE VTX	1.50	1.70	20.00	2.90	0.10	5.90	3.95	23.30	47.00	•
		M662GCBS150L20RE VTX	1.50	1.70	20.00	2.90	0.10	5.90	3.95	23.30	47.00	•
		M662GCBS150L30RE VTX	1.50	1.70	30.00	2.90	0.10	5.90	3.95	32.30	56.00	•
		M662GCBS157L35RE VTX	1.57	1.70	35.00	2.90	0.10	5.90	3.95	37.30	61.00	•
		M662GCBS200L10RE VTX	2.00	1.70	10.00	2.90	0.10	5.90	3.95	12.30	36.00	•
		M662GCBS200L15LE VTX	2.00	1.70	15.00	2.90	0.10	5.90	3.95	18.30	42.00	•
		M662GCBS200L15RE VTX	2.00	1.70	15.00	2.90	0.10	5.90	3.95	18.30	42.00	•
		M662GCBS200L20RE VTX	2.00	1.70	21.00	2.90	0.10	5.90	3.95	23.30	47.00	•
		M662GCBS200L30RE VTX	2.00	1.70	30.00	2.90	0.10	5.90	3.95	32.30	56.00	•

See the complete range of microscope tools in pages: 141 - 181

New Microscope Chip Breaker for Internal Grooving Applications

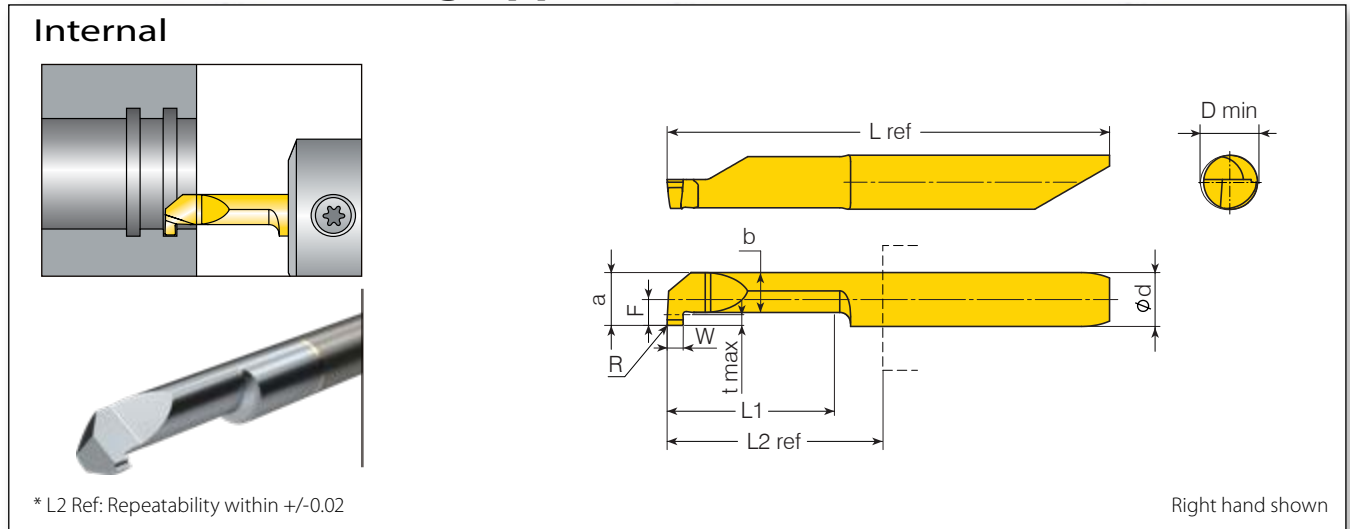

Shank Dia.	Min. Bore Dia.	Ordering Code	Dimensions mm									
d (mm)	D min. (mm)	RH/LH	W ^{±0.025}	t max	L1	F	R	a	b	L2 ref*	L ref	VTX
7.00	7.20	M772GCBS100L10RE VTX	1.00	2.50	10.00	3.40	0.10	6.90	4.10	11.40	36.00	•
		M772GCBS100L15RE VTX	1.00	2.50	15.00	3.40	0.10	6.90	4.10	16.40	41.00	•
		M772GCBS100L25RE VTX	1.00	2.50	25.00	3.40	0.10	6.90	4.10	26.40	51.00	•
		M772GCBS100L35RE VTX	1.00	2.50	35.00	3.40	0.10	6.90	4.10	36.40	61.00	•
		M772GCBS150L10RE VTX	1.50	2.50	10.00	3.40	0.10	6.90	4.10	11.40	36.00	•
		M772GCBS150L15RE VTX	1.50	2.50	15.00	3.40	0.10	6.90	4.10	16.40	41.00	•
		M772GCBS150L25RE VTX	1.50	2.50	25.00	3.40	0.10	6.90	4.10	26.40	51.00	•
		M772GCBS150L35RE VTX	1.50	2.50	35.00	3.40	0.10	6.90	4.10	36.40	61.00	•
		M772GCBS200L10RE VTX	2.00	2.50	10.00	3.40	0.10	6.90	4.10	11.40	36.00	•
		M772GCBS200L15RE VTX	2.00	2.50	15.00	3.40	0.10	6.90	4.10	16.40	41.00	•
		M772GCBS200L25LE VTX	2.00	2.50	25.00	3.40	0.10	6.90	4.10	26.40	51.00	•
		M772GCBS200L25RE VTX	2.00	2.50	25.00	3.40	0.10	6.90	4.10	26.40	51.00	•
M772GCBS200L35RE VTX	2.00	2.50	35.00	3.40	0.10	6.90	4.10	36.40	61.00	•		



See the complete range of microscope tools in pages: 141 - 181

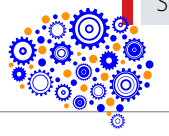

SMARTTEK
РОЗУМНІ ТЕХНОЛОГІЇ

ТОВ «СМАРТТЕК ІНЖИНІРИНГ», Т. +380-50-396-90-96, info@smarttec.com.ua, https://www.smarttec.com.ua



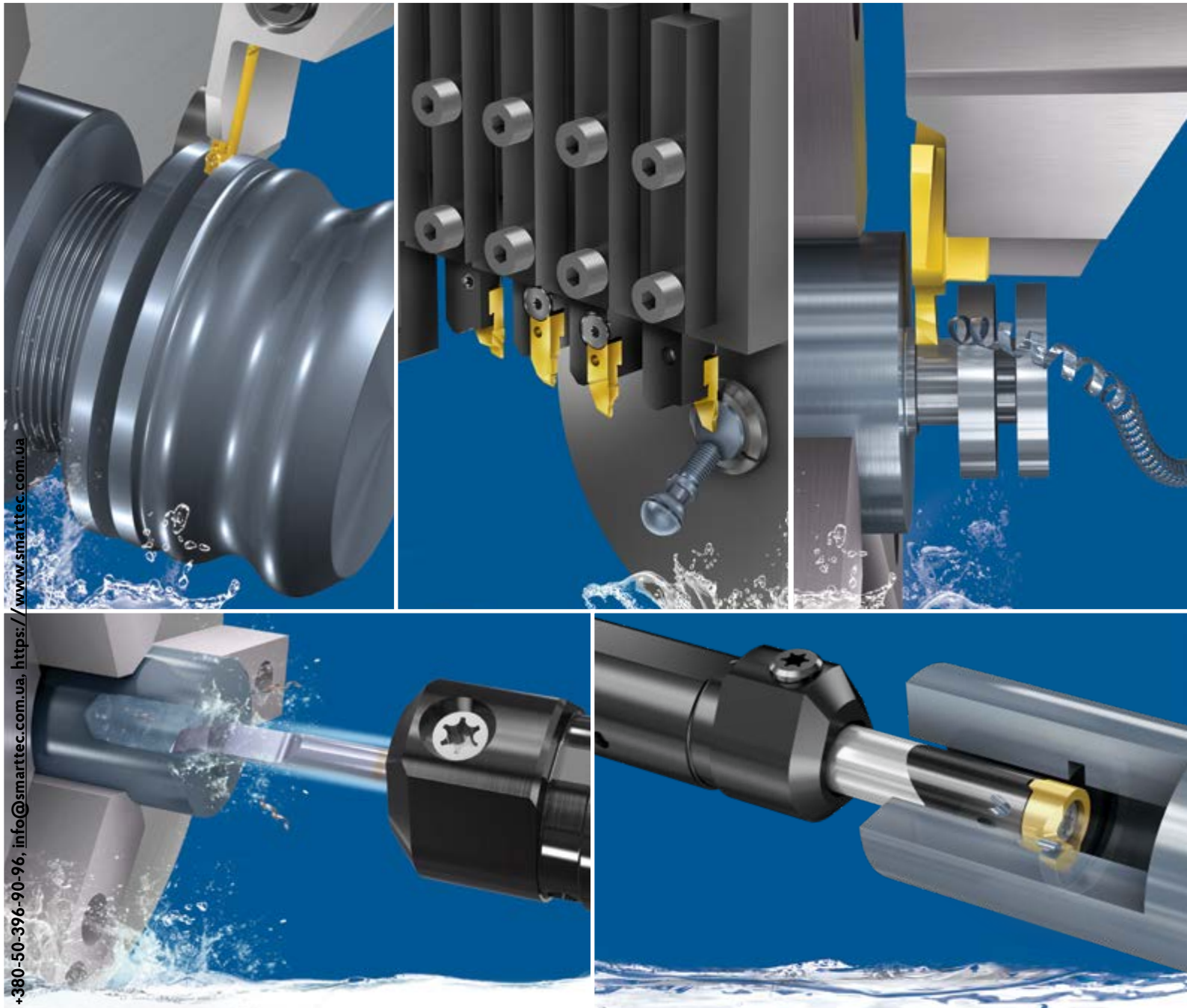

GROOVEX

Innovative Grooving & Turning Solutions

MAIN CATALOG | METRIC

EXTERNAL GROOVE TURNING

INTERNAL GROOVE TURNING

GROOVE MILLING

ТОВ «СМАРТТЕК ІНЖИНІРИНГ», Т. +380-50-396-90-96, info@smarttec.com.ua, https://www.smarttec.com.ua





EXTERNAL GROOVE TURNING

Semi Finishing



Complete Range of Turning Solutions

Introduction	8
Technical Data	12

Inserts

Ordering Code System	23
Parting Off & Deep Grooving:	
Double Sided Inserts (1.5 - 6.0 mm)	24
Single Sided Inserts (2.0 - 4.0 mm)	26
Turning & Profiling (2.0 - 6.0 mm)	27
Threading (3.0 mm)	28

Toolholders

Ordering Code System	30
External Monoblock Tools with HPC	31
External Monoblock Tools	32
Reinforced Monoblock Tools with HPC	33
Reinforced Monoblock Tools	34
Blades with HPC	35
Blades	35
Reinforced Blades (Screw Clamping) with HPC	36
Reinforced Blades (Screw Clamping)	37
Reinforced Blades	38
Blade Holders	38
Radial Modules	39
Modular Bodies	40
Radial Modules with HPC	41
Face Grooving Modules with HPC	42
Modular Bodies with HPC	43
Modular V-CAP Holders with HPC	44

Finishing



Precise Tools for Small Parts Machining

Introduction	46
Technical Data	47

Inserts

Ordering Code System	51
Parting Off	52
Groove & Turn	54
Square Grooving	55
Round Grooving	56
Threading	57

Toolholders

Ordering Code System	59
Square Shank Tools	60
Stepped Square Shank Tools	61
Square Shank 90° Tools	62



Precise Grooving & Turning Applications

Introduction	64
Technical Data	65

Inserts

Ordering Code System	67
----------------------------	----

GVN26 & GVN29 Close to Shoulder:

Super Positive Rake Grooving	68
Turning & Grooving Chip Former	69
Square Grooving	70
Round Grooving	71
Parting Off	72

GV29 Neutral:

Square Grooving	73
Round Grooving	73

Toolholders

Ordering Code System.....	74
Close to Shoulder External Toolholders.....	75
Close to Shoulder External Toolholders 90°.....	76
Modules with HPC.....	77
Modular Bodies with HPC.....	78
Modular V-CAP Holders with HPC.....	79
External Toolholders (GV29).....	80
External Toolholders 90° (GV29).....	80



Laydown Grooving

For Shallow Grooves

Technical Data.....	82
---------------------	----

Inserts

Ordering Code System.....	83
DIN 471 Retaining Ring Grooves for Shafts.....	84
DIN 7993 Snap Ring Grooves.....	85
CIRCLIP Inch Standard.....	85
DIN 76 Thread Undercuts.....	86

Toolholders

Ordering Code System.....	87
External Standard Toolholders.....	88
External Standard Toolholders with Clamp.....	89

INTERNAL GROOVE TURNING

Semi Finishing



VG-Cut

Complete Range of Turning Solutions

Technical Data.....	94
---------------------	----

Toolholders

Ordering Code System.....	97
Internal VG-Cut.....	98

Finishing



GrooVical

Precise Grooving & Turning Applications

Technical Data.....	100
---------------------	-----

Toolholders

Ordering Code System.....	102
---------------------------	-----

Close to Shoulder Internal Toolholders.....	103
---	-----

Internal Toolholders (GV29).....	103
----------------------------------	-----



Laydown Grooving

For Shallow Grooves

Technical Data.....	106
---------------------	-----

Inserts

Ordering Code System.....	107
DIN 472 Retaining Ring Grooves for Bores.....	108
DIN 7993 Snap Ring Grooves.....	109
CIRCLIP Inch Standard.....	110
DIN 76 Thread Undercuts.....	111

Toolholders

Ordering Code System.....	112
Internal Standard Toolholders.....	113
Internal Standard Toolholders with Clamp.....	114
Internal Standard Carbide Shank Toolholder.....	115



Mini-V

Precise Turning, Grooving, Threading & Face Grooving

Introduction.....	118
Technical Data.....	120

Inserts

Ordering Code System.....	122
Boring.....	123
Boring with Chip Former.....	123
Boring & Profiling 30°.....	124
Boring & Profiling 45°.....	124
Back Boring.....	125
Boring & Chamfering.....	125
Grooving DIN 472 - Sharp Corner Radius.....	126
Square Grooving - 0.05 mm Corner Radius.....	127
Square Grooving.....	128
Round Grooving - DIN 7993.....	129
Square Face Grooving.....	130
Round Face Grooving.....	131
Threading.....	132

Toolholders

Ordering Code System.....	135
Alloy Steel Shank.....	136

Reinforced Alloy Steel Shank.....	136
Carbide Shank.....	137
Reinforced Carbide Shank.....	138
Carbide Shank for Sleeves.....	138
V-CAP Holders.....	139
Micro Holders for Carbide Shank Sleeve Clamping.....	139



microscope

Mini Tools for Small & Medium Bores

Introduction.....	142
Technical Data.....	144

Inserts

Ordering Code System.....	149
Boring with HPC.....	150
Boring.....	151
Boring with Chip Breaker and HPC.....	154
Boring with Chip Breaker.....	155
Boring with Chip Former and HPC.....	156
Boring with Chip Former.....	157
Boring 20°.....	158
Boring 90°.....	158
Boring & Profiling with Chip Breaker & HPC (CBLF).....	159
Boring & Profiling (CL) with HPC.....	160
Boring & Profiling (CL).....	160
Back Boring.....	161
Boring & Chamfering 45°.....	161
Square Grooving with HPC.....	162
Square Grooving.....	163
Round Grooving.....	165
Pre-Part Off.....	165
Face Grooving with HPC.....	166
Face Grooving.....	167
Round Face Grooving with HPC.....	168
Face Chamfering 45°.....	168
Threading.....	169

Toolholders

Ordering Code System.....	172
V-Cap Holders.....	173
Shrink Toolholders.....	174
Round Toolholders without Shoulder.....	175
Round Double-Sided Tools.....	175

Holder with Round Shank - 4 Flats.....	176
Holder with Round Shank - 2 Flats.....	177
Square Shank Toolholders.....	178
Drop Head Toolholders.....	179

Groove Turning Accessories

Torque Limiters.....	180
Torque Limiters Appendix.....	181

GROOVE MILLING



GM Solid

Solid Carbide Groove Milling Tools

Introduction.....	186
Technical Data.....	187
GM Solid Tools	
Ordering Code System.....	188
Square Grooving.....	189
Chamfering.....	190



GM Slot

Square Grooving, Round Grooving and Chamfering

Introduction.....	192
Technical Data.....	193

Inserts

Ordering Code System.....	194
Square Grooving.....	195
Round Grooving.....	196
Chamfering.....	197

Toolholders

Ordering Code System.....	198
Carbide Cylindrical Shanks.....	199
Weldon Shanks.....	200



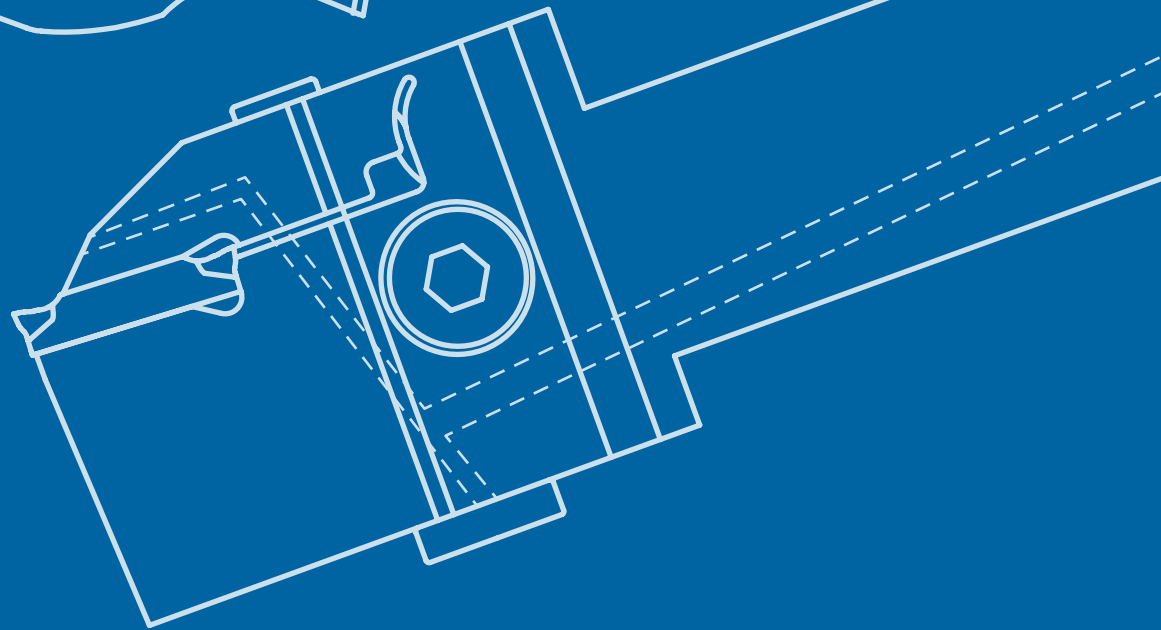
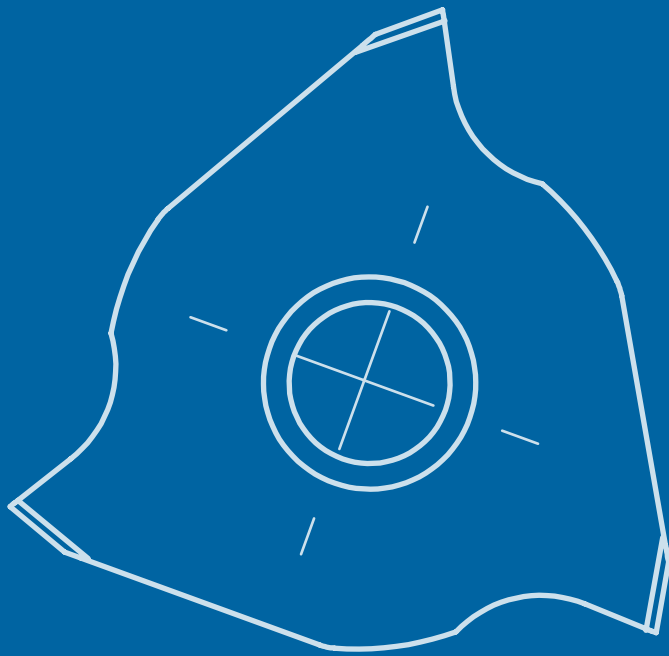

EXTERNAL GROOVE TURNING

Semi Finishing VG-Cut	7
Finishing ST-Cut	45
GrooVical	63
Laydown Grooving	81







EXTERNAL GROOVE TURNING | SEMI FINISHING

VG-Cut

Deep Grooving, Threading, Turning,
Parting Off & Face Grooving Applications



VG-Cut | Complete Range of Turning Solutions

Deep Grooving, Threading, Parting Off, Boring and Face Grooving

VG-Cut tools provide a wider range of applications and options within the same insert pocket of Deep Grooving, Parting Off, Turning, Profiling, Boring, Face Grooving and Threading. VG-Cut inserts also offer a variety of chip formers and carbide grades, making the **VG-Cut** program a distinctly versatile system. **VG-Cut** inserts are designed with a unique multifunctional and diverse geometry, **starting at 1.5mm**, to minimize inventory for the end-user.

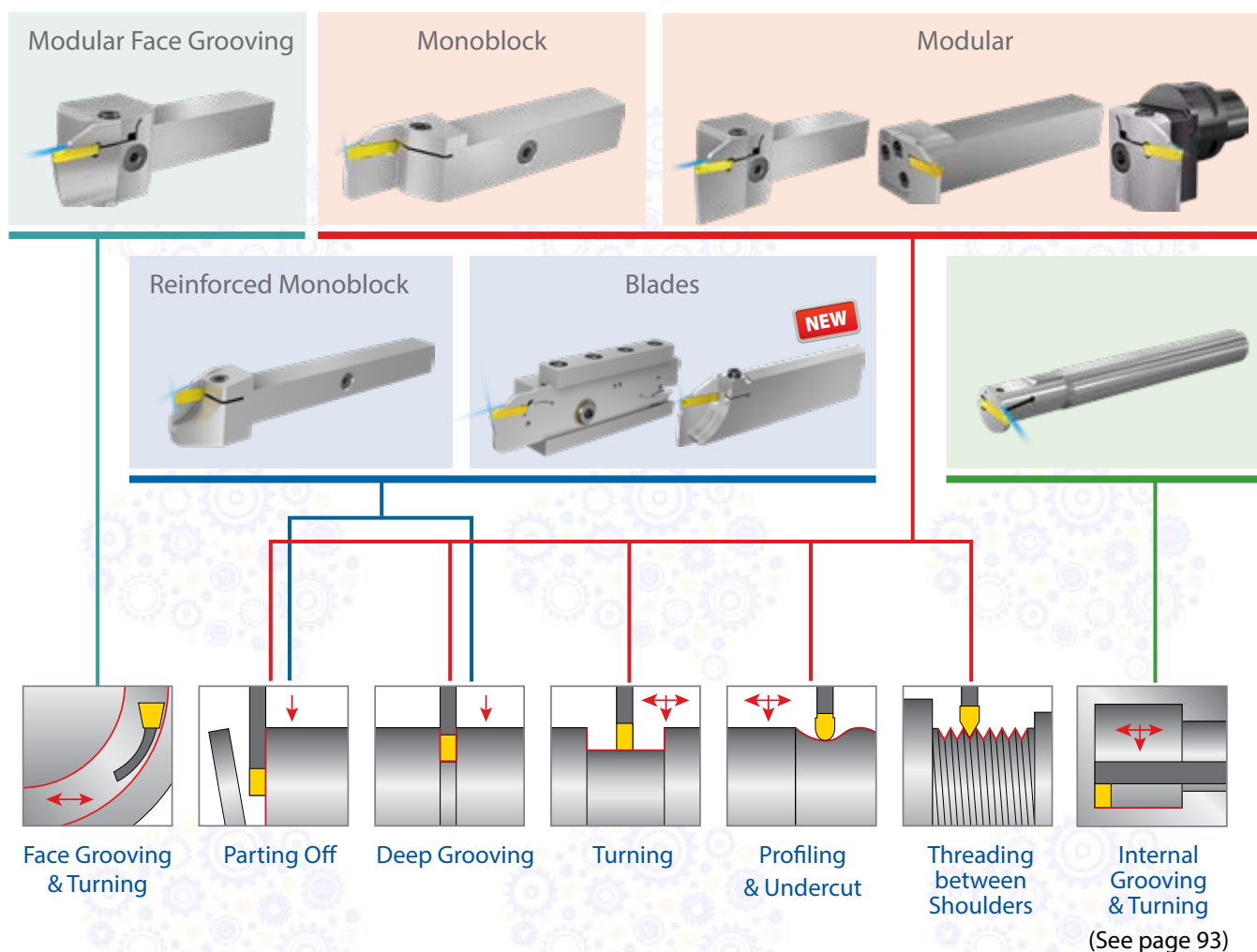

VG-Cut tools cover a wide range of Threading Standards for machining between shoulders and close to the spindle for up to shoulder depth of 10.0 mm.



ТОВ «СМАРТТЕК ІНЖИНІРИНГ», т. +380-50-396-90-96, info@smarttec.com.ua, <https://www.smarttec.com.ua>



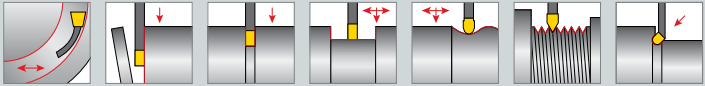

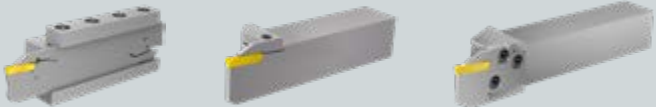

Insert, Tool and Cutting Data Selection Guide

A	Identify the Application																																														
B	Identify the Designated Workpiece Material	<div style="display: flex; justify-content: space-around;"> <div style="background-color: #00a0e3; color: white; padding: 5px; text-align: center;">P Alloy Steel</div> <div style="background-color: #ffcc00; color: black; padding: 5px; text-align: center;">M Stainless Steel</div> <div style="background-color: #cc0000; color: white; padding: 5px; text-align: center;">K Cast Iron</div> <div style="background-color: #00b050; color: white; padding: 5px; text-align: center;">N Non-Ferrous</div> <div style="background-color: #ff9900; color: black; padding: 5px; text-align: center;">S Heat Resistance</div> <div style="background-color: #cccccc; color: black; padding: 5px; text-align: center;">H Hardened Material</div> </div>																																													
C	Designated Chip Former Geometry for Selected Applications		Page 10																																												
D	Designated Carbide Grade for Desired Application	<div style="display: flex; justify-content: space-around;"> <div style="background-color: #cccccc; padding: 5px; text-align: center;">VKG</div> <div style="background-color: #00a0e3; padding: 5px; text-align: center;">VPG</div> <div style="background-color: #ffcc00; padding: 5px; text-align: center;">VMG</div> </div>	Page 11																																												
E	Selecting Insert and Tool as Required by Operation		Pages 23 - 39																																												
F	Cutting Data According to Selected Items	<table border="1" style="font-size: small;"> <tr> <td rowspan="4" style="background-color: #ffcc00;">Stainless Steel</td> <td>15</td> <td>Stainless Steel Cast Ferritic</td> <td>Non Hardened</td> <td>200</td> <td>50-120</td> <td>60-160</td> </tr> <tr> <td>16</td> <td>Stainless Steel Cast Austenitic</td> <td>Hardened</td> <td>330</td> <td>40-100</td> <td>50-140</td> </tr> <tr> <td>17</td> <td>Stainless Steel Cast Austenitic</td> <td>Austenitic</td> <td>200</td> <td>50-120</td> <td>60-160</td> </tr> <tr> <td>18</td> <td>Stainless Steel Cast Austenitic</td> <td>Hardened</td> <td>330</td> <td>40-100</td> <td>50-140</td> </tr> <tr> <td rowspan="3" style="background-color: #cc0000;">Cast Iron</td> <td>28</td> <td>Malleable Cast Iron</td> <td>Ferritic (short chips)</td> <td>130</td> <td>160-240</td> <td>160-280</td> </tr> <tr> <td>29</td> <td>Malleable Cast Iron</td> <td>Pearlitic (long chips)</td> <td>230</td> <td>140-220</td> <td>140-260</td> </tr> <tr> <td>30</td> <td>Malleable Cast Iron</td> <td>Low Tensile Strength</td> <td>180</td> <td>160-240</td> <td>160-280</td> </tr> </table>	Stainless Steel	15	Stainless Steel Cast Ferritic	Non Hardened	200	50-120	60-160	16	Stainless Steel Cast Austenitic	Hardened	330	40-100	50-140	17	Stainless Steel Cast Austenitic	Austenitic	200	50-120	60-160	18	Stainless Steel Cast Austenitic	Hardened	330	40-100	50-140	Cast Iron	28	Malleable Cast Iron	Ferritic (short chips)	130	160-240	160-280	29	Malleable Cast Iron	Pearlitic (long chips)	230	140-220	140-260	30	Malleable Cast Iron	Low Tensile Strength	180	160-240	160-280	Pages 12-19
Stainless Steel	15	Stainless Steel Cast Ferritic		Non Hardened	200	50-120	60-160																																								
	16	Stainless Steel Cast Austenitic		Hardened	330	40-100	50-140																																								
	17	Stainless Steel Cast Austenitic		Austenitic	200	50-120	60-160																																								
	18	Stainless Steel Cast Austenitic	Hardened	330	40-100	50-140																																									
Cast Iron	28	Malleable Cast Iron	Ferritic (short chips)	130	160-240	160-280																																									
	29	Malleable Cast Iron	Pearlitic (long chips)	230	140-220	140-260																																									
	30	Malleable Cast Iron	Low Tensile Strength	180	160-240	160-280																																									



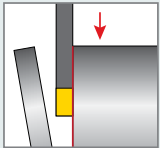

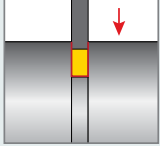

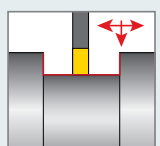

ТОВ «СМАРТТЕК ІНЖИНІРИНГ», Т. +380-50-396-90-96, info@smarttec.com.ua, https://www.smarttec.com.ua

Designated Chip Former Geometry for Parting Off and Grooving

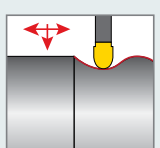
Application	Material Group	Standard Conditions	Extreme Conditions				
 <p>Parting Off</p>	<table border="1"> <tr> <td>P Alloy Steel</td> <td>H Hardened Material</td> </tr> <tr> <td>K Cast Iron</td> <td></td> </tr> </table>	P Alloy Steel	H Hardened Material	K Cast Iron		 <p>GT Recommended choice for machining alloy and stainless steel. Positive rake chip former leads to low cutting forces during cutting. A multifunctional chip former for parting, grooving and turning.</p>	 <p>GP Recommended choice for machining cast iron, for interrupted cuts and for unstable applications where accuracy and overall machining stability are not clear. Reinforced cutting edge for parting off and grooving.</p>
P Alloy Steel	H Hardened Material						
K Cast Iron							
 <p>Grooving</p>	<table border="1"> <tr> <td>M Stainless Steel</td> <td>S Heat Resistance</td> </tr> <tr> <td>N Non-Ferrous</td> <td>P Mild Steel</td> </tr> </table>	M Stainless Steel	S Heat Resistance	N Non-Ferrous	P Mild Steel	 <p>GM/GF Recommended choice for stainless steel. Positive sharp cutting edge decreases build-up on edge for parting off and grooving in low feeds. GM2 Ideal use for parting off and grooving in very low feeds</p>	 <p>GT Recommended choice for machining alloy and stainless steel. Positive rake chip former leads to low cutting forces during cutting, with multifunctional chip former for parting, grooving and turning.</p>
M Stainless Steel	S Heat Resistance						
N Non-Ferrous	P Mild Steel						

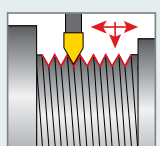
Designated Chip Former Geometry for Turning, Profiling and Threading

Application	Standard Conditions
 <p>Turning</p>	 <p>GT Recommended choice for machining alloy and stainless steel. Positive rake chip former leads to low cutting forces during cutting, with multifunctional chip former for parting off, grooving and turning.</p>
 <p>Profiling</p>	 <p>GR Recommended choice for grooving, undercut and profiling. Round shape geometric for profiling, and positive rake chip former with multifunctional chip control.</p>
 <p>Threading</p>	 <p>RS/LS Varied range of threading standards for machining between shoulders and close to the spindle.</p>



Designated Carbide Grade for Desired Application

Toughness vs. Hardness

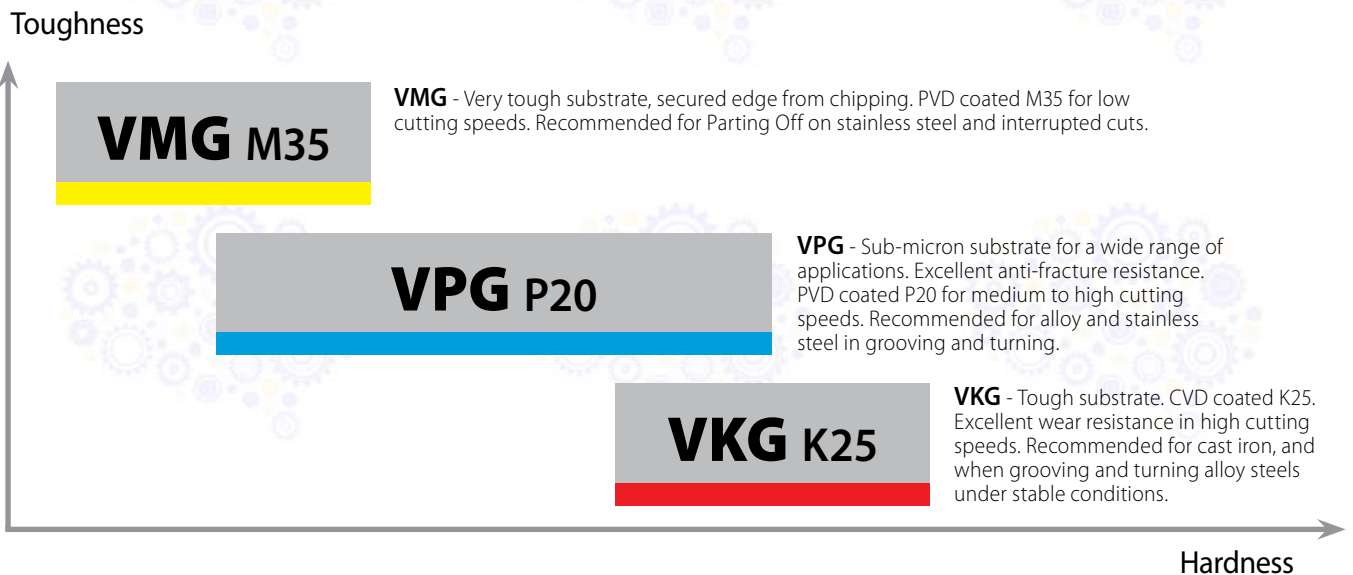

Recommended Carbide Grade for Designated Application

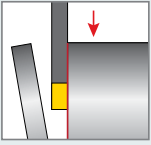
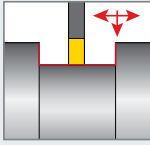
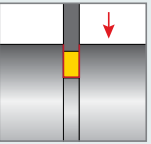
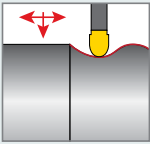
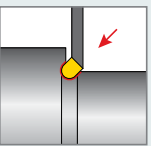
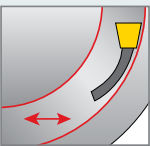
Application	Improved Chipping Resistance	Improved Wear Resistance	Application	Improved Chipping Resistance	Improved Wear Resistance
 Parting Off	VMG M35	VPG P20	 Turning	VPG P20	VKG K25
 Grooving	VPG P20	VKG K25	 Profiling	VPG P20	VKG K25
 Undercut	VMG M35	VPG P20	 Face Turning	VPG P20	VKG K25

ТОВ «СМАРТТЕК ІНЖИНІРИНГ», Т. +380-50-396-90-96, info@smarttec.com.ua, https://www.smarttec.com.ua

Technical Data

Recommended Cutting Speeds Vc [m/min]

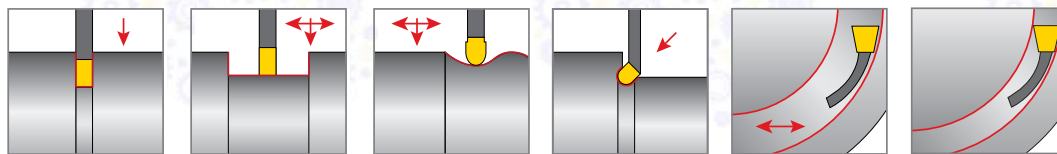

Material Group	Vargus No.	Material	Hardness Brinell HB	Carbide Grade			
				VMG PVD M35	VPG PVD P20	VKG CVD K25	
P Steel	1	Unalloyed Steel	Low Carbon (C=0.1-0.25%)	125	100-160	120-260	120-280
	2		Medium Carbon (C=0.25-0.55%)	150	80-140	90-220	90-250
	3		High Carbon (C=0.55-0.85%)	170	80-140	90-220	90-250
	4	Low Alloy Steel (alloying elements ≤5%)	Non Hardened	180	80-140	90-220	90-250
	5		Hardened	275	50-120	60-150	60-180
	6	High Alloy Steel (alloying elements >5%)	Annealed	200	50-100	90-150	90-250
	7		Hardened	325	40-70	50-100	60-160
	8	Cast Steel	Low Alloy (alloying elements <5%)	200	50-100	90-150	90-250
	9		High Alloy (alloying elements >5%)	225	50-100	60-150	60-180
	M Stainless Steel	11	Stainless Steel Ferritic	Non Hardened	200	50-80	60-160
12		Hardened		330	40-80	50-140	
13		Stainless Steel Austenitic	Austenitic	180	50-80	60-160	
14			Super Austenitic	200	50-80	60-160	
15		Stainless Steel Cast Ferritic	Non Hardened	200	50-80	60-160	
16			Hardened	330	40-80	50-140	
17		Stainless Steel Cast Austenitic	Austenitic	200	50-80	60-160	
18			Hardened	330	40-80	50-140	
K Cast Iron	28	Malleable Cast Iron	Ferritic (short chips)	130		160-200	160-280
	29		Pearlitic (long chips)	230		140-220	140-260
	30	Grey Cast Iron	Low Tensile Strength	180		160-200	160-280
	31		High Tensile Strength	260		100-200	100-240
	32	Nodular Sg Iron	Ferritic	160		100-200	100-240
	33		Pearlitic	260		100-200	100-240
N(K) Non-Ferrous Metals	34	Aluminum Alloys Wrought	Non Aging	60	150-300		
	35		Aged	100	150-250		
	36	Aluminum Alloys Cast	Cast	75	150-300		
	37		Cast & Aged	90	150-300		
	38	Aluminum Alloys Cast Si 13-22%	130	150-250			
	39	Copper and Copper Alloys	Brass	90	150-300		
	40		Bronze And Non Leaded Copper	100	150-300		
S(M) Heat Resistant Material	19	High Temperature Alloys	Annealed (iron based)	200	25-40	30-50	
	20		Aged (iron based)	280	25-35	20-50	
	21		Annealed (nickel or cobalt based)	250	25-35	20-50	
	22		Aged (nickel or cobalt based)	350	25-35	20-50	
	23	Titanium Alloys	Pure 99.5 Ti	400Rm	25-40	30-50	
24	α+β Alloys		1050Rm	25-60	30-70		
H(K) Hardened Material	25	Extra Hard Steel	Hardened & Tempered	45-50HRc		20-40	30-50
	26		51-55HRc		15-30	25-45	

Vc [m/min] for Parting Off

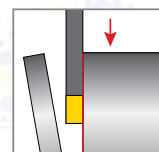

For Parting Off, improved chip forming and chip evacuation; **reduce speed by ≈ 30%**.

For gummy materials, such as stainless steel and heat resistant metals or in case of build up on edge (cold welding), **increase speed by ≈ 20%**.



Technical Data

Recommended Cutting Speeds V_c [m/min] for Threading

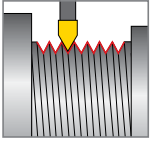

Material Group	Vargus No.	Material	Hardness Brinell HB	Carbide Grade	
				VPG PVD P20	
P Steel	1	Unalloyed Steel	Low Carbon (C=0.1-0.25%)	125	120-260
	2		Medium Carbon (C=0.25-0.55%)	150	90-220
	3		High Carbon (C=0.55-0.85%)	170	90-220
	4	Low Alloy Steel (alloying elements ≤ 5%)	Non Hardened	180	90-220
	5		Hardened	275	60-160
	6		Hardened	350	50-100
	7	High Alloy Steel (alloying elements > 5%)	Annealed	200	90-220
	8		Hardened	325	50-100
	9	Cast Steel	Low Alloy (alloying elements < 5%)	200	90-220
	10		High Alloy (alloying elements > 5%)	225	60-160
M Stainless Steel	11	Stainless Steel Ferritic	Non Hardened	200	60-160
	12		Hardened	330	50-140
	13	Stainless Steel Austenitic	Austenitic	180	60-160
	14		Super Austenitic	200	60-160
	15	Stainless Steel Non Hardened	200	60-160	
	16	Stainless Steel Cast Ferritic	Hardened	330	50-140
	17	Stainless Steel Austenitic	200	60-160	
	18	Stainless Steel Cast Austenitic	Hardened	330	50-140
K Cast Iron	28	Malleable Cast Iron	Ferritic (short chips)	130	160-240
	29		Pearlitic (long chips)	230	140-220
	30	Grey Cast Iron	Low Tensile Strength	180	160-240
	31		High Tensile Strength	260	100-200
	32	Nodular Sg Iron	Ferritic	160	100-200
	33		Pearlitic	260	100-200
N(K) Non-Ferrous Metals	34	Aluminum Alloys Wrought	Non Aging	60	200-450
	35		Aged	100	200-350
	36	Aluminum Alloys	Cast	75	200-450
	37		Cast & Aged	90	200-450
	38		Aluminum Alloys Cast Si 13-22%	130	200-350
	39	Copper and Copper Alloys	Brass	90	200-450
	40		Bronze And Non Lead Copper	100	200-450
S(M) Heat Resistant Material	19	High Temperature Alloys	Annealed (iron based)	200	30-50
	20		Aged (iron based)	280	20-50
	21		Annealed (nickel or cobalt based)	250	20-50
	22		Aged (nickel or cobalt based)	350	20-50
	23	Titanium Alloys	Pure 99.5 Ti	400Rm	30-50
	24		α+β Alloys	1050Rm	30-70
H(K) Hardened Material	25	Extra Hard Steel	Hardened & Tempered	45-50HRC	20-40
	26			51-55HRC	15-30

ТОВ «СМАРТТЕК ІНЖИНІРИНГ», Т. +380-50-396-90-96, info@smarttec.com.ua, https://www.smarttec.com.ua



Feed Rate (f) Starting Point for Deep Grooving, Face Grooving & Parting Off



1.5 mm (GM Only) & 2.0 mm Insert Width

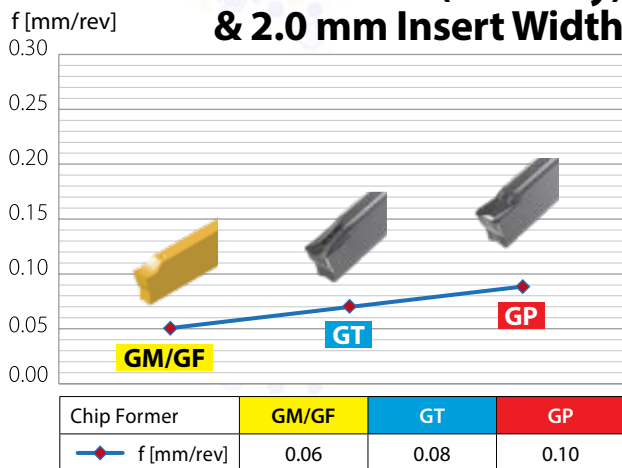

3.0 mm Insert Width

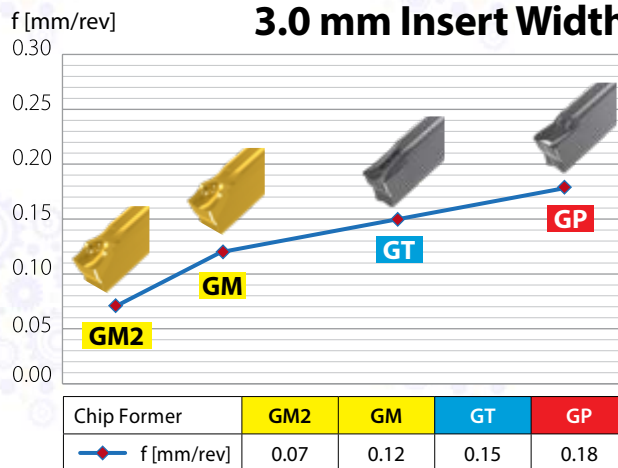

4.0 mm Insert Width

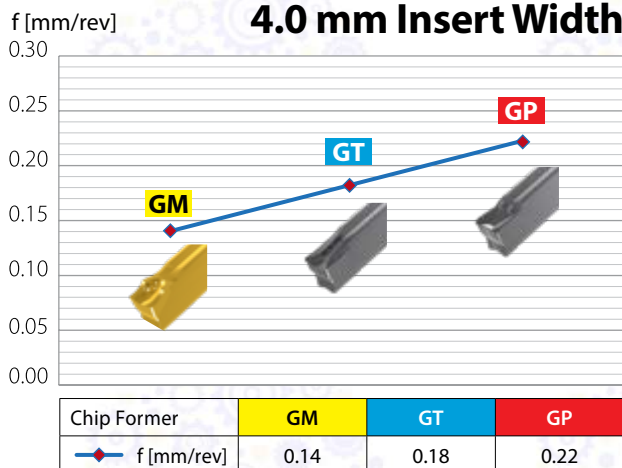

5.0 mm Insert Width

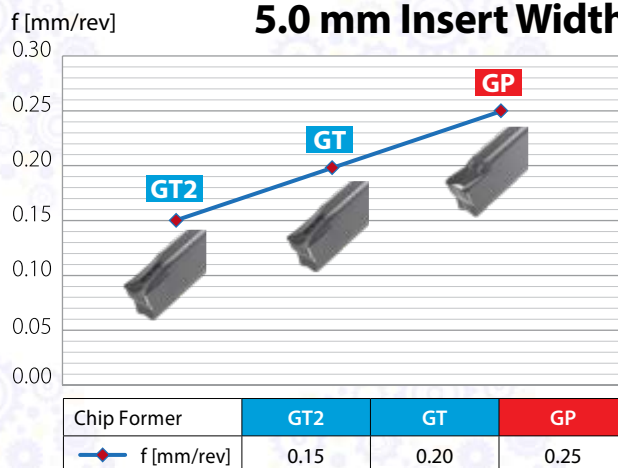

6.0 mm Insert Width

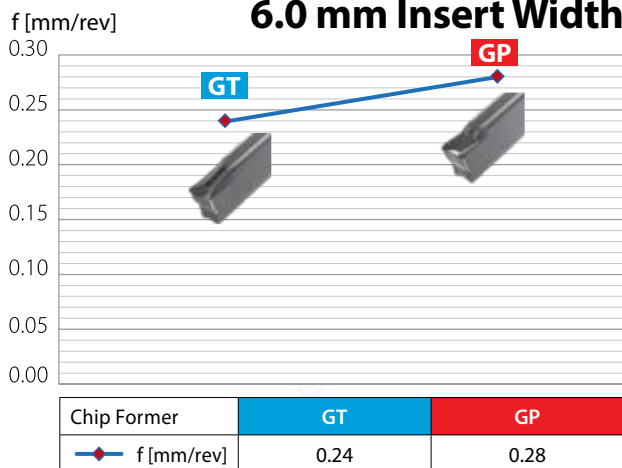

Correct chip forming is essential for chip evacuation. Low feed rates with sufficient chip evacuation improve process stability and tool life. Feed rate should be increased only when improved evacuation is needed to prevent wall scratching or chip entanglement.

For Parting Off, it is recommended to reduce feed rate by 30% while using R / L inserts.

For Parting Off, it is recommended to reduce feed rate by 50% as the insert approaches rotation center. Reduce feed when the insert approaches approx. 3.0 mm diameter.

For better chip evacuation in **Face Grooving**, creating short chips is preferable. It is therefore recommended to work in short intervals (pecking), at a maximum grooving depth of twice the insert width. Taking into consideration the workpiece material and groove diameter, it is recommended to begin the first cut at no longer than the insert's width.



Feed Rate (f) and Depth of Cuts for Axial Turning, Profiling and Face Grooving

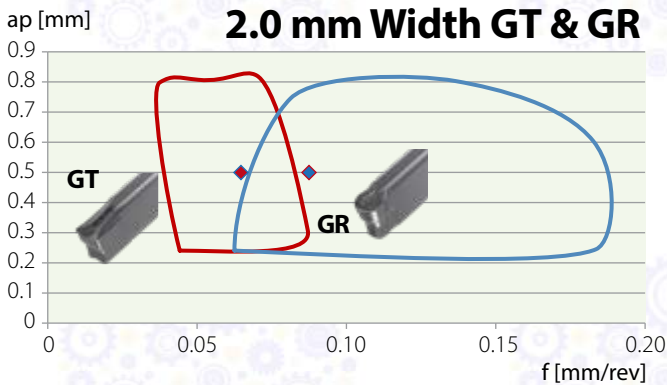
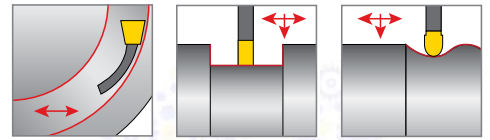

Recommended Starting Point:

	GT 2.0 mm	GR 2.0 mm
ap [mm]	0.50	0.50
f [mm/rev]	0.06	0.08

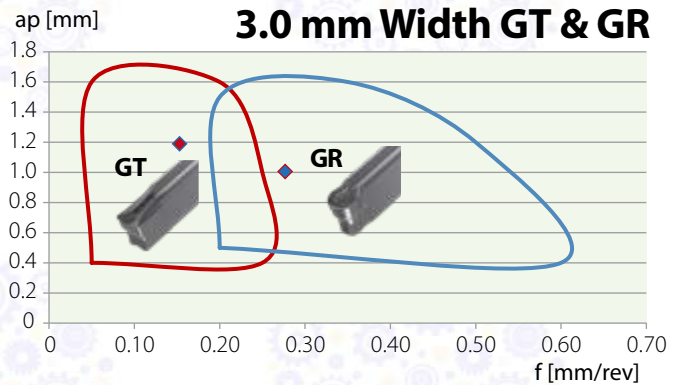

Recommended Starting Point:

	GT 3.0 mm	GR 3.0 mm
ap [mm]	1.20	1.00
f [mm/rev]	0.14	0.25

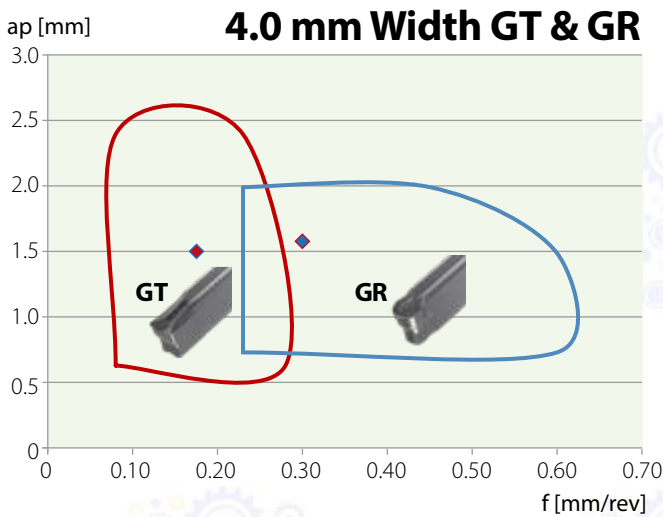

Recommended Starting Point:

	GT 4.0 mm	GR 4.0 mm
ap [mm]	1.50	1.60
f [mm/rev]	0.18	0.30

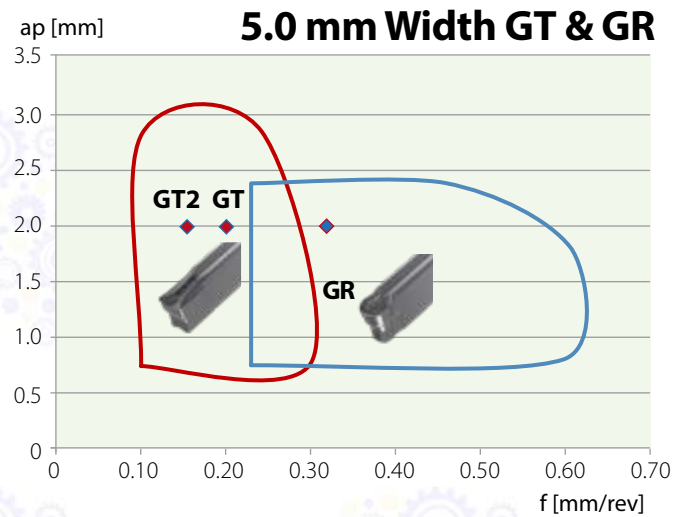

Recommended Starting Point:

	GT2 5.0 mm	GT 5.0 mm	GR 5.0 mm
ap [mm]	2.00	2.00	2.00
f [mm/rev]	0.15	0.20	0.32

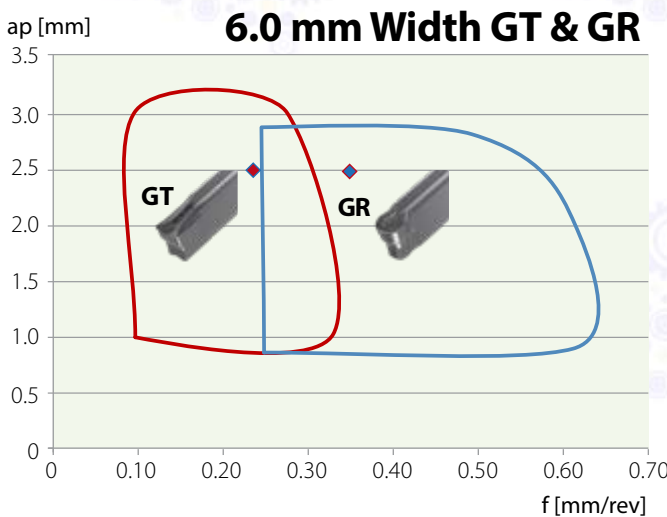

Recommended Starting Point:

	GT 6.0 mm	GR 6.0 mm
ap [mm]	2.50	2.50
f [mm/rev]	0.24	0.35

ТОВ «СМАРТТЕК ІНЖИНІРИНГ», Т. +380-50-396-90-96, info@smarttec.com.ua, https://www.smarttec.com.ua



Radial Groove and Turn Machining Recommendations

Roughing:

Method 1:

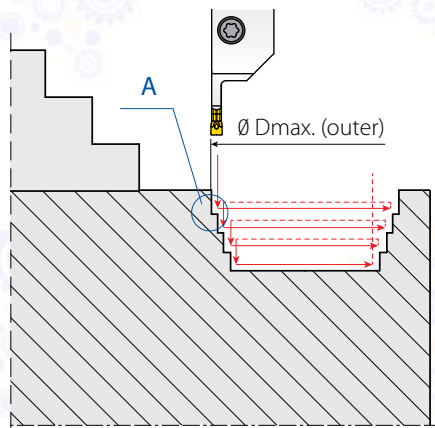

Figure A

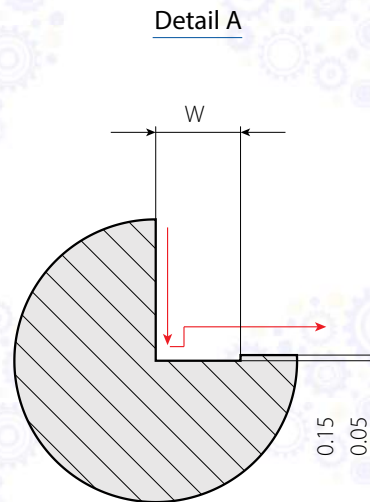

Figure B

1. Start by radial grooving close to spindle.
2. Radial retract back by 0.10 mm (see Figure B), followed by longitudinal turning from spindle.
3. Radial retract by 0.10 mm and return towards spindle.
4. Repeat the above cycle (1, 2 & 3), each time deeper into the workpiece, with an average grooving depth 0.2-0.45mm insert width.
5. Keep about 0.4 mm of additional material on workpiece, which will be removed in the finishing operation as recommended in the next page.

Method 2:

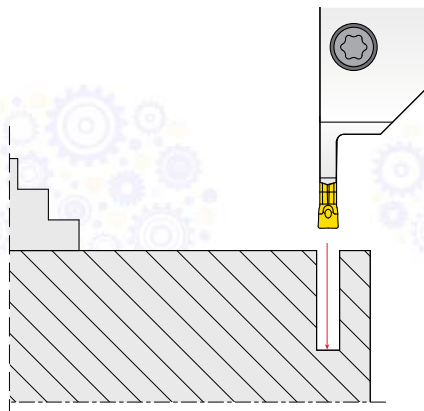

Figure A

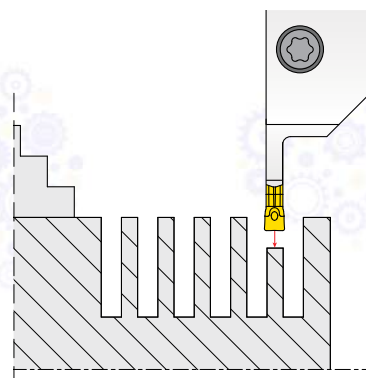

Figure B

1. Start by radial grooving far from spindle (Figure A), making sure that the material is always being machined at the center of the insert.
2. Continue to work towards spindle, leaving excess material between each groove. The excess material should not be wider than the insert's width minus 2 times the radius: $W-Rx2 = \text{max. grooving width}$.
3. Radial groove the excess material (Figure B).

See the following page for Finishing Recommendations.

Radial Groove and Turn Machining Recommendations

Finishing:

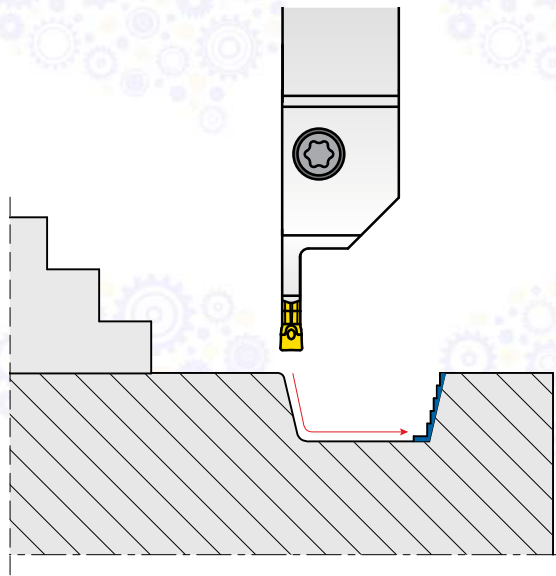

Figure A

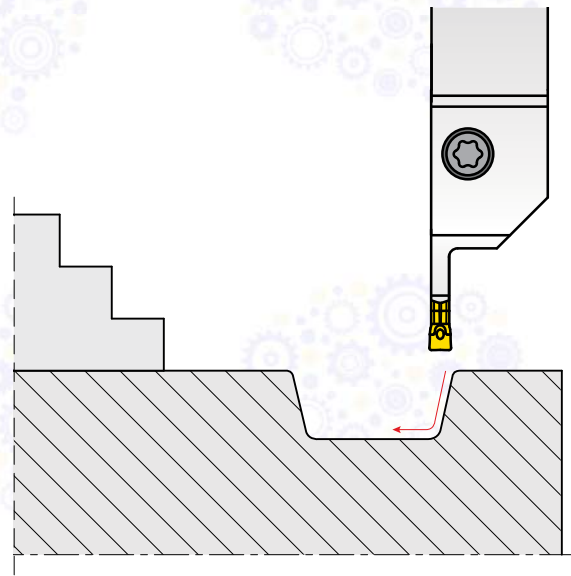

Figure B

1. Start the profiling operation close to spindle, and towards the workpiece's inner diameter. Generate the desired radius followed by longitudinal turning close to the tangential point of the second inner radius (Figure A).
2. Start the Profiling operation far from spindle, and towards the workpiece's inner diameter. Generate the desired radius as needed (Figure B).

Face Groove and Turn Machining Recommendations

Roughing:

Method 1:

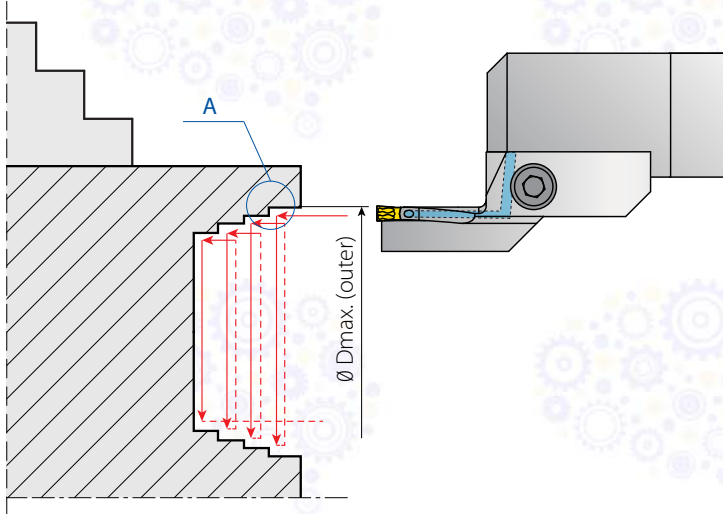

Figure A

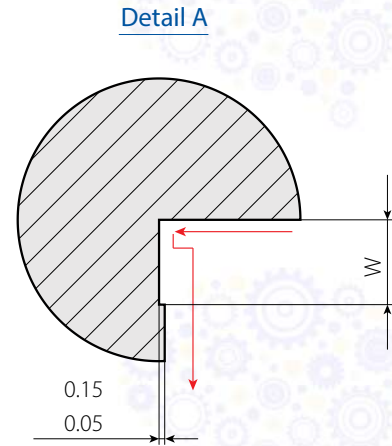

Figure B

1. Start by face grooving close to outer diameter.
2. Retract back by 0.10 mm (see Figure B), followed by face turning towards the center.
3. Axial retract away from the workpiece for about 0.10 mm.
4. Repeat the above cycle (1, 2 & 3), each time deeper into the workpiece, with average grooving depth of 0.2 - 0.45 insert width.
5. Keep about 0.4 mm of additional material on workpiece, which will be removed in the finishing operation as recommended below.

Method 2:

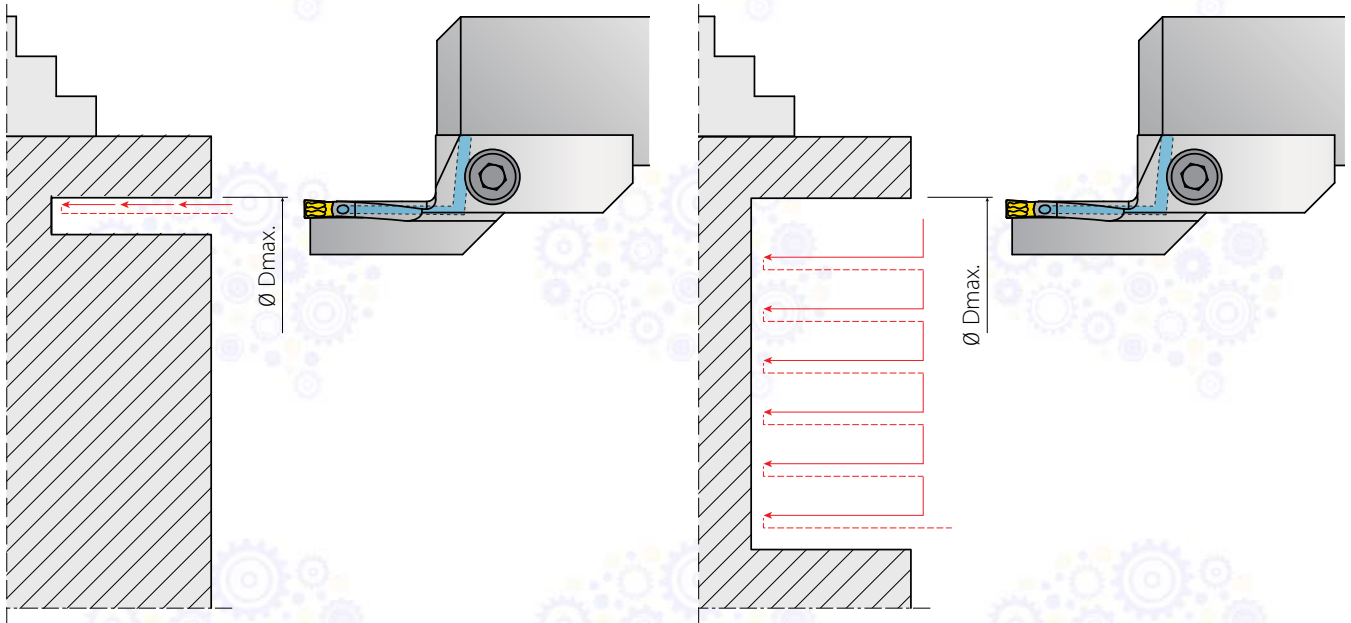

Figure A

Figure B

1. Start by face grooving close to outer diameter (Figure A). Work in short intervals (pecking) at maximum grooving depth of twice the insert width.
2. Follow this by face grooving towards the center of the workpiece as required for covering the entire pocket shape (Figure B). Each additional groove width should be smaller than the insert width by approx. 0.3 mm.
3. Only the first groove (Figure A) is done in short intervals (pecking) for better chip evacuation. Other grooves can be done continuously based on recommended feeds for the application.
4. Recommended chip forming for Alloy Steel is GP. For Stainless Steel please use GT.

See the following page for Finishing Recommendations.

Face Groove and Turn Machining Recommendations

Finishing:

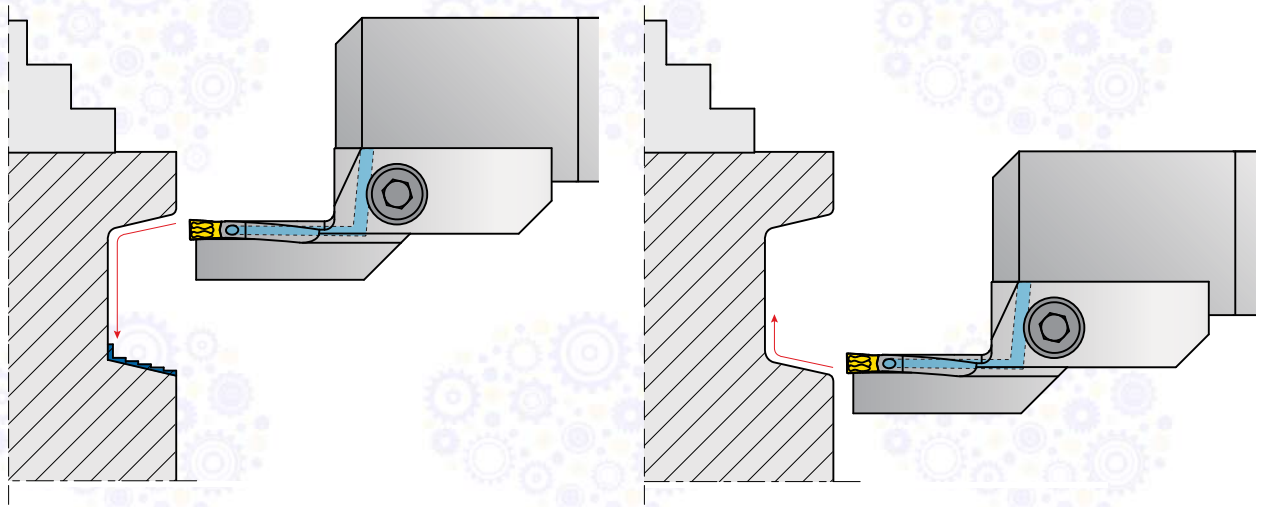

1. Start the Profiling operation from the outer diameter of the workpiece and work in. Generate the desired radius followed by the face turning operation close to the tangential point of the inner radius.
2. Start the Profiling operation from the inner diameter towards the bottom of the workpiece, generate the desired radius as needed.

Selecting the Correct Face Grooving Module

VG Cut Ordering Code Example: **VGFR-4860-T24-4C**

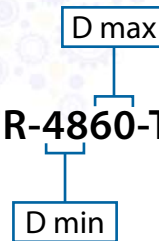

Wrong Support

Correct Support

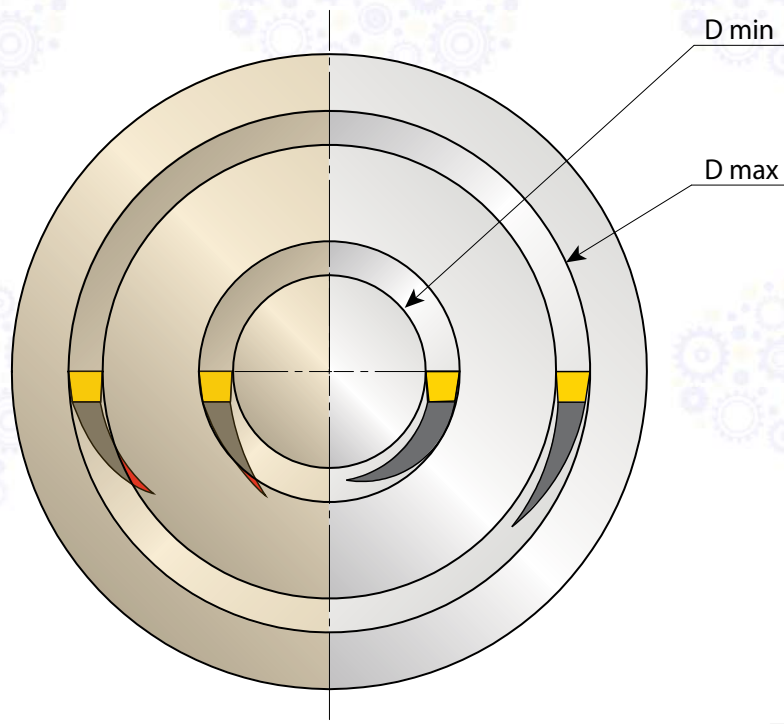

User Guide for Modular System

Choosing the Correct Holder for the Application (Body + Module):

* High pressure coolant system shown

Parallel Right Tools

Right Body



Radial

Face



Right Module

Left Module

Parallel Left Tools

Left Body

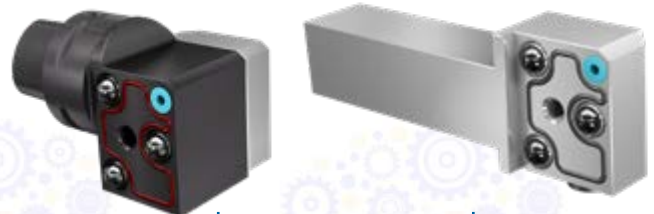

Radial

Face



Left Module

Right Module

90° Right Tools

Right Body



Radial

Face



Left Module

Right Module

90° Left Tools

Left Body



Radial

Face



Right Module

Left Module

High Pressure Coolant Accessories and Spare Parts

Image	Ordering Code	Item Number	Relevant Tools
	Tube Connector 25-6P	013-00941	VG-Cut Blade Holders See page 38
	Angled Fitting G1_8x6P	013-00947	VG-Cut / GrooVical Modular Bodies See page 43
	Straight Fitting G1_8x6P	013-00942	VG-Cut / GrooVical V-Cap Bodies See page 44
	Plug G1/8"P	013-00948	VG-Cut Blade Holders See page 38
	Plug DIN 916 GALV M6x8P	013-00940	
	Coolant Sleeve	013-00946	VG-Cut / GrooVical Modular Bodies See page 43
	O-RING Body Seal	013-00944	VG-Cut / GrooVical V-Cap Bodies See page 44



VG-Cut Inserts

Parting Off & Deep Grooving - Double Sided Inserts (1.5 - 6.0 mm).....	24
Parting Off & Deep Grooving - Single Sided Inserts (2.0 - 4.0 mm).....	26
Turning & Profiling (2.0 - 6.0 mm).....	27
Threading (3.0 mm).....	28



VG-Cut Inserts - Ordering Code System

VG	D	3.00	020	6R	GP	VPG
1	2	3	4	5	6	7

1 – Line Name VG - VG-Cut	2 – Number of Cutting Corners D - Double S - Single	3 – Insert Width 1.5, 2.0, 3.0, 4.0, 5.0, 6.0 mm	4 – Corner Radius 0.20 mm Threading Standard
5 – RH or LH (for Parting Off) 4, 6, 15 Deg. RH or LH None - Neutral	5 – RH or LH (for Threading) RH Helix LH Helix	6 – Top Rake Geometry GP, GM, GM2, GT, GT2, GR RS - Close to right shoulder LS - Close to left shoulder	7 – Carbide Grade VPG, VMG, VKG

ТОВ «СМАРТТЕК ІНЖИНІРИНГ», Т. +380-50-396-90-96, info@smarttec.com.ua, https://www.smarttec.com.ua

Parting Off & Deep Grooving - Double Sided Inserts

1.5 - 6.0 mm Width

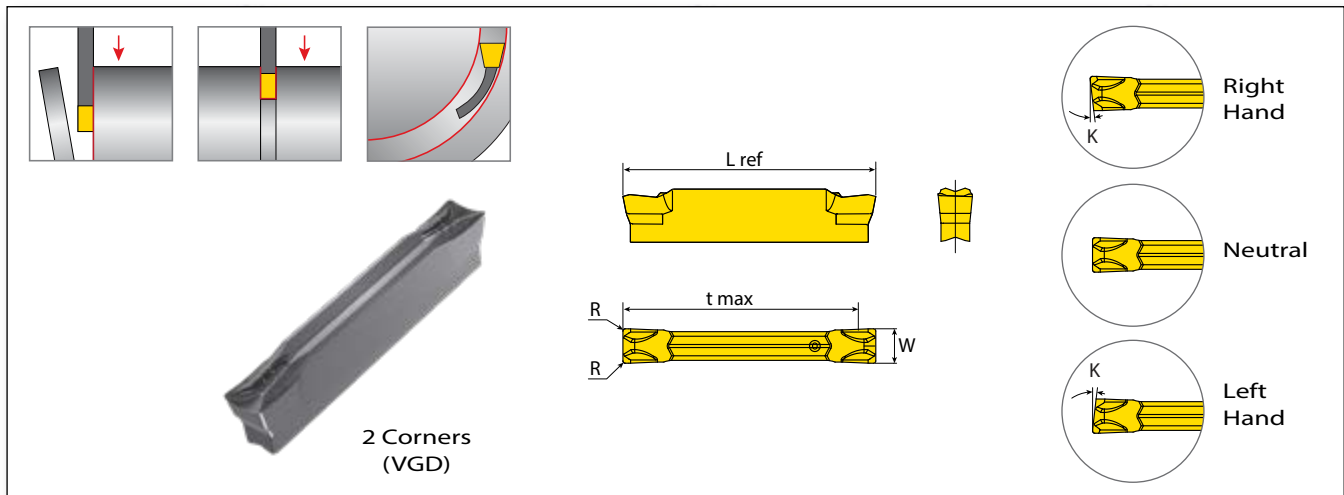

	Pocket Size	Ordering Code	Dimensions mm					Feed Range (mm/rev)	Grade			
			W ^{±0.04}	R	t max	K°	L ref		VPG	VMG	VKG	
Positive cutting edge, for small parts, thin wall pipes & soft materials	GF	2	VGD2.00-015-6R-GF	2.00	0.15	20.0	6.0	22.0	0.03 - 0.10	•	○	○
		2	VGD2.00-015-6L-GF	2.00	0.15	20.0	6.0	22.0	0.03 - 0.10	•	○	○
		2	VGD2.00-020-GF	2.00	0.20	20.0	0.0	22.0	0.03 - 0.10	•	•	○
		2	VGD2.00-020-15R-GF	2.00	0.20	20.0	15.0	22.0	0.03 - 0.08	•	○	○
		2	VGD2.00-020-15L-GF	2.00	0.20	20.0	15.0	22.0	0.03 - 0.08	•	○	○
Positive sharp cutting edge, for low feed & speed	GM	1.5	VGD1.50-012-GM	1.50	0.12	20.0	0.0	22.0	0.03 - 0.10	•	•	-
		1.5	VGD1.50-003-15R-GM	1.50	0.03	20.0	15.0	22.0	0.03 - 0.06	○	•	-
		1.5	VGD1.50-003-15L-GM	1.50	0.03	20.0	15.0	22.0	0.03 - 0.06	○	•	-
		2	VGD2.00-015-GM	2.00	0.15	20.0	0.0	22.0	0.03 - 0.10	•	○	○
		3	VGD3.00-015-GM	3.00	0.15	20.0	0.0	22.0	0.06 - 0.16	•	○	•
		3	VGD3.00-030-GM	3.00	0.30	20.0	0.0	22.0	0.08 - 0.22	•	•	•
		3	VGD3.00-020-6R-GM	3.00	0.20	20.0	6.0	22.0	0.05 - 0.16	•	•	○
		3	VGD3.00-020-6L-GM	3.00	0.20	20.0	6.0	22.0	0.05 - 0.16	•	•	○
		3	VGD3.00-018-15R-GM	3.00	0.18	20.0	15.0	22.0	0.04 - 0.12	○	•	○
		3	VGD3.00-018-15L-GM	3.00	0.18	20.0	15.0	22.0	0.04 - 0.12	○	•	○
		3	VGD3.00-030-GM2	3.00	0.30	20.0	0.0	22.0	0.04 - 0.12	○	•	○
		4	VGD4.00-040-GM	4.00	0.40	23.0	0.0	25.0	0.08 - 0.25	•	•	○
Multipurpose geometry, for general use	GT	2	VGD2.00-020-GT	2.00	0.20	20.0	0.0	22.0	0.03 - 0.12	•	○	•
		3	VGD3.00-030-GT	3.00	0.30	20.0	0.0	22.0	0.05 - 0.15	•	○	•
		4	VGD4.00-020-GT	4.00	0.20	23.0	0.0	25.0	0.05-0.15	•	○	○
		4	VGD4.00-040-GT	4.00	0.40	23.0	0.0	25.0	0.05 - 0.18	•	○	•
		4	VGD4.00-080-GT	4.00	0.80	23.0	0.0	25.0	0.05 - 0.22	•	○	○
		5	VGD5.00-040-GT	5.00	0.40	23.0	0.0	25.0	0.08 - 0.25	•	○	•
		5	VGD5.00-080-GT2	5.00	0.80	23.0	0.0	25.0	0.06 - 0.22	•	○	○
		6	VGD6.00-040-GT	6.00	0.40	23.0	0.0	25.0	0.10 - 0.25	•	○	•
6	VGD6.00-080-GT	6.00	0.80	23.0	0.0	25.0	0.10 - 0.28	•	○	○		
Round multipurpose geometry for profiling & undercut	GR	2	VGD2.00-100-GR	2.00	1.00	18.0	0.0	22.0	0.03 - 0.12	•	○	•
		3	VGD3.00-150-GR	3.00	1.50	18.0	0.0	22.0	0.05 - 0.15	•	○	•
		4	VGD4.00-200-GR	4.00	2.00	20.0	0.0	25.0	0.05 - 0.18	•	○	•
		5	VGD5.00-250-GR	5.00	2.50	20.0	0.0	25.0	0.06 - 0.20	•	○	○
		6	VGD6.00-300-GR	6.00	3.00	20.0	0.0	25.0	0.06 - 0.20	•	○	•

• In stock • Available upon request

ТОВ «СМАРТТЕК ІНЖИНІРИНГ», т. +380-50-396-90-96, info@smarttec.com.ua, https://www.smarttec.com.ua



СМАРТТЕК
РОЗУМНІ ТЕХНОЛОГІЇ

Parting Off & Deep Grooving - Double Sided Inserts (con't)

2.0 - 6.0 mm Width

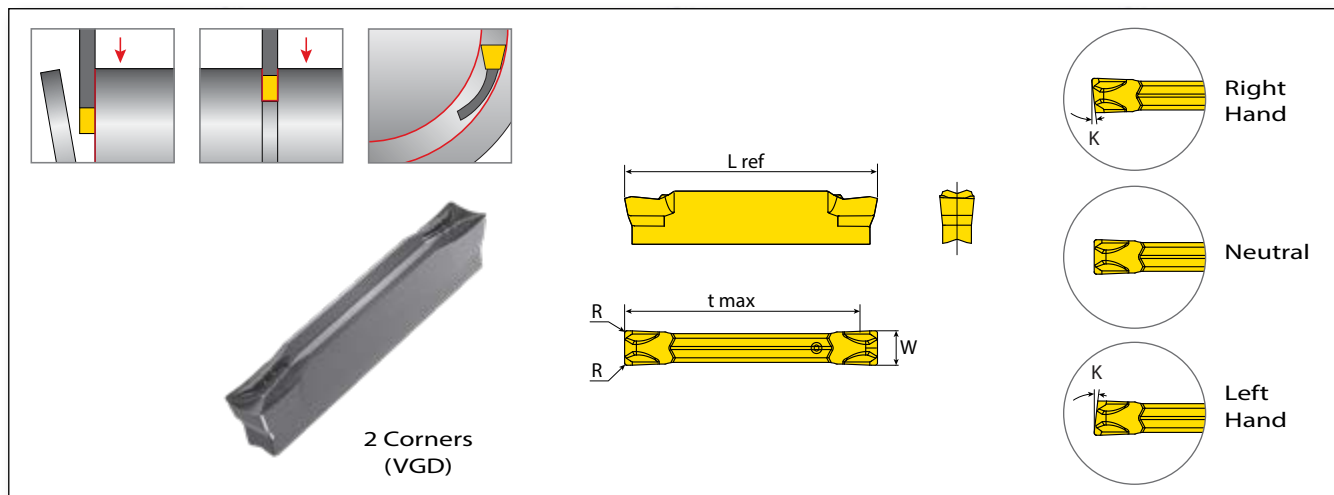

Pocket Size	Ordering Code	Dimensions mm					Feed Range (mm/rev)	Grade		
		W ^{±0.04}	R	t max	K°	L ref		VPG	VMG	VKG
2	VGD2.00-020-GP	2.00	0.20	20.0	0.0	22.0	0.03 - 0.14	•	•	•
2	VGD2.00-015-6R-GP	2.00	0.15	20.0	6.0	22.0	0.04 - 0.12	◦	•	◦
2	VGD2.00-015-6L-GP	2.00	0.15	20.0	6.0	22.0	0.04 - 0.12	◦	•	◦
2	VGD2.00-020-15R-GP	2.00	0.20	20.0	15.0	22.0	0.03 - 0.10	•	•	◦
2	VGD2.00-020-15L-GP	2.00	0.20	20.0	15.0	22.0	0.03 - 0.10	◦	•	◦
3	VGD3.00-020-GP	3.00	0.20	20.0	0.0	22.0	0.06 - 0.20	•	•	•
3	VGD3.00-015-6R-GP	3.00	0.15	20.0	6.0	22.0	0.06 - 0.16	•	•	•
3	VGD3.00-015-6L-GP	3.00	0.15	20.0	6.0	22.0	0.06 - 0.16	•	•	◦
4	VGD4.00-030-GP	4.00	0.30	23.0	0.0	25.0	0.08 - 0.24	•	•	•
4	VGD4.00-020-4R-GP	4.00	0.20	23.0	4.0	25.0	0.06 - 0.22	◦	•	◦
4	VGD4.00-020-4L-GP	4.00	0.20	23.0	4.0	25.0	0.06 - 0.22	◦	•	◦
5	VGD5.00-040-GP	5.00	0.40	23.0	0.0	25.0	0.08 - 0.28	•	◦	•
6	VGD6.00-040-GP	6.00	0.40	23.0	0.0	25.0	0.10 - 0.30	•	•	•

Blunt reinforced cutting edge for high feed & speed



• In stock ◦ Available upon request

ТОВ «СМАРТТЕК ІНЖИНІРИНГ», Т. +380-50-396-90-96, info@smarttec.com.ua, https://www.smarttec.com.ua

Parting Off & Deep Grooving - Single Sided Inserts

2.0 - 4.0 mm Width

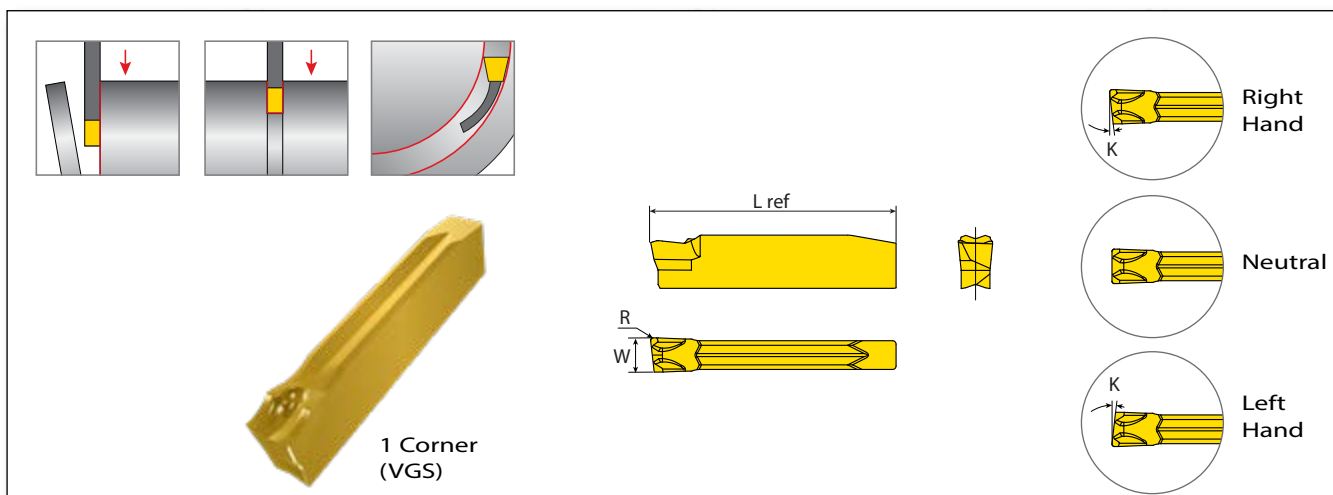

	Pocket Size	Ordering Code	Dimensions mm					Feed Range (mm/rev)	Grade				
			W ±0.04	R	t max	K°	L ref		VPG	VMG	VKG		
Positive cutting edge, for small parts, thin wall pipes & soft materials	GF		2	VGS2.00-015-6R-GF	2.00	0.15	∞	6.0	21.3	0.03 - 0.10	○	●	○
			2	VGS2.00-015-6L-GF	2.00	0.15	∞	6.0	21.3	0.03 - 0.10	○	●	○
Positive sharp cutting edge, for low feed & speed	GM		3	VGS3.00-020-GM	3.00	0.20	∞	0.0	22.0	0.08 - 0.22	●	●	○
			3	VGS3.00-020-6R-GM	3.00	0.20	∞	6.0	21.3	0.05 - 0.16	○	●	○
			4	VGS4.00-040-GM	4.00	0.40	∞	0.0	25.0	0.08 - 0.25	●	●	○
			4	VGS4.00-040-4R-GM	4.00	0.40	∞	4.0	24.3	0.06 - 0.18	○	●	○
			4	VGS4.00-040-4L-GM	4.00	0.40	∞	4.0	24.3	0.06 - 0.18	○	●	○
Blunt reinforced cutting edge for high feed & speed	GP		3	VGS3.00-020-GP	3.00	0.20	∞	0.0	22.0	0.06 - 0.20	●	●	○
			3	VGS3.00-020-6R-GP	3.00	0.20	∞	6.5	21.3	0.06 - 0.16	○	●	○
			3	VGS3.00-020-6L-GP	3.00	0.20	∞	6.5	21.3	0.06 - 0.16	○	●	○
			4	VGS4.00-030-GP	4.00	0.30	∞	0.0	25.0	0.08 - 0.24	●	●	○
			4	VGS4.00-030-4R-GP	4.00	0.30	∞	4.0	24.3	0.06 - 0.22	○	●	○
			4	VGS4.00-030-4L-GP	4.00	0.30	∞	4.0	24.3	0.06 - 0.22	○	●	○



● In stock ○ Available upon request

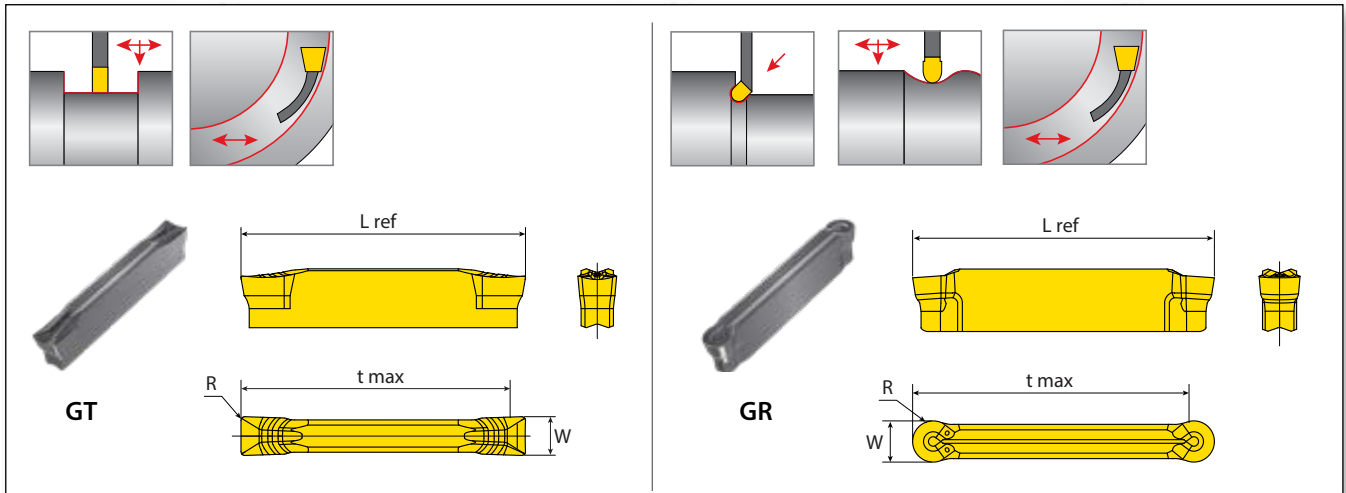

Turning & Profiling

2.0 - 6.0 mm Width



	Pocket Size	Ordering Code	Dimensions mm					Feed Range (mm/rev)	Grade		
			W±0.04	R	t max	K°	L ref		VPG	VMG	VKG
Positive rake chip former with multifunctional chip control. Low cutting forces during cutting. 	2	VGD2.00-020-GT	2.00	0.20	20.0	0.0	22.0	0.03 - 0.12	•	○	•
	3	VGD3.00-030-GT	3.00	0.30	20.0	0.0	22.0	0.05 - 0.15	•	○	•
	4	VGD4.00-020-GT	4.00	0.20	23.0	0.0	25.0	0.05-0.15	•	○	○
	4	VGD4.00-040-GT	4.00	0.40	23.0	0.0	25.0	0.05 - 0.18	•	○	•
	4	VGD4.00-080-GT	4.00	0.80	23.0	0.0	25.0	0.05 - 0.22	•	○	○
	5	VGD5.00-040-GT	5.00	0.40	23.0	0.0	25.0	0.08 - 0.25	•	○	•
	5	VGD5.00-080-GT2	5.00	0.80	23.0	0.0	25.0	0.06 - 0.22	•	○	○
	6	VGD6.00-040-GT	6.00	0.40	23.0	0.0	25.0	0.10 - 0.25	•	○	•
	6	VGD6.00-080-GT	6.00	0.80	23.0	0.0	25.0	0.10 - 0.28	•	○	○
Round shape geometric design for profiling. Positive rake chip former and multifunctional chip control for undercut and profiling. 	2	VGD2.00-100-GR	2.00	1.00	18.0	0.0	22.0	0.03 - 0.12	•	○	•
	3	VGD3.00-150-GR	3.00	1.50	18.0	0.0	22.0	0.05 - 0.15	•	○	•
	4	VGD4.00-200-GR	4.00	2.00	20.0	0.0	25.0	0.05 - 0.18	•	○	•
	5	VGD5.00-250-GR	5.00	2.50	20.0	0.0	25.0	0.06 - 0.20	•	○	○
	6	VGD6.00-300-GR	6.00	3.00	20.0	0.0	25.0	0.06 - 0.20	•	○	•

• In stock ○ Available upon request

ТОВ «СМАРТТЕК ІНЖИНІРИНГ», Т. +380-50-396-90-96, info@smarttec.com.ua, https://www.smarttec.com.ua

Threading

3.0 mm Width

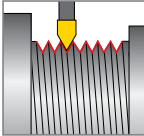

RS/LS Varied range of threading standards for machining between shoulders and close to spindle.

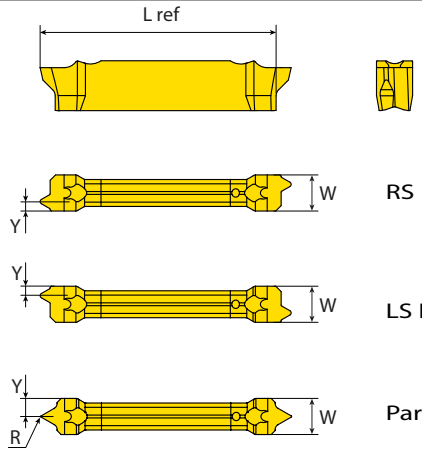
To be used with Monoblock tools (VGE..T08 or T12) or reinforced monoblock tools (PH) only.

Partial Profile 60°

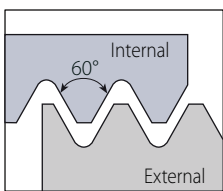

Pocket Size	Ordering Code	Dimensions mm					No. of Passes	Helix Deg	Grade	Min. Thread Diameter
		W ref	Pitch mm	R	Y	L ref				
3	VGD3.0A60RH	3.00	0.5-1.5	0.05	1.68	21.9	5 - 8	1.5°	●	Partial Profile A60

● In stock ● Available upon request

Partial Profile 55°

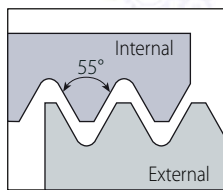

Pocket Size	Ordering Code	Dimensions mm					No. of Passes	Helix Deg	Grade	Min. Thread Diameter
		W ref	Pitch TPI	R	Y	L ref				
3	VGD3.0A55RH	3.00	48-16	0.05	1.68	21.9	5 - 8	1.5°	●	Partial Profile A55

● In stock ● Available upon request

ISO Metric

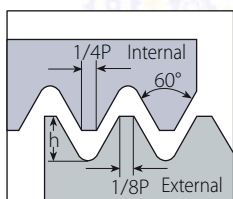

Defined by: R262 (DIN 13)
Tolerance class: 6g

Pocket Size	Ordering Code	Dimensions mm					No. of Passes	Helix Deg	Grade	Min. Thread Diameter
		W ref	Pitch mm	h min	Y	L ref				
3	VGD3.0ISO0.4RH-LS	3.00	0.40	0.25	0.37	21.9	3 - 7	4°	●	M2x0.4
3	VGD3.0ISO0.50RH-RS/LS		0.50	0.31	0.53		5 - 7	●	M3x0.5	
3	VGD3.0ISO0.70RH-RS/LS		0.70	0.43	0.64		5 - 8	●	M4x0.7 Coarse	
3	VGD3.0ISO0.75RH-RS/LS		0.75	0.46	0.64		5 - 8	●	M5x0.75	
3	VGD3.0ISO0.75LH-LS		0.75	0.46	0.64		5 - 8	●	M5x0.75	
3	VGD3.0ISO0.80RH-RS/LS		0.80	0.49	0.64		5 - 8	●	M5x0.8 Coarse	
3	VGD3.0ISO1.00RH-RS/LS		1.00	0.61	0.74		5 - 9	2.5°	●	M6x1
3	VGD3.0ISO1.25RH-RS/LS		1.25	0.77	0.85		6 - 10	●	M8x1.25	
3	VGD3.0ISO1.50RH-RS/LS		1.50	0.92	1.10		7 - 12	●	M10x1.5 Coarse	
3	VGD3.0ISO1.75RH-RS/LS		1.75	1.07	1.20		8 - 14	●	M12x1.75 Coarse	
3	VGD3.0ISO2.00RH-RS/LS		2.00	1.23	1.30		9 - 14	●	M16x2.0 Coarse	
3	VGD3.0ISO2.50RH-RS/LS		2.50	1.53	1.55		8 - 14	●	M18x2.5 Coarse	

● In stock ● Available upon request



Threading

3.0 mm Width (con't)



RS/LS Varied range of threading standards for machining between shoulders and close to spindle.

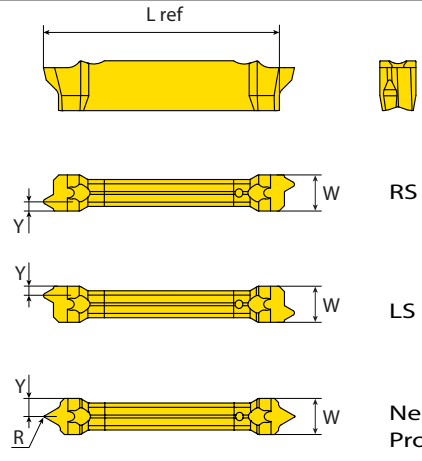

To be used with Monoblock tools (VGE..T08 or T12) or reinforced monoblock tools (PH) only.

American UN

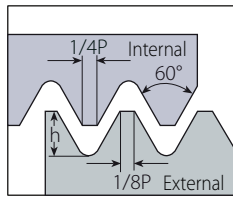

Defined by: ANSI B1.1:74
Tolerance class: 2A

Pocket Size	Ordering Code	Dimensions mm					No. of Passes	Helix Deg	Grade	Min. Thread Diameter
		W ref	Pitch TPI	h min	Y	L ref				
3	VGD3.0UN80RH-RS/LS		80	0.18	0.35	3 - 5	4°	●	No.0-80UNF	
3	VGD3.0UN72RH-LS		72	0.22	0.38	3 - 5			No.1-72UNF	
3	VGD3.0UN56RH-RS/LS		56	0.28	0.40	3 - 6			No.2-56UNC	
3	VGD3.0UN40RH-RS/LS		40	0.39	0.60	3 - 7	2.5°	●	No.4-40UNC	
3	VGD3.0UN32RH-RS/LS		18	0.87	0.93	5 - 8			5/32"-32UNC	
3	VGD3.0UN28RH-RS/LS		28	0.56	0.71	5 - 9			3/16"-28UNC	
3	VGD3.0UN24RH-RS/LS	3.00	24	0.65	0.77	5 - 9	2.5°	●	7/32"-24UNC	
3	VGD3.0UN20RH-RS/LS		20	0.78	0.86	6 - 10			1/4"-20UNC	
3	VGD3.0UN18RH-RS/LS		18	0.87	0.93	7 - 12			5/16"-18UNC	
3	VGD3.0UN18LH-LS		18	0.87	0.93	7 - 12	2.5°	●	5/16"-18UNC	
3	VGD3.0UN16RH-RS/LS		16	0.97	1.10	7 - 12			3/8"-16UNC	
3	VGD3.0UN14RH-RS/LS		14	1.11	1.09	8 - 14			7/16"-14UNC	
3	VGD3.0UN12RH-RS/LS		12	1.30	1.30	8 - 14	2.5°	●	9/16"-14UNC	

● In stock ○ Available upon request | LH Helix threads available upon request

Whitworth

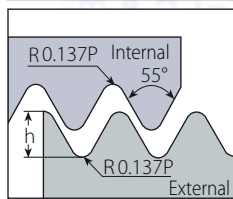

Defined by: B.S.84:1956,
DIN 259, ISO228/1:1982
Tolerance class:
Medium class A

Pocket Size	Ordering Code	Dimensions mm					No. of Passes	Helix Deg	Grade	Min. Thread Diameter
		W ref	Pitch TPI	h min	Y	L ref				
3	VGD3.0W36RH-LS		36	0.86	0.95	5 - 8	2.5°	●		
3	VGD3.0W32RH-LS		32	1.16	1.15	5 - 8				
3	VGD3.0W26RH-LS	3.00	26	1.48	1.68	5 - 8				
3	VGD3.0W19RH-RS/LS		19	0.45	0.60	7 - 12	2.5°	●	1/2"-19BSW	
3	VGD3.0W14RH-RS/LS		14	0.51	0.60	8 - 14			1/2"-14BSW	
3	VGD3.0W11RH/LH		11	0.63	0.75	8 - 14			5/8"-11BSW	

● In stock ○ Available upon request | LH Helix threads available upon request

NPT

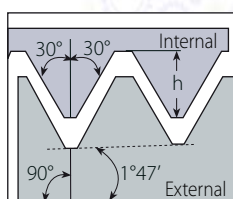

Defined by:
AS B2.1:1968
Tolerance class: Standard NPT

Pocket Size	Ordering Code	Dimensions mm					No. of Passes	Helix Deg	Grade	Min. Thread Diameter
		W ref	Pitch TPI	h min	Y	L ref				
3	VGD3.0NPT18RH-RS/LS		18	1.01	1.20	7 - 12	1.5°	●	1/4"-18NPT	
3	VGD3.0NPT14RH-RS/LS	3.00	14	1.33	1.40	8 - 14			1/2"-14NPT	
3	VGD3.0NPT11.5RH/LH		11.5	1.64	1.60	9 - 15			1"-11.5NPT	
3	VGD3.0NPT11.5RH-RS/LS		11.5	1.64	1.60	9 - 15	1.5°	○	1"-11.5NPT	

● In stock ○ Available upon request | LH Helix threads available upon request

ТОВ «СМАРТТЕК ІНЖИНІРИНГ», т. +380-50-396-90-96, info@smarttec.com.ua, https://www.smarttec.com.ua

VG-Cut Tools

External Monoblock Tools with HPC	31
External Monoblock Tools	32
Reinforced Monoblock Tools with HPC	33
Reinforced Monoblock Tools	34
Blades with HPC	35
Blades	35
Reinforced Blades (Screw Clamping) with HPC	36
Reinforced Blades (Screw Clamping)	37
Reinforced Blades	38
Blade Holders	38
Radial Modules	39
Modular Bodies	40
Radial Modules with HPC	41
Face Grooving Modules with HPC	42
Modular Bodies with HPC	43
Modular V-CAP Holders with HPC	44

VG-Cut Tools - Ordering Code System

Monoblock Toolholders

VG	E	R	2525	3	T12	PH	C
1	2	9	3	4	5	10	11

Blades

VG	P	32	4	D	C
1	2	7	4	8	11

Modules

VG	A	R	20	T25	4	S	C
1	2	9	7	5	4	8	11

Face Grooving Modules

VG	F	R	4860	T24	4	C
1	2	9	12	5	4	11

Blade Holders / Modular Bodies

VB	A	R	2525	32	C
1	6	9	3	7	11

V-CAP Bodies



VB	C	R	C5	-	90	-	C
1	2	9	3		7		11

1 – Tools/Holders VG - Holders, Blades, Modules VB - Blade Holders, Modular Bodies	2 – Type A - Radial module C - V-CAP body E - External tool F - Face module M - Square body P - Universal blade W - Reinforced blade WS - Reinforced blade with screw clamping	3 – For External Holders Shank Size	4 – Pocket Size 1.5, 2, 3, 4, 5, 6
		3 – For V-CAP Holders Polygon Size (C4, C5, C6)	
5 – Depth of Cut T12 - Limit Depth of Cut 12 mm	6 – Holders A - Universal	7 – Blade Height 20, 25, 26, 32 00, 45, 90 Approach angle	8 – Number of Pockets D - Double S - Single
9 – RH or LH R - RH L - LH None - Neutral	10 – PH PH - Reinforced blade structure	11 – Coolant C - Coolant	12 – Dmin - Dmax Dmin - Dmax (For Face Grooving)

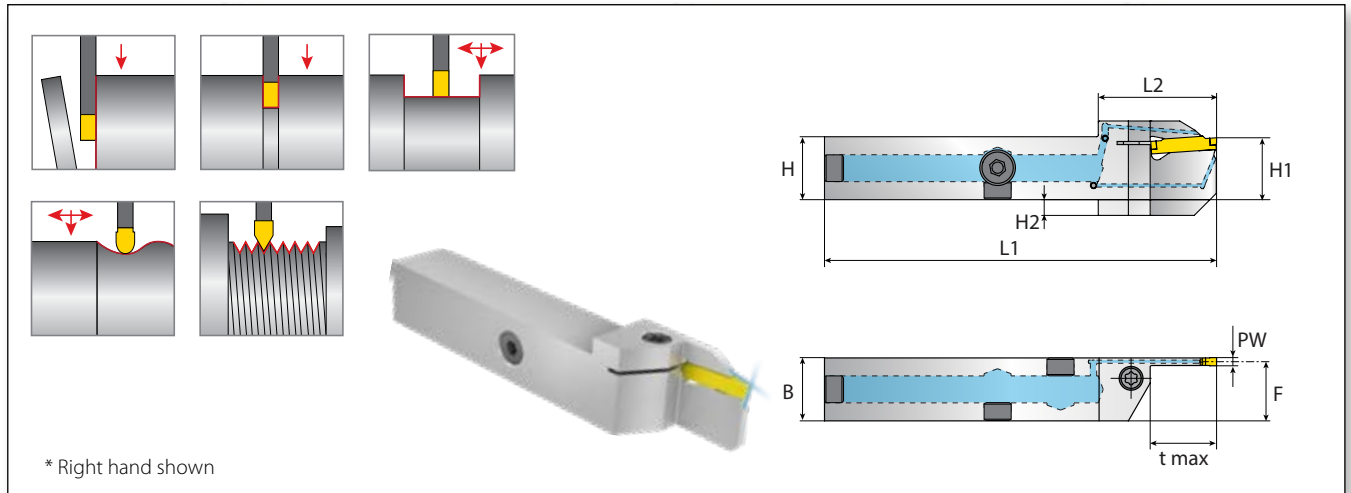

External Monoblock Tools with High Pressure Coolant Thru Grooving, Parting Off, Turning & Threading



Ordering Code		Dimensions mm						Spare Parts	
RH/LH	PW	t max	HXB	H1	F	L1	L2		
VGER/L2020-3T12C	3	12	20x20	20	18.8	124.6	28.5	SM5x20-T25	K5T
VGER/L2020-3T21C		21	20x20	20	18.8	124.6	37.6		
VGER/L2525-3T12C	4	12	25x25	25	23.8	124.6	30.6		
VGER/L2525-3T21C		21	25x25	25	23.8	124.6	37.6		
VGER/L2525-4T21C		21	25x25	25	23.3	124.6	37.6		

* Recommended Tightening torque: PW3 - 4.5 Nm, PW4 - 5Nm

External Monoblock Tools

Grooving, Parting Off, Turning & Threading

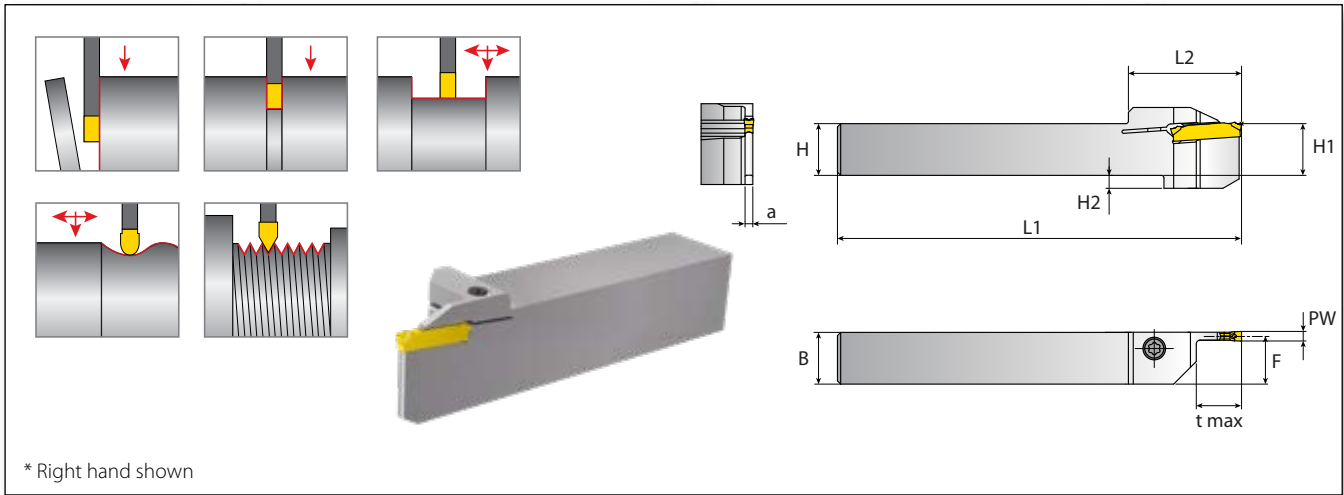

* Right hand shown

Ordering Code		Dimensions mm								Spare Parts		
RH/LH	PW	t max	HXB	H1	H2	F	L1	L2	a			
VGER/L1616-2NT12	2	12	16x16	16	4	15.1	125	35	1.8	SM4x16-T20	K4TF	-
VGER/L2020-2NT12		12	20x20	20	-	19.1	125	35	1.8			
VGER/L2525-2NT08		8	25x25	25	-	24.1	125	35	1.8			
VGER/L1212-3NT08	3	8	12x12	12	4	10.75	125	35	2.5	SM3.5X14-T15	-	KT-15
VGER/L1212-3NT12		12	12x12	12	4	10.75	125	35	2.5			
VGER/L1616-3NT12		12	16x16	16	4	14.75	125	35	2.5			
VGER/L1616-3NT21		21	16x16	16	4	14.75	125	35	2.5			
VGER/L2020-3NT08		8	20x20	20	-	18.75	125	35	2.5			
VGER/L2020-3NT12		12	20x20	20	-	18.75	125	35	2.5			
VGER/L2020-3NT21		21	20x20	20	-	18.75	125	35	2.5			
VGER/L2525-3NT08		8	25x25	25	-	23.75	125	35	2.5			
VGER/L2525-3NT12		12	25x25	25	-	23.75	125	35	2.5			
VGER/L2525-3NT21		21	25x25	25	-	23.75	125	35	2.5			
VGER/L1616-4NT21	4	21	16x16	16	4	14.3	125	35	3.4	SM4x16-T20	-	K6T
VGER/L2020-4NT12		12	20x20	20	-	18.3	125	35	3.4			
VGER/L2020-4NT21		21	20x20	20	-	18.3	125	35	3.4			
VGER/L2525-4NT08		8	25x25	25	-	23.3	125	35	3.4			
VGER/L2525-4NT12		12	25x25	25	-	23.3	125	35	3.4			
VGER/L2525-4NT21		21	25x25	25	-	23.3	125	35	3.4			
VGER/L3232-4NT21		21	32x32	32	-	30.3	125	35	3.4			
VGER/L2525-5T22**	5	22	25x25	25	-	23.0	150	43	4.0	SM5x20-T25	-	K5T
VGER/L3232-5T22**		22	32x32	32	-	30.0	170	43	4.0			
VGER/L2525-6T24**	6	24	25x25	25	-	22.5	150	45	5.0	SM6x20	-	K5H
VGER/L3232-6T24**		24	32x32	32	-	29.5	170	45	5.0			

* Tightening Torque: PW2 - 3Nm, PW3/4/5/6 - 5Nm

** Mounting and Replacing Inserts for 5mm & 6mm Monoblock Toolholders:

- 1** Unlock the top screw using the key provided.

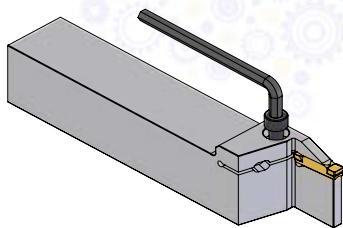

- 2** Place the same key in the "pocket." Turn and hold the key to loosen the pocket and remove the insert. Place the new insert in the pocket.

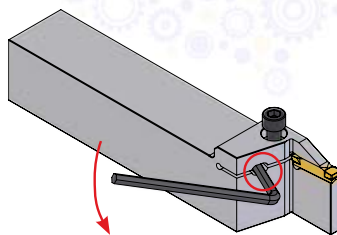

- 3** Now remove the key from the pocket and secure the insert by firmly locking the top screw.

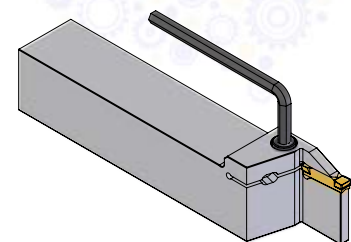

| Tools should not be clamped without an insert inside the pocket.

Reinforced Monoblock Tools with High Pressure Coolant Thru Grooving, Parting Off & Threading

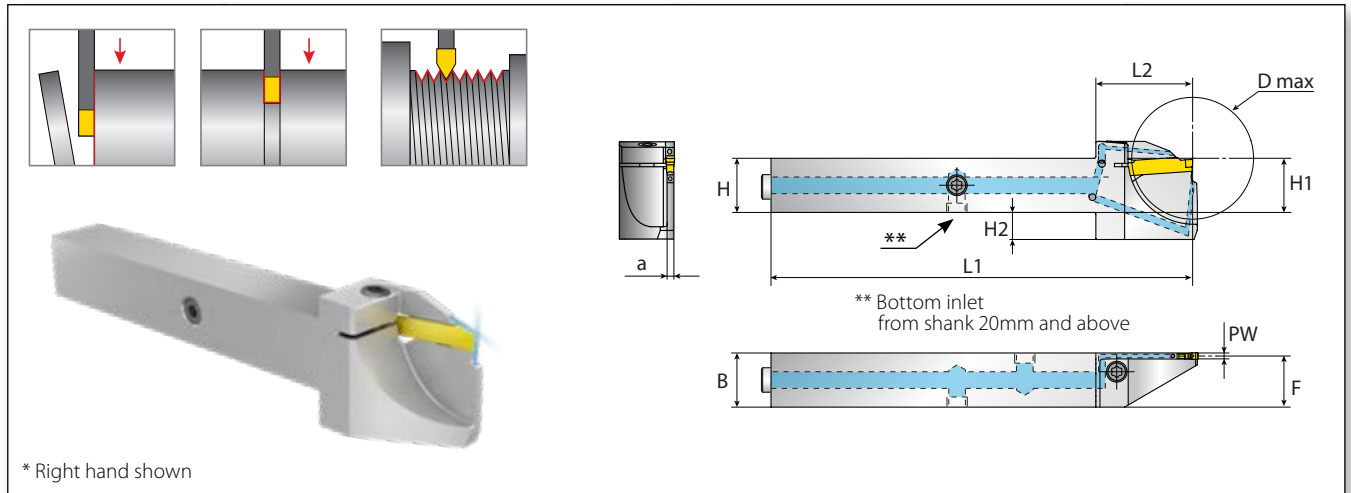

* Right hand shown

Spare Parts

Ordering Code		Dimensions mm														
RH/LH	PW	D max	HXB	H1	F	L1	L2	a	H2	Cylindrical Screw*	Key	Plug Screw x2				
VGER/L1010-1.5T10-PHC	1.5	20	10x10	10	9.35	110	24.6	1.3	7	SM4x14 T15	LT15	Plug M6x6				
VGER/L1212-1.5T10-PHC		20	12x12	12	11.35	125	22.6		5							
VGER/L1616-1.5T10-PHC		20	16x16	16	15.35	125	22.6		2							
VGER/L1010-2T10PHC	2	20	10x10	10	9.1	109.6	26	1.8	7			SM4x14 T15	LT15	Plug M6x6		
VGER/L1212-2T12PHC		24	12x12	12	11.1	124.6	24		6							
VGER/L1616-2T12PHC		24	16x16	16	15.1	124.6	24		2							
VGER/L1616-2T18PHC	3	36	16x16	16	15.1	124.6	30	2.4	8					SM4x14 T15	LT15	Plug G1/8"
VGER/L2020-2T18PHC		36	20x20	20	19.1	124.6	30		4							
VGER/L1212-3T12PHC		24	12x12	12	10.8	124.6	24		6							
VGER/L1616-3T12PHC	3	24	16x16	16	14.8	124.6	24	2.4	2			SM4x14 T15	LT15			Plug G1/8"
VGER/L2020-3T21PHC		42	20x20	20	18.8	124.6	32		7							
VGER/L2525-3T21PHC		42	25x25	25	23.8	124.6	32		2							

* Recommended Tightening Torque: 1.5, 2.0 mm width - 4 Nm max | 3.0 mm width - 5 Nm max.



Standard Key KT-15 is supplied with tool. A torque meter can be ordered separately for greater tightening accuracy.

The following VARGUS accessories for use with HPC can be ordered separately:

1. Tube Connector 25-6P (x1)
 2. Fittings (x2): Angled Fitting M6x6P or Straight Fitting M6x6P
- For more information see page 21.

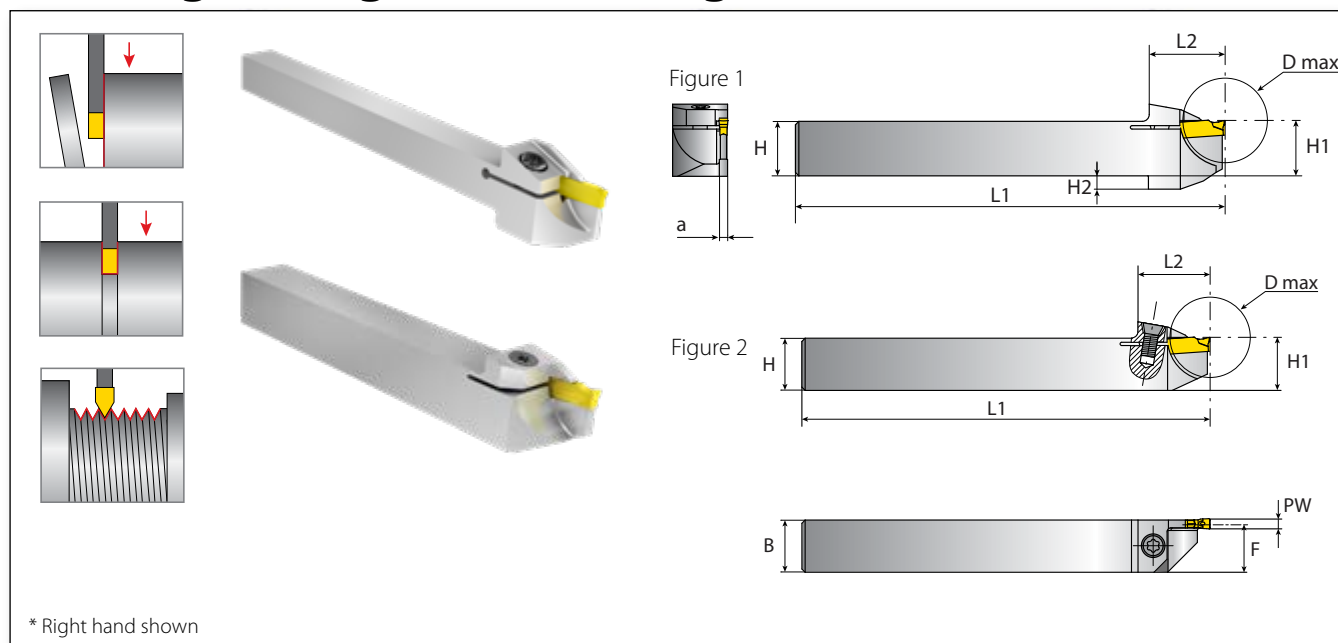
Reinforced Monoblock Tools Grooving, Parting Off & Threading



Ordering Code		Dimensions mm								Spare Parts		
RH/LH	PW	D max	HXB	H1	H2	F	L1	L2	a			
VGER/L1010-1.5T6.5-PH	1.5	13	10x10	10	4	9.35	125	22	1.3	Cylindrical Screw*	Key	
VGER/L1010-1.5T10-PH		20	10x10	10	4	9.35	125	22	1.3			
VGER/L1212-1.5T6.5-PH		13	12x12	12	4	11.35	125	22	1.3			
VGER/L1212-1.5T10-PH		20	12x12	12	4	11.35	125	22	1.3			
VGER/L1616-1.5T10-PH		20	16x16	16	-	15.35	125	22	1.3			
VGER/L1010-2T12PH	2	24	10x10	10	4	9.1	125	22	1.8			
VGER/L1212-2T08PH		16	12x12	12	4	11.1	125	22	1.8			
VGER/L1212-2T12PH		24	12x12	12	4	11.3	125	22	1.4			
VGER/L1616-2T12PH		24	16x16	16	-	15.3	125	22	1.4			
VGER/L1616-2T21PH		42	16x16	16	-	15.3	125	30	1.4			
VGER/L2020-2T12PH		24	20x20	20	-	19.3	125	22	1.4			
VGER/L2020-2T21PH		42	20x20	20	-	19.3	125	30	1.4			
VGER/L2525-2T21PH		42	25x25	25	-	24.3	125	30	1.4			
VGER/L1616-3T12PH		3	24	16x16	16	-	14.8	125	22			2.4
VGER/L1616-3T21PH			42	16x16	16	-	18.8	125	30			2.4
VGER/L2020-3T12PH	24		20x20	20	-	18.8	125	22	2.4			
VGER/L2020-3T21PH	42		20x20	20	-	18.8	125	30	2.4			
VGER/L2525-3T21PH	24		25x25	25	-	23.8	125	22	2.4			
VGER/L2525-3T21PH	42	25x25	25	-	23.8	125	30	2.4				

*Tightening Torque: 1.5, 2.0 mm width - **Cannot Exceed 3 Nm max** | 3.0 mm width - 5 Nm max.

Standard Key K3TF is supplied with tool. A torque meter can be ordered separately for greater tightening accuracy.

| Tools should not be clamped without an insert inside the pocket.

Blades with High Pressure Coolant Thru Grooving, Parting Off

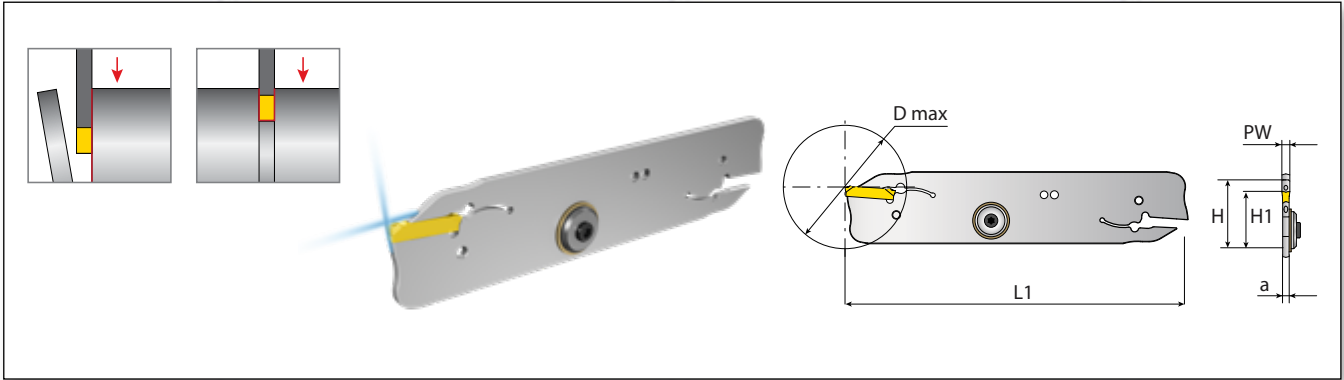

Ordering Code	Dimensions mm						Spare Parts		
	H	PW	D max*	H1	L1	a	Key**	Sealing Cap Key**	Sealing Cap
VGP26-3DC	26	3	70	21.4	110	2.5	VP-3	Key WS-15IP	WS-15IP
VGP32-3DC	32	3	100	24.8	150	2.5	VP-3	Key WS-15IP	WS-15IP
VGP32-4DC	32	4	100	24.8	150	3.4	VP-4	Key WS-15IP	WS-15IP

! Blades marked with **C** are offered with High Pressure Coolant.

* D max figures presented are for single sided insert (VGS).

** Not included. Please order separately.

Blades Grooving & Parting Off

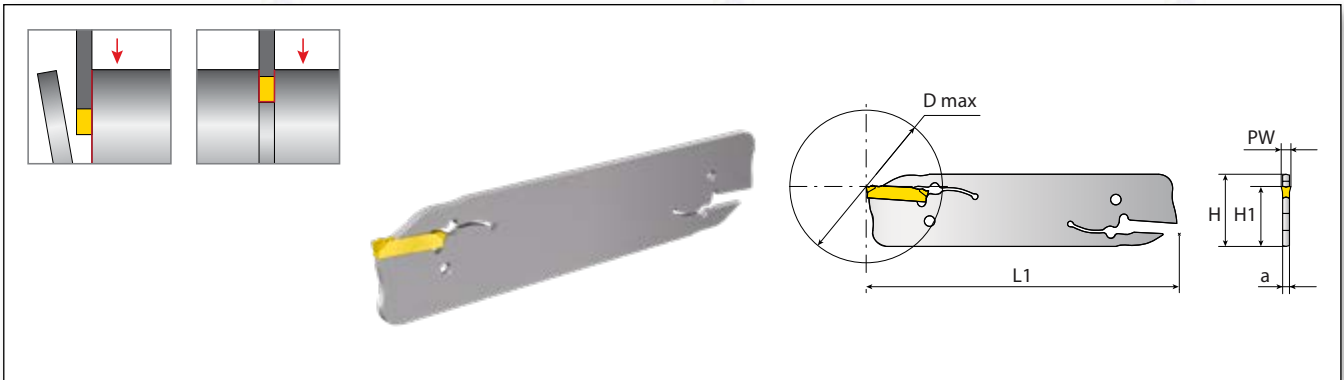



Ordering Code	Dimensions mm						Spare Parts	
	H	PW	D max*	H1	L1	a	Key**	
VGP26-2D	26	2	50	21.4	110	1.8	VP-3	
VGP32-2D	32	2	50	24.8	150	1.8		
VGP26-3D	26	3	70	21.4	110	2.5		
VGP32-3D	32	3	100	24.8	150	2.5		
VGP35-3S	35	3	100	33.5	150	2.5		
VGP32-4D	32	4	100	24.8	150	3.4	VP-4	
VGP32-5D	32	5	100	24.8	150	4.0	VP-G	
VGP32-6D	32	6	100	24.8	150	5.2		

* D max figures presented are for single sided insert (VGS).

** Not included. Please order separately.

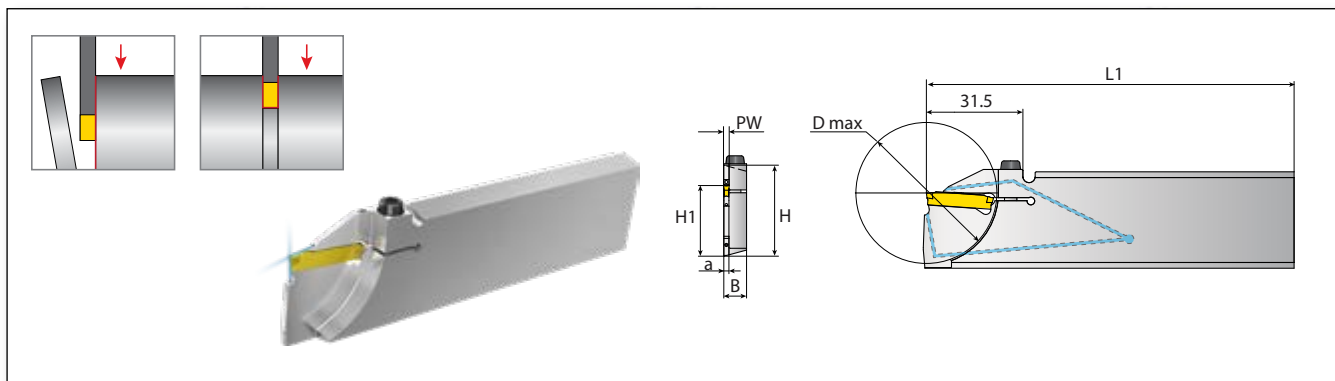
Reinforced Blades (Screw Clamping) with HPC Grooving, Parting Off



Ordering Code								Spare Parts	
Dimensions mm									
RH/LH	H	PW	D max*	H1	L1	B	a	Screw**	Key
VGWSR 26-2SRC	26	2	46	21.4	110	8	1.8	SM4.0x16-T20	K6T
VGWSR 26-2SLC	26	2	46	21.4	110	8	1.8		
VGWSL 26-2SLC	26	2	46	21.4	110	8	1.8		
VGWSL 26-2SRC	26	2	46	21.4	110	8	1.8		
VGWSR 32-2SRC	32	2	46	24.8	120	8	1.8		
VGWSR 32-2SLC	32	2	46	24.8	120	8	1.8		
VGWSL 32-2SLC	32	2	46	24.8	120	8	1.8		
VGWSL 32-2SRC	32	2	46	24.8	120	8	1.8		
VGWSR 26-3SRC	26	3	46	21.4	110	8	2.4		
VGWSR 26-3SLC	26	3	46	21.4	110	8	2.4		
VGWSL 26-3SLC	26	3	46	21.4	110	8	2.4		
VGWSL 26-3SRC	26	3	46	21.4	110	8	2.4		
VGWSR 32-3SRC	32	3	46	24.8	120	8	2.4		
VGWSR 32-3SLC	32	3	46	24.8	120	8	2.4		
VGWSL 32-3SLC	32	3	46	24.8	120	8	2.4		
VGWSL 32-3SRC	32	3	46	24.8	120	8	2.4		

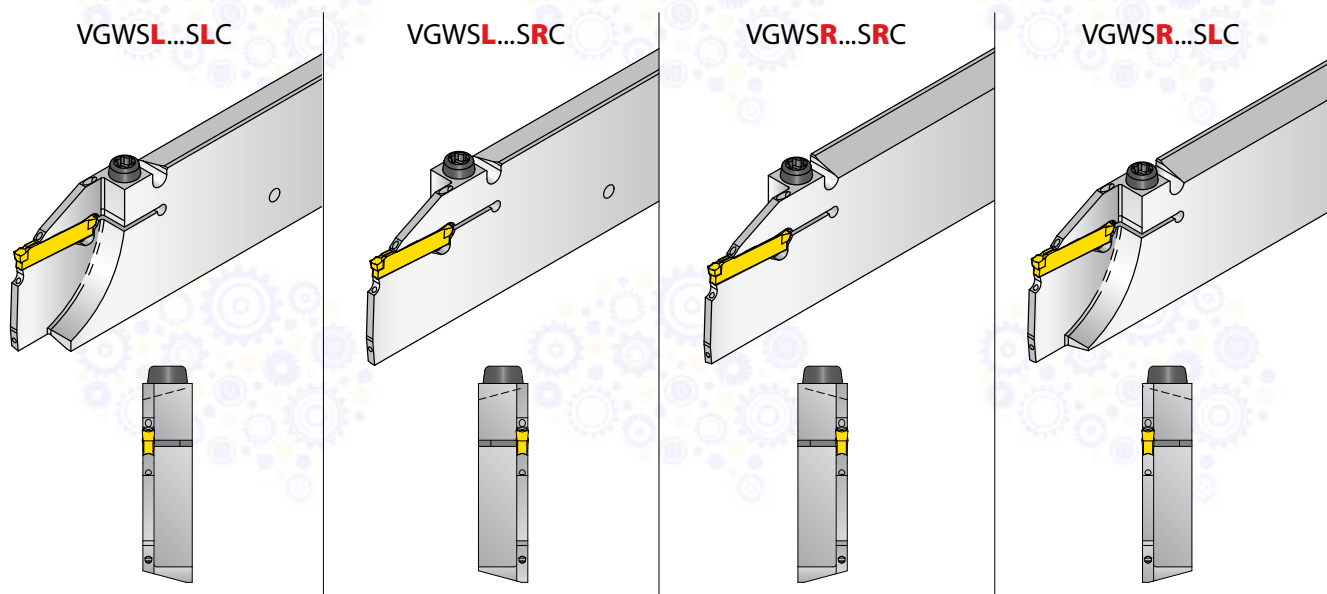

* D max figures presented are for single sided insert (VGS).

** Recommended tightening torque: PW2 - 3Nm, PW3 - 4.5Nm.

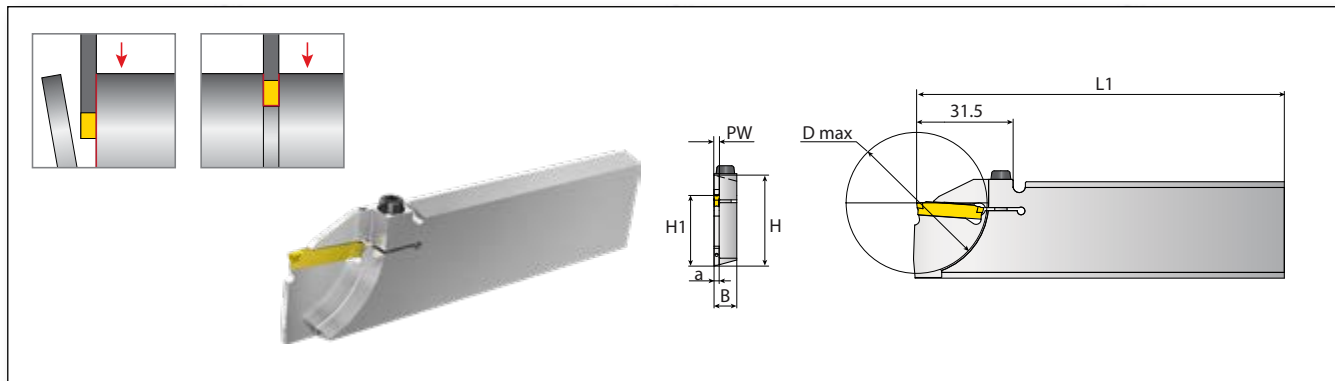

Reinforced Blades (Screw Clamping) Grooving, Parting Off



Ordering Code								Dimensions mm		Spare Parts	
RH/LH	H	PW	D max*	H1	L1	B	a				
								Screw**	Key		
VGWSR 26-2SR	26	2	46	21.4	110	8	1.8	SM4.0x16-T20	K6T		
VGWSR 26-2SL	26	2	46	21.4	110	8	1.8				
VGWSL 26-2SL	26	2	46	21.4	110	8	1.8				
VGWSL 26-2SR	26	2	46	21.4	110	8	1.8				
VGWSR 32-2SR	32	2	46	24.8	120	8	1.8				
VGWSR 32-2SL	32	2	46	24.8	120	8	1.8				
VGWSL 32-2SL	32	2	46	24.8	120	8	1.8				
VGWSL 32-2SR	32	2	46	24.8	120	8	1.8				
VGWSR 26-3SR	26	3	46	21.4	110	8	2.4				
VGWSR 26-3SL	26	3	46	21.4	110	8	2.4				
VGWSL 26-3SL	26	3	46	21.4	110	8	2.4				
VGWSL 26-3SR	26	3	46	21.4	110	8	2.4				
VGWSR 32-3SR	32	3	46	24.8	120	8	2.4				
VGWSR 32-3SL	32	3	46	24.8	120	8	2.4				
VGWSL 32-3SL	32	3	46	24.8	120	8	2.4				
VGWSL 32-3SR	32	3	46	24.8	120	8	2.4				

* D max figures presented are for single sided insert (VGS).

** Recommended tightening torque: PW2 - 3Nm, PW3 - 4.5Nm.

Reinforced Blades Grooving, Parting Off

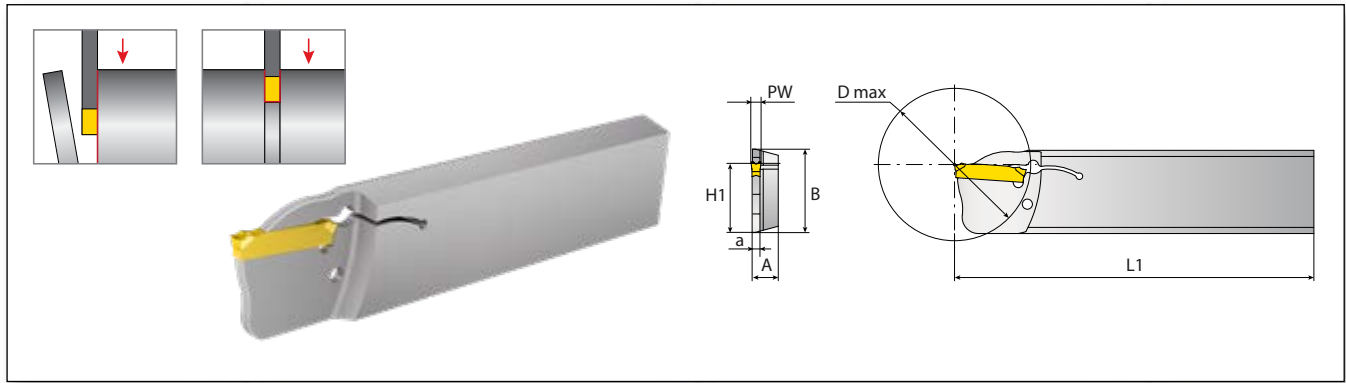

Ordering Code								Dimensions mm		Spare Parts
RH/LH	B	PW	D max*	H1	L1	A	a	Key**		
VGWR/L26-2S	26	2	65	21.4	110	8.0	1.8	VP-3		
VGWR/L32-2S	32	2	65	24.7	110	8.0	1.8			
VGWR/L26-3S	26	3	65	21.4	110	8.0	2.5			
VGWR/L32-3S	32	3	65	24.7	110	8.0	2.5			

* D max figures presented are for single sided insert (VGS).
 ** Not included. Please order separately.

Blade Holders

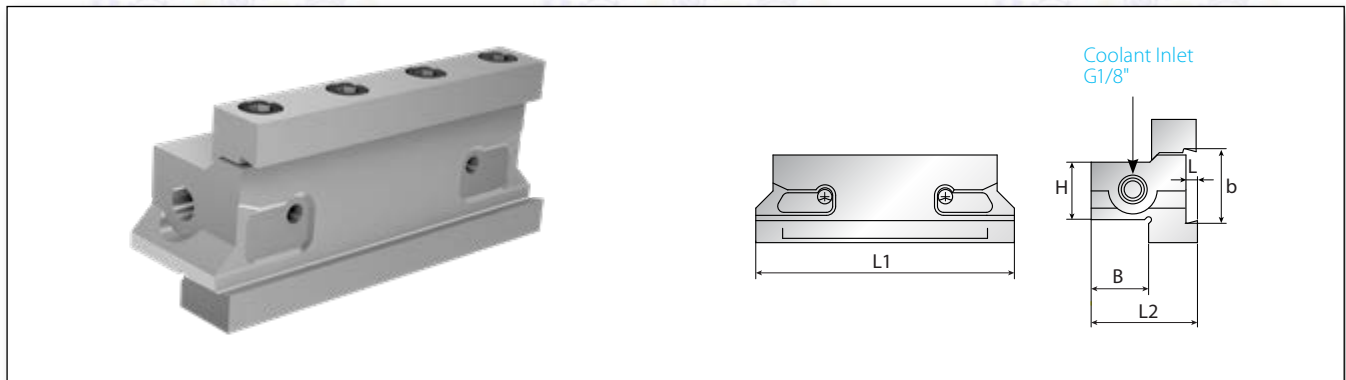

Ordering Code							Dimensions mm		Spare Parts	
b	H	B	L	L1	L2	Clamping Screw*(x4)		Key		
VBA 2020-26	26	20	20	4	90	M6x1.0x25		K5H		
VBA 2520-32	32	25	20	5.2	110					

* Tightening Torque: 10 Nm max

Necessary Parts When Using Blades with High Pressure Coolant Thru:

1. Plug G1/8"P (x1)
2. Plug DIN 916 GALV M6x8P (x1)
3. Tube Connector 25-6P (x1)
4. Fittings (x2): Straight Fitting G1_8x6P or Angled Fitting G1_8x6P

The above items are not included and should be ordered separately.
 For more information please see page 21.

Modules for Grooving, Parting Off & Turning

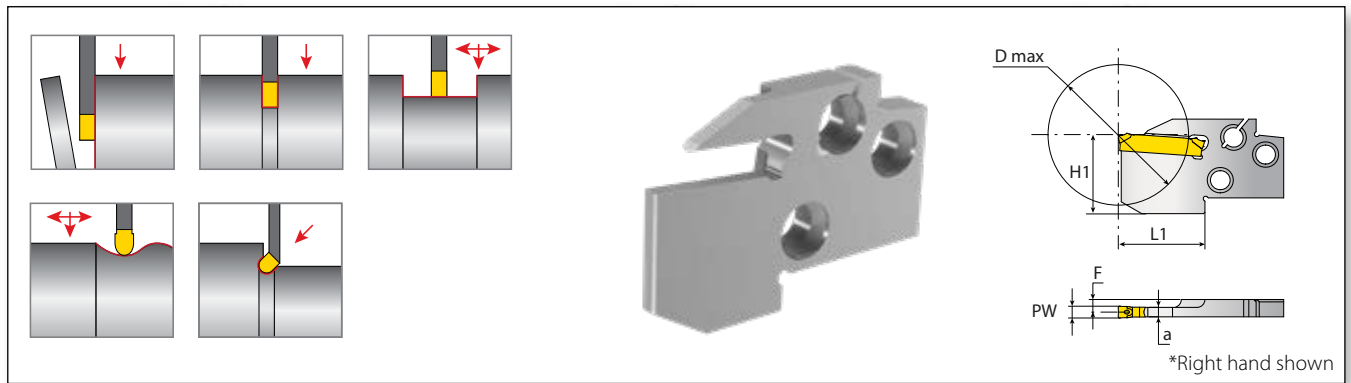

Ordering Code		Dimensions mm					
RH/LH	PW	D max	H1	F	L1	a	
VGAR/L20T25-2S	2	40	20	3.7	22	1.4	
VGAR/L20T25-3S	3	40	20	3.2	24	2.4	
VGAR/L20T25-4S	4	44	20	2.9	24	3.0	
VGAR/L25T25-2S	2	40	25	5.2	22	1.4	
VGAR/L25T25-3S	3	40	25	4.7	24	2.4	
VGAR/L25T25-4S	4	44	25	4.4	24	3.0	

Radial (0°-90°) Module Limitations

Dimensions mm	
D max	t max
50	20.0
100	17.0
150	16.0
200	15.2

45° (Undercut) Module Limitations

Dimensions mm			
Pocket Width PW	Square Groove as max	Round Groove ar max	D min
2	0.91	0.5	48
3	1.12		
4	1.32		

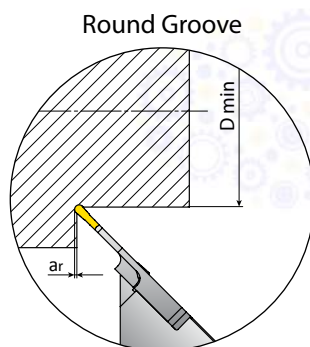
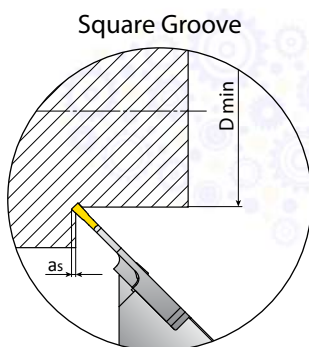

Mounting and Replacing Modules:

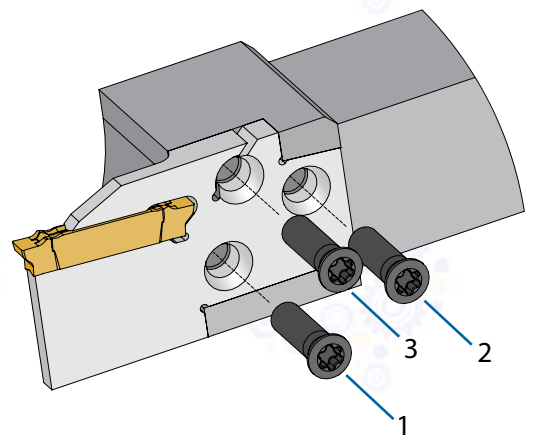

1. Clamp the module using screws 1, 2 and 3.
2. Clamp module to body with screw no. 1, followed by screw no. 2.
3. Finally, clamp the insert to the holder using screw no. 3.

Modular Bodies for Grooving, Parting Off & Turning

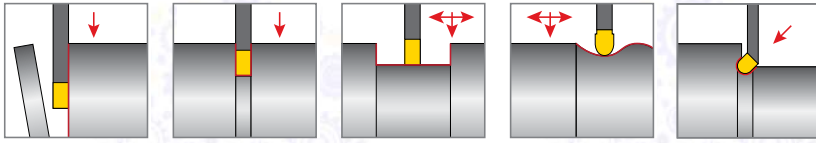

Parallel Square Bodies

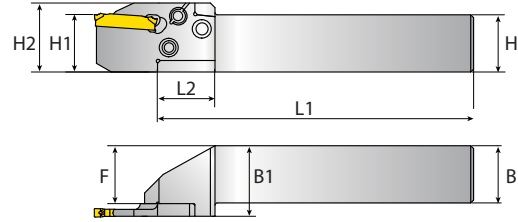

* Right hand shown

Spare Parts

Ordering Code		Dimensions mm						Spare Parts	
RH/LH	H/H1	B	B1	H2	F	L1	L2	Conical Screw*	Key
VBMR/L2020-00	20	20.0	24.3	24	20.15	110	20	SM4x14 T15	KT-15
VBMR/L2525-00	25	25.0	31.0	30	25.50	140	25	SM5x18 T20	K6T

90° Square Bodies

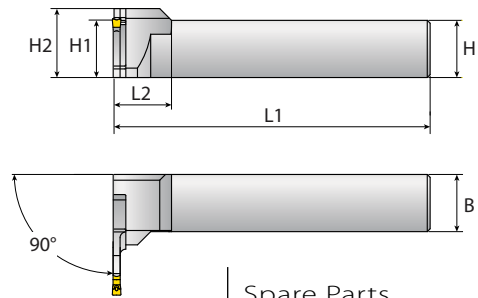

* Right hand shown

Spare Parts

Ordering Code		Dimensions mm					Spare Parts	
RH/LH	H/H1	B	H2	L1	L2	Conical Screw*	Key	
VBMR/L2020-90	20	20.0	24	110	20	SM4x14 T15	KT-15	
VBMR/L2525-90	25	25.0	30	140	28	SM5x18 T20	K6T	

! For 90° Right-hand Tool: Use right-hand body with left-hand module.

45° Square Bodies

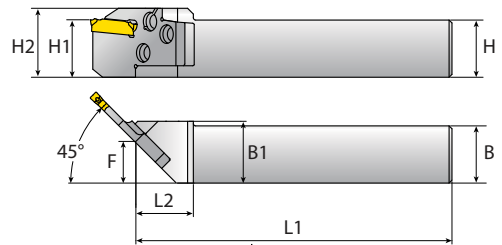

* Left hand shown

Spare Parts

Ordering Code		Dimensions mm						Spare Parts	
RH/LH	H/H1	B	B1	H2	L1	L2	F	Conical Screw*	Key
VBMR/L2020-45	20	20.0	21.5	24	110	20	14.5	SM4x10.5 T15 SM4x14 T15	KT-15
VBMR/L2525-45	25	25.0	26.0	30	140	25	18	SM5x13.5 T20 SM5x18 T20	K6T

! For 45° Right-hand Tool: Use right-hand body with left-hand module.

* Tightening Torque: T15 screws - 5 Nm max, T20 screws - 7 Nm max.

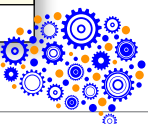

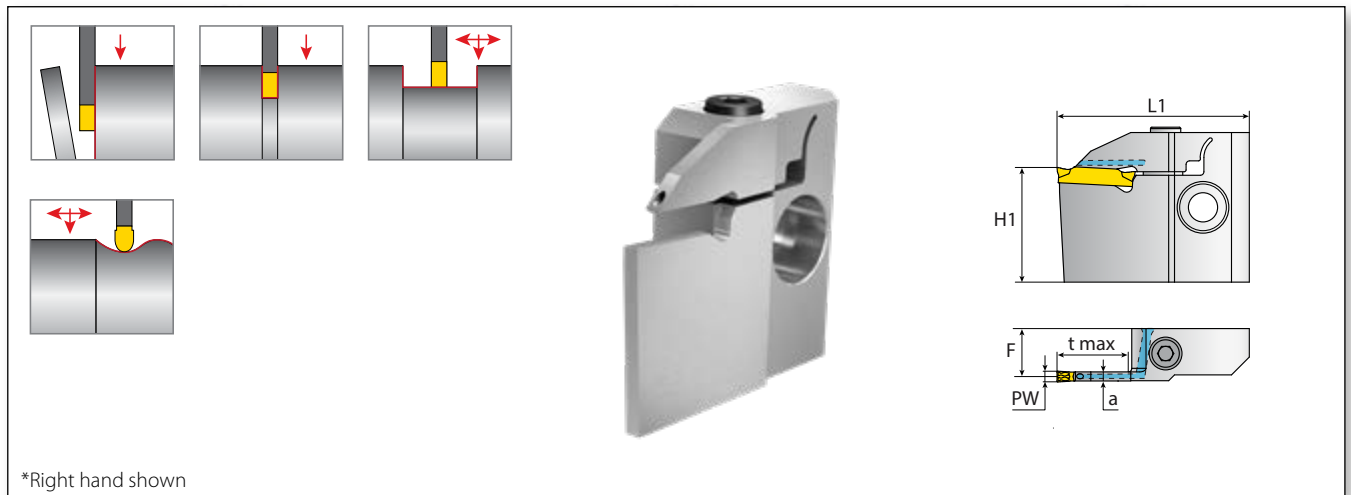

Radial Grooving Modules with High Pressure Coolant Thru



*Right hand shown

Spare Parts

Ordering Code		Dimensions mm						
RH/LH	PW	t max	H1	F	L1	a	Screw*	Key
VGAR/L-T09-2C	2	9	32	13.9	43	1.58	SM5x16	K4H
VGAR/L-T18-2C	2	18	32	13.9	52	1.58		
VGAR/L-T10-3C	3	10	32	13.3	44	2.48		
VGAR/L-T20-3C	3	20	32	13.3	54	2.48		
VGAR/L-T12-4C	4	12	32	13.0	46	3.10		
VGAR/L-T24-4C	4	24**	32	13.0	58	3.10		
VGAR/L-T15-5C	5	15	32	13.5	49	4.00		
VGAR/L-T30-5C	5	30**	32	12.5	64	4.00		
VGAR/L-T20-6C	6	20	32	13.0	54	5.00		
VGAR/L-T40-6C	6	40**	32	13.0	74	5.00		

* Tightening Torque: PW 2 mm - 4 Nm max; PW 3, 4, 5, 6 mm - 7 Nm max.

** T max figures presented for single sided inserts (VGS).

Mounting and Replacing Inserts for Radial and Face Grooving Modules with High Pressure Coolant Thru:

- 1 Unlock the top screw using the key provided.

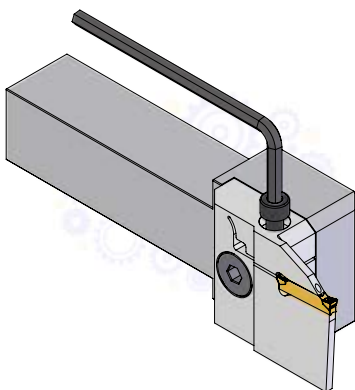

- 2 Place the same key in the "pocket." Turn and hold the key to loosen the pocket and remove the insert. Place the new insert in the pocket.

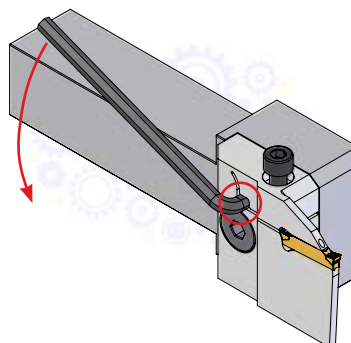

- 3 Now remove the key from the pocket and secure the insert by firmly locking the top screw.

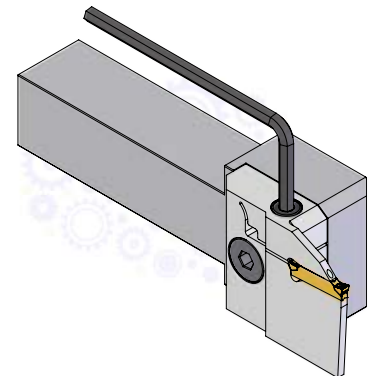

Tools should not be clamped without an insert inside the pocket.

Face Grooving Modules with High Pressure Coolant Thru

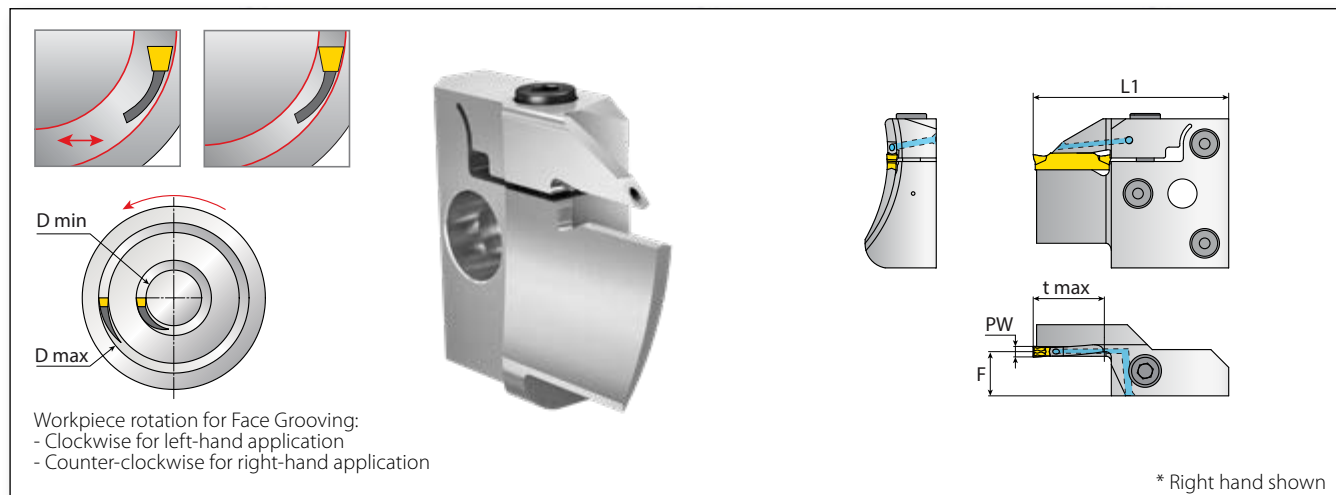

Ordering Code							Dimensions mm		Spare Parts	
RH/LH	PW	t max	D min	D max	F	L1	Screw*	Key		
VGFR/L-2530-T10-3C	3	10	23.50	32.00	12.5	45	SM5x16	K4H		
VGFR/L-3038-T10-3C			28.60	40.40						
VGFR/L-3848-T10-3C			36.60	50.40						
VGFR/L-4860-T10-3C			46.60	62.80						
VGFR/L-6075-T10-3C		58.70	78.20							
VGFR/L-75100-T10-3C		73.70	103.20							
VGFR/L-100200-T10-3C		99.20	204.60							
VGFR/L-6075-T20-3C		20	58.30	77.50						
VGFR/L-75100-T20-3C	73.70		103.20							
VGFR/L-100200-T20-3C		99.20	204.60							
VGFR/L-3048-T12-4C	4	12	27.60	49.00	12	59				
VGFR/L-4860-T12-4C			44.50	60.50						
VGFR/L-6075-T12-4C			55.60	75.10						
VGFR/L-75100-T12-4C			69.60	99.60						
VGFR/L-100150-T12-4C		92.30	147.70							
VGFR/L-150->-T12-4C		134.50	285.50							
VGFR/L-3048-T24-4C		24	27.60	49.00						
VGR/LF-4860-T24-4C			44.50	60.50						
VGFR/L-6075-T24-4C	55.60		75.10							
VGFR/L-75100-T24-4C	69.60		99.60							
VGFR/L-100150-T24-4C		92.30	147.70							
VGFR/L-150->-T24-4C		134.50	275.50							
VGFR/L-4255-T22-5C	5	22	38.40	61.00	13.5	60				
VGFR/L-5575-T22-5C			51.10	81.90						
VGFR/L-75130-T22-5C			70.30	143.90						
VGFR/L-130200-T22-5C			123.10	222.30						
VGFR/L-200->-T22-5C		189.00	788.40							
VGFR/L-130200-T45-5C		45	123.10	222.30						
VGFR/L-200400-T45-5C			189.00	475.90						
VGFR/L-450->-T45-5C			400.70	911.80						
VGFR/L-4255-T22-6C	6		22	36.50	63.30	13	92			
VGFR/L-5575-T22-6C		49.00		83.50						
VGFR/L-75130-T22-6C		68.20		145.00						
VGFR/L-130200-T22-6C		121.10		223.90						
VGFR/L-200->-T22-6C		188.40	813.10							
VGFR/L-130200-T45-6C		45	121.10	223.90						
VGFR/L-200400-T45-6C			189.10	492.00						
VGFR-450->-T45-6C			408.90	973.60						

* Tightening Torque 7 Nm max.

Tools should not be clamped without an insert inside the pocket.



Modular Bodies with High Pressure Coolant for Grooving, Face Grooving, Parting Off and Turning

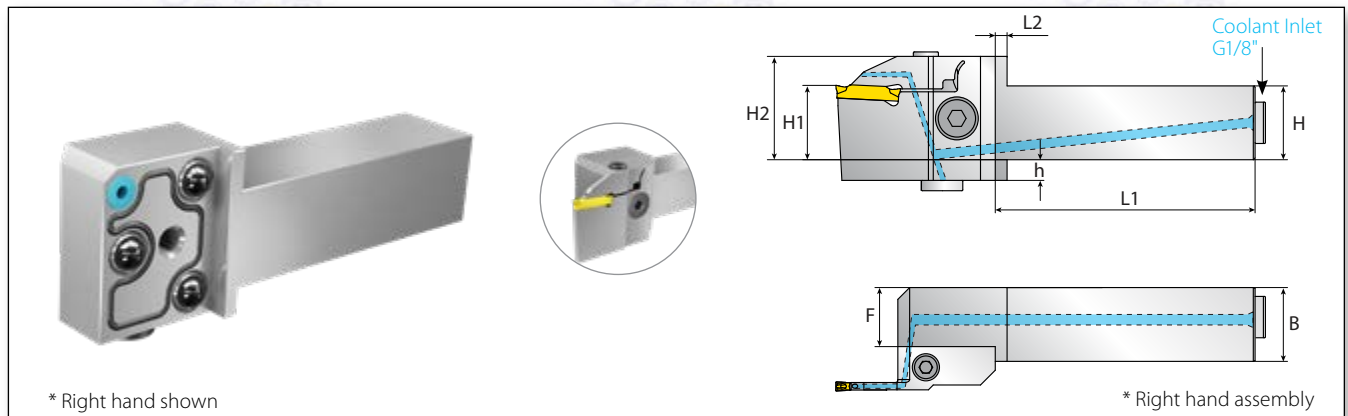
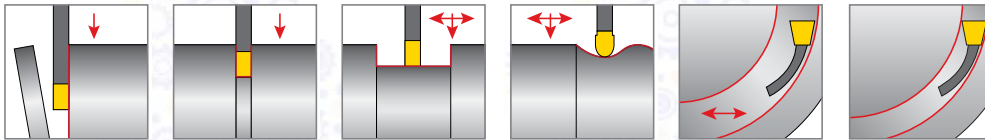

Parallel Square Bodies with HPC

Spare Parts

Ordering Code	Dimensions mm							Clamping Screw*	Key	Plug Screw	Coolant Seal	Anti Vibration O-Ring
	H/H1	B	H2	h	F	L1	L2					
VBMR/L2020-00-C	20	20	30	12	15	73	4	SM8x25	K6H	Plug G1/8"	Coolant Sleeve	O-RING Body Seal
VBMR/L2525-00-C	25	25	35	7	20	88	4					
VBMR/L3225-00-C	32	25	42	0	20	103	4					

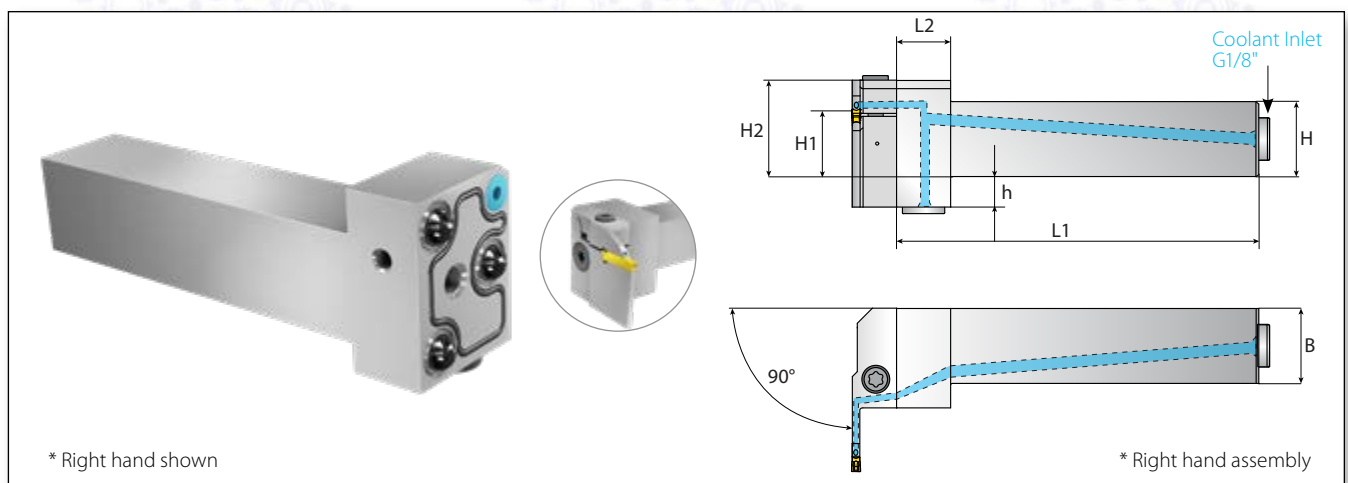

90° Square Bodies with HPC

Spare Parts

Ordering Code	Dimensions mm							Clamping Screw*	Key	Plug Screw	Coolant Seal	Anti Vibration O-Ring
	RH/LH	H/H1	B	H2	h	L1	L2					
VBMR/L2020-90-C	20	20	30	12	111	18	SM8x25	K6H	Plug G1/8"	Coolant Sleeve	O-RING Body Seal	
VBMR/L2525-90-C	25	25	35	7	120	18						
VBMR/L3232-90-C	32	32	42	0	130	18						

* Tightening Torque: 26 NM max.

Necessary Parts When Using Modules with High Pressure Coolant Thru:

1. Tube Connector 25-6P (x1)
2. Fittings (x2): Straight Fitting G1_8x6P or Angled Fitting G1_8x6P

The above items are not included and should be ordered separately. For more information see page 21.

ТОВ «СМАРТТЕК ІНЖИНІРИНГ», Т. +380-50-396-90-96, info@smarttec.com.ua, https://www.smarttec.com.ua

Modular V-CAP Holders with HPC

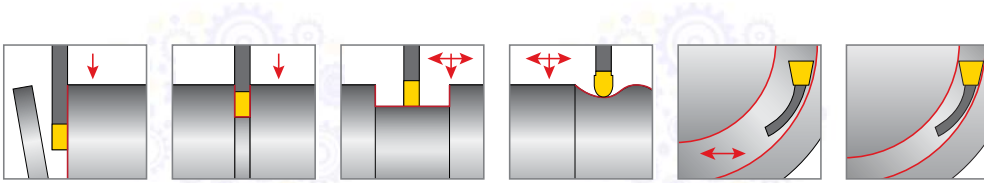

* RH+LH holder with Modular Cover. RH shown.

Parallel V-CAP Bodies with HPC

Spare Parts

Ordering Code		Dimensions mm					Spare Parts				
RH+LH	D	L	L1	L2	F	H1					
VBC C4-00-C	40	78	54	21	17		Clamping Screw* (x2)	Key	Modular Cover	Coolant Seal	Anti Vibration O-Ring
VBC C5-00-C	50	88	58	21	18.5	32	SM8x18	K6H	VG-MC	Coolant Sleeve	O-RING Body Seal
VBC C6-00-C	63	98	60	23	24.5						

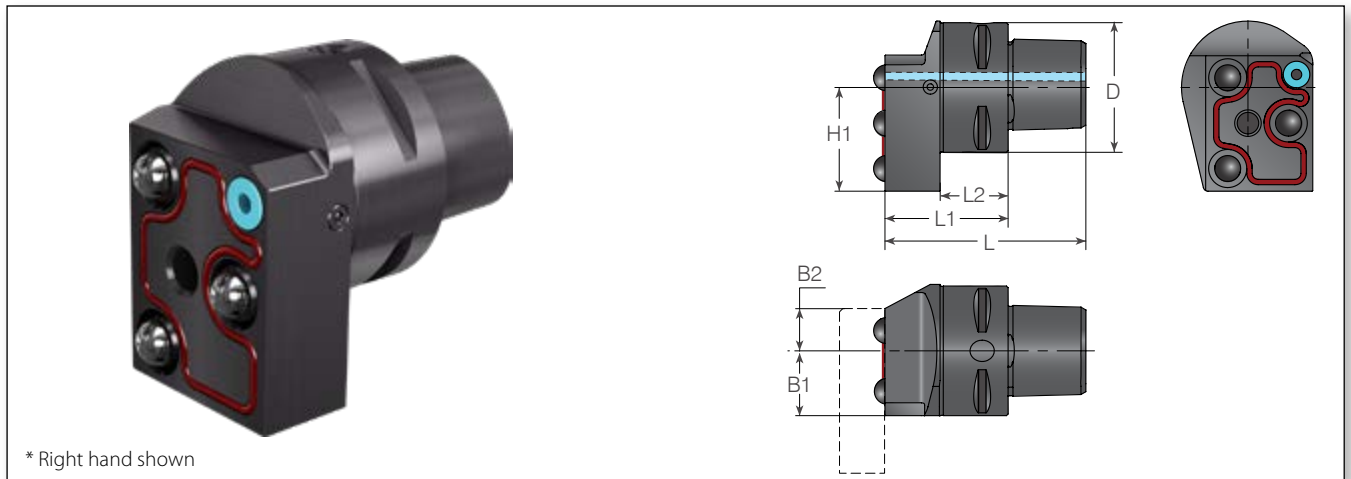

* Right hand shown

90° V-CAP Bodies with HPC

Spare Parts

Ordering Code		Dimensions mm							Spare Parts			
RH/LH	D	L	L1	L2	B1	B2	H1					
VBCR/L C4-90-C	40	64	40	21	20	13.0		Clamping Screw*	Key	Coolant Seal	Anti Vibration O-Ring	
VBCR/L C5-90-C	50	70	40	21	26.5	6.75	32	SM8x18	K6H	Coolant Sleeve	O-RING Body Seal	
VBCR/L C6-90-C	63	78	40	23	32.7	0.5						

V-CAP holders are according to ISO 26623.

* Tightening Torque: 26 Nm max.



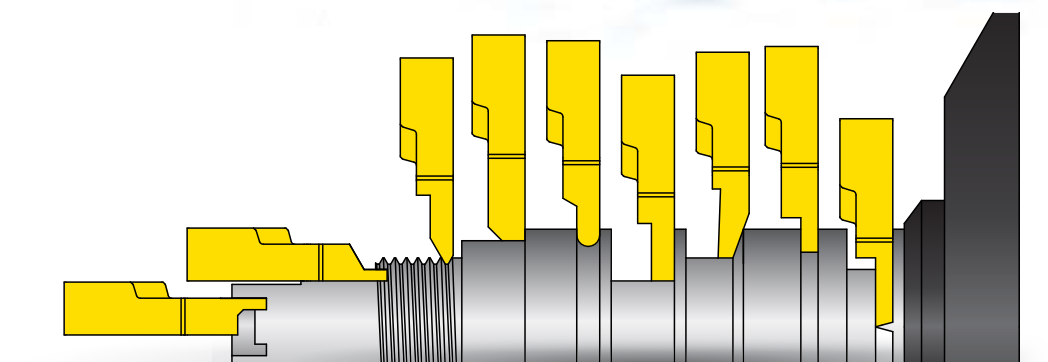
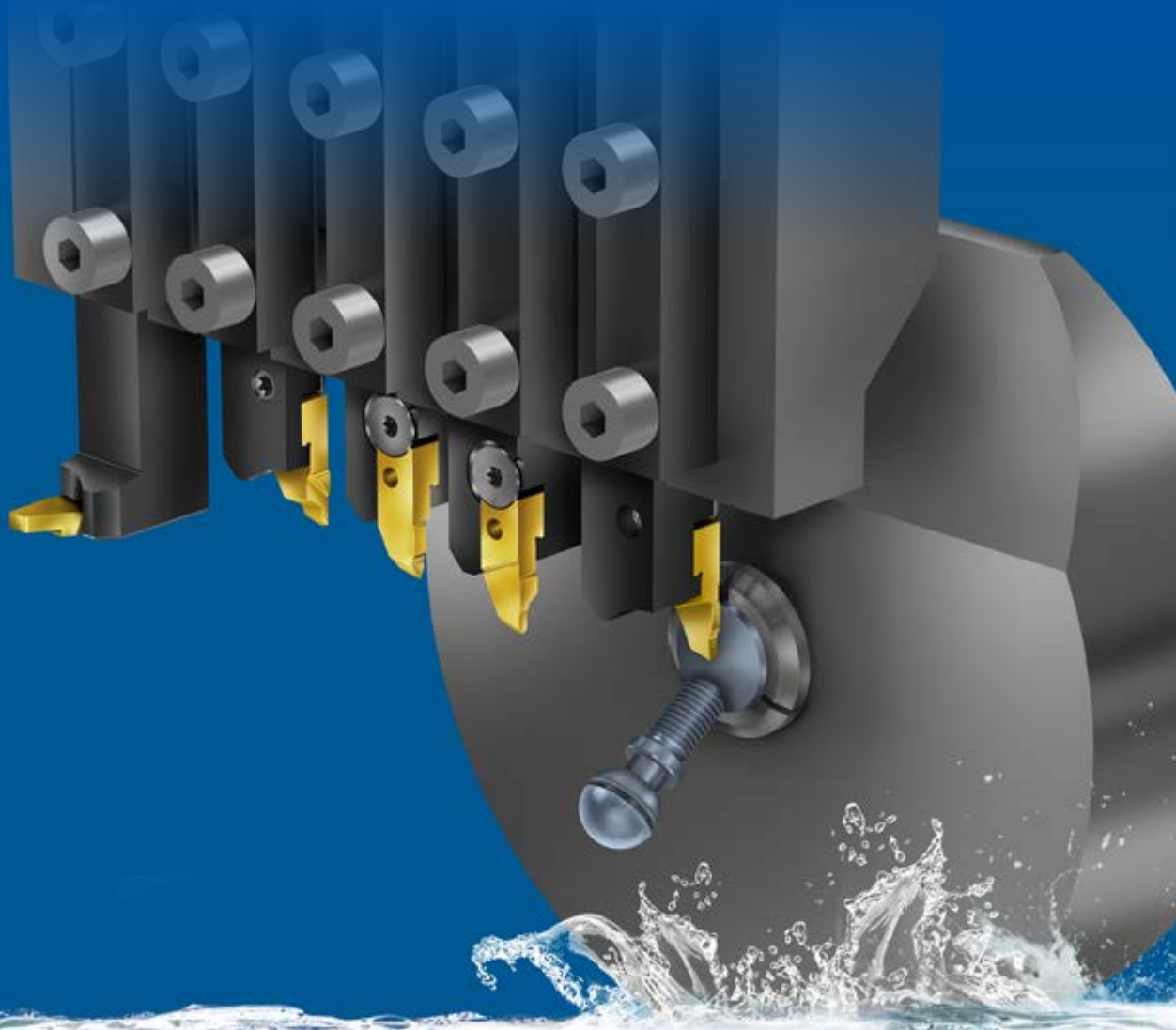

EXTERNAL GROOVE TURNING | **FINISHING**

ST-Cut

Precise Tools for Small Parts Machining

ST-Cut

Precise Tools for Small Parts Machining

Vargus is pleased to introduce the New ST-Cut, an innovative solution for machining small parts on Swiss type machines.

Features and Benefits:

- Unique insert replacement system
- Quick and easy change of insert inside the machine from both sides of the tool
- High repeatability of the cutting edge on all axes
- 17.0mm maximum parting off diameter, with up to 3.0mm notch width
- Excellent rigidity
- Insert edge treatment for increased tool life

ST-Cut Applications

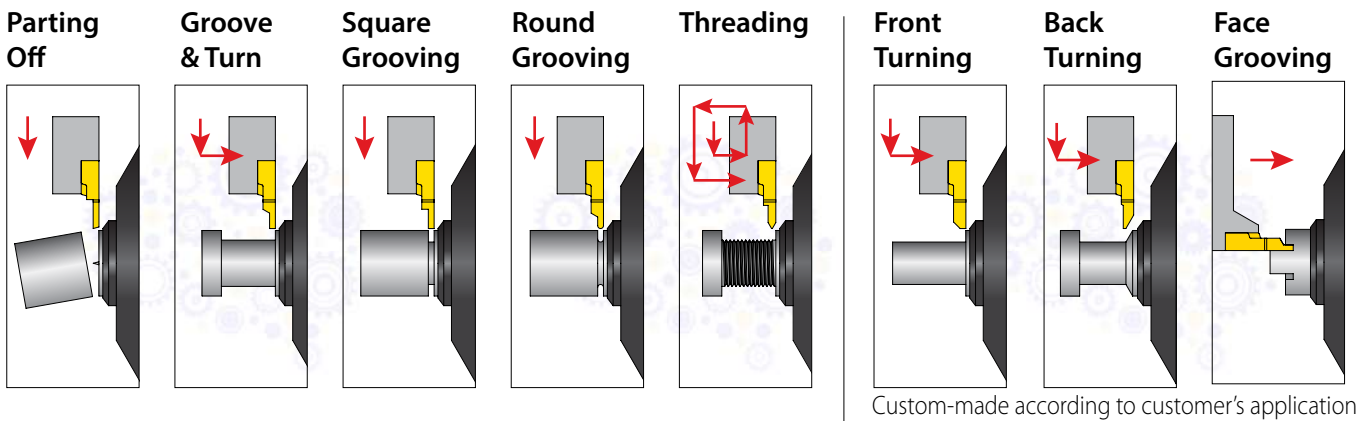

ST-Cut Unique Clamping System

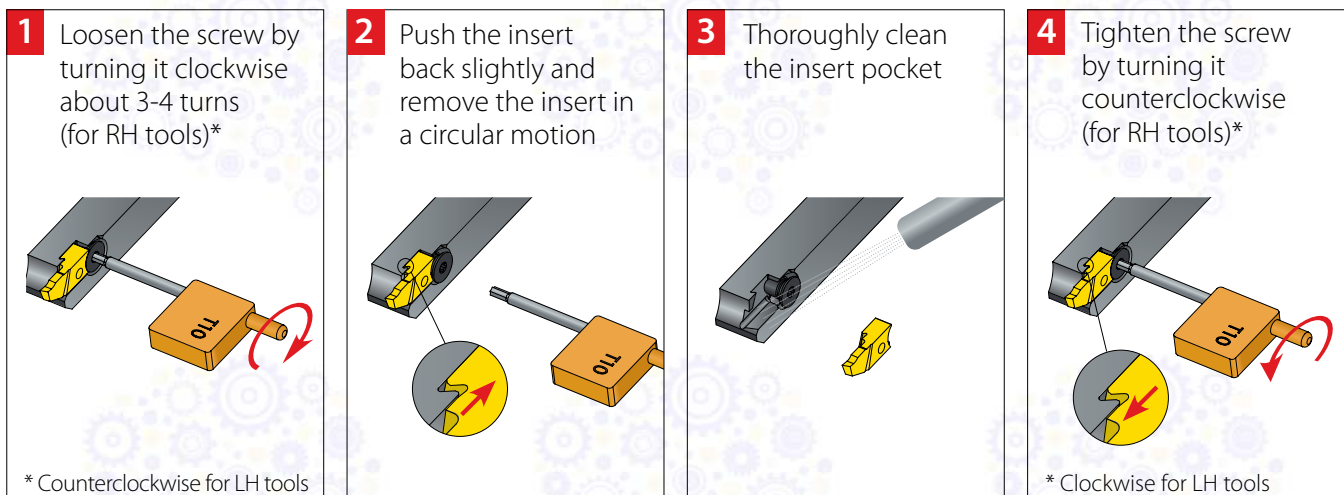

Double-sided screws for maximum accessibility on the machine

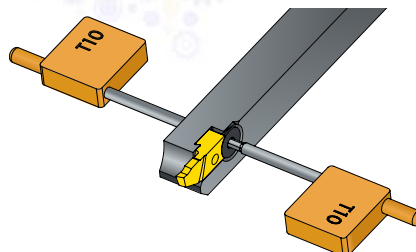

ST-Cut Technical Data

Geo-Rake Angle

The maximum diameter for parting off is 17.0mm, and up to 3.0mm notch width. The insert corner can pass the center of rotation up to 0.2mm maximum.

Rake Angle

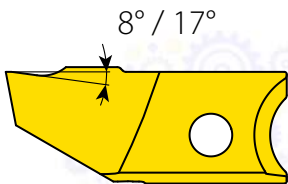

Positive Rake Angle Chip Former

Recommended for specific applications, depending on the type of application and workpiece material. Relatively sharp edge, designed for less build-up on the insert cutting edge. Highly recommended for Gummy materials such as Stainless Steel and Titanium.

Vargus also offers custom-made rake angles for defined applications.

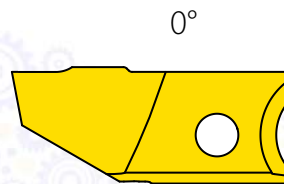

0° Rake Angle Chip Former

Insert geometry designed for general use applications. Relatively dull edge, which creates fewer fractures. Recommended for High Alloy Steels and hard abrasive materials.

Grades

ST-Cut inserts are offered in two different grades: **VPG** and **VS020**.

VPG is PVD coated, for medium and high speeds.

VS020 is **uncoated to ensure a sharper cutting edge**, crucial for very small parts when the cutting speeds are relatively low and light cutting is required.

Grade	Application	Sample
VPG	Sub-micron substrate for a wide range of applications. Excellent anti-fracture resistance. AlTiN PVD coated P20, for medium to high cutting speeds. Excellent for alloy steel, stainless steel, and Titanium.	
VS020	Uncoated Sub-micron substrate for a wide range of applications. Excellent anti-fracture resistance. Recommended for medium to low cutting speeds. Excellent for alloy steel, stainless steel, and Titanium.	

Cutting Recommendations and Tool Types

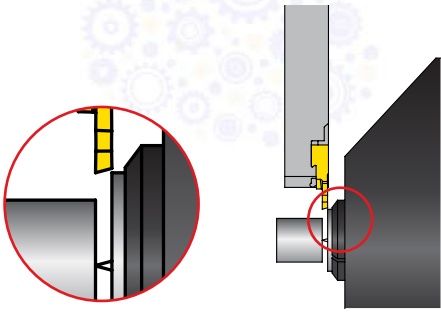

Figure 1:
Parting Off Close to Main Spindle -
STER...-85 RH tool with RH insert/RH
lead angle

When parting off small diameter parts, without the support of the sub spindle, it is recommended to use an ST-Cut Parting Off insert with a lead angle, thereby eliminating the center boss (See Figure 1).

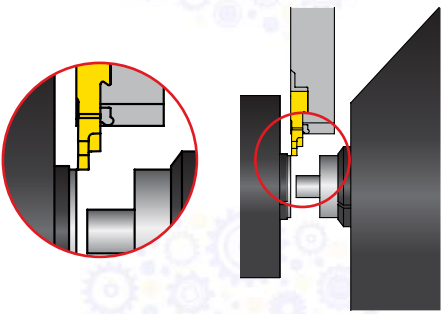

Figure 2:
Parting Off Close to Sub Spindle -
STEL...-85 LH tool with LH insert

When a sub spindle is used, which is the recommended method when parting off small parts, a neutral insert with a tougher notch is recommended to avoid scratches and burrs on the sides of the workpiece (See Figure 2).

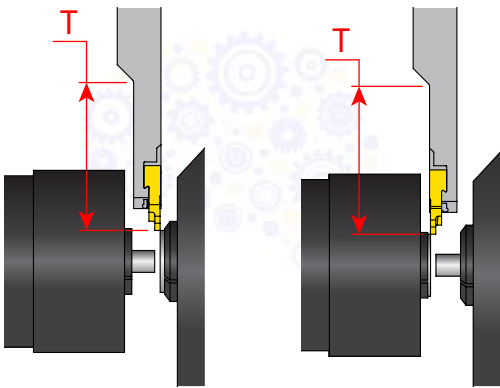

Figure 3:
Parting Off Close
to Main Spindle –
STESR...-85 RH tool
with RH insert
(LH tool also available)

Figure 4:
Parting Off Close to Sub
Spindle – STESRS...-85
RH tool with LH insert

The ST-Cut tool offering includes “Stepped Tools” – STESR/L and STESRS – for short part lengths, where both the main and the sub-spindles are used. The maximum length exceeding the center of the workpiece is 0.20mm (See Figures 3 and 4).



ST-Cut Recommended Cutting Speeds

In bar-feeder machines (Swiss Type, Slide Machines, etc.), turn speed limitations of the bar feeder often dictate the actual cutting speed.

The recommended cutting speeds in the table below should be used if the machine can achieve such speeds.

ST-Cut tools are also designed to work at much lower speeds, and up to 40% faster if needed, depending on the material properties, such as hardness and tensile strength.

Material Group	Vargus No.	Material	Vc [m/min]		
			Turning	Parting Off	Threading
P Steel	1	Unalloyed Steel Low Carbon Steel	150	110	150
	2				
	3				
	4	Low Alloy Steel Alloy Steel < 750 Rm [N/mm ²]	100	75	100
	5				
	6				
	7	High Alloy Steel Alloy Steel > 750 Rm [N/mm ²]	75	55	75
	8				
	9				
M Stainless Steel	11	Stainless Steel	65	50	65
	12				
N(K) Non-Ferrous Metals	34	Aluminum Alloys Aluminum Si > 12%	500	380	200
	35				
	36				
	37	Copper and Copper Alloys Brass, Bronze	350	250	150
	39				
S(M) Heat Resistant Material	19	High Temperature Alloys and Titanium Alloys	60	40	50
	20				
	21				
	22	Titanium > 900 Rm [N/mm ²]	35	30	35
	23				
	24				



ST-Cut Nominal Feeds and Depth of Cut

The cutting conditions for Parting Off and Turning applications in the table below are recommended starting points, which may be increased by up to 30%, depending on material properties, such as hardness and tensile strength.

Material Group	Vargus No.	Material	Cutting Width (mm)	Parting Off	Turning		
				Feed (mm/rev)	Depth of Cut (mm)	Feed (mm/rev)	
P Steel	1	Unalloyed Steel Low Carbon Steel	0.5 - 1.0	0.04	0.05 - 1.2	0.06	
	2		1.2 - 1.8	0.08	1.2 - 2.5	0.12	
	3		2.0 - 3.0	0.12	2.5 - 4.0	0.18	
	4	Low Alloy Steel Alloy Steel < 750 Rm [N/mm ²]	0.5 - 1.0	0.03	0.05 - 1.2	0.04	
	5		1.2 - 1.8	0.06	1.2 - 2.5	0.08	
	6		2.0 - 3.0	0.10	2.5 - 4.0	0.14	
	7	High Alloy Steel Alloy Steel > 750 Rm [N/mm ²]	0.5 - 1.0	0.02	0.05 - 1.2	0.03	
	8		1.2 - 1.8	0.05	1.2 - 2.5	0.08	
	9		2.0 - 3.0	0.08	2.5 - 4.0	0.12	
M Stainless Steel	11	Stainless Steel	0.5 - 1.0	0.025	0.04 - 0.08	0.04	
	12		1.2 - 1.8	0.035	0.08 - 1.5	0.05	
			2.0 - 3.0	0.06	1.5 - 3.0	0.08	
N(K) Non-Ferrous Metals	34	Aluminum Alloys Aluminum Si > 12%	0.5 - 1.0	0.06	0.05 - 1.2	0.08	
	35		1.2 - 1.8	0.12	1.2 - 2.5	0.18	
	36		2.0 - 3.0	0.18	2.5 - 4.0	0.25	
	37	Copper and Copper Alloys Brass, Bronze	0.5 - 1.0	0.06	0.05 - 1.2	0.08	
	39		1.2 - 1.8	0.12	1.2 - 2.5	0.18	
	40		2.0 - 3.0	0.18	2.5 - 4.0	0.25	
S(M) Heat Resistant Material	19	High Temperature Alloys and Titanium Alloys	Titanium < 600 Rm [N/mm ²]	0.5 - 1.0	0.02	0.04 - 0.08	0.03
	20		1.2 - 1.8	0.04	0.08 - 1.5	0.06	
	21		2.0 - 3.0	0.06	1.5 - 3.0	0.10	
	22	Titanium > 900 Rm [N/mm ²]	0.5 - 1.0	0.01	0.04 - 0.08	0.02	
	23		1.2 - 1.8	0.025	0.08 - 1.5	0.04	
	24		2.0 - 3.0	0.04	1.5 - 3.0	0.08	



ST-Cut Inserts

Parting Off.....	52
Groove & Turn.....	54
Square Grooving.....	55
Round Grooving.....	56
Threading.....	57

ST-Cut Inserts - Ordering Code System

ST	85	R	P	00	-	0.7		35	00	-	00	R	E	
1	2	3	4	5		6	7	8	9		10	11	12	13

1 - Line Name ST - ST Cut	2 - Max. Radial Depth 85 - 8.5mm	3 - RH or LH R - Right Hand L - Left Hand	4 - Application P - Parting Off T - Groove Turn S - Square Grooving R - Round Grooving TH - Threading FT - Front Turning BT - Back Turning FG - Face Grooving Internal FP - Face Grooving External	5 - Rake Angle 0 - 0° 6 - 6° 8 - 8° 10 - 10° 12 - 12° 15 - 15° 17 - 17°
-------------------------------------	--	--	--	---

6 - Grooving Width 0.5 - 3.0mm	7 - Thread Standard and Pitch (Threading) 60 - Partial 60° 55 - Partial 55°	8 - t max 15 - 1.5mm 35 - 3.5mm 50 - 5.0mm 55 - 5.5mm 70 - 7.0mm 85 - 8.5mm	9 - Corner Radius 00 - 0.0mm 0.05 - 0.05mm
6 - Corner Radius for Round Grooving Inserts 0.2 - 1.5mm			

10 - Approach Angle (for Parting Off) 00 - 0° 06 - 6° 15 - 15°	11 - Corner Lead Direction (Parting Off) R - Right Hand Direction L - Left Hand Direction None - Neutral Direction	12 - Special Insert Structure E - Treated Cutting Edge W - Wiper C - Chamfer CW - Chamfer & Wiper RW - Radius & Wiper	13 - Grade VPG VS020
	11 - Helix Side (Threading) RH - Right Hand Helix LH - Left Hand Helix	12 - Threading R - Close to Right Shoulder L - Close to Left Shoulder None - Neutral	

ТОВ «СМАРТТЕК ІНЖИНІРИНГ», Т. +380-50-396-90-96, info@smarttec.com.ua, https://www.smarttec.com.ua



Parting Off

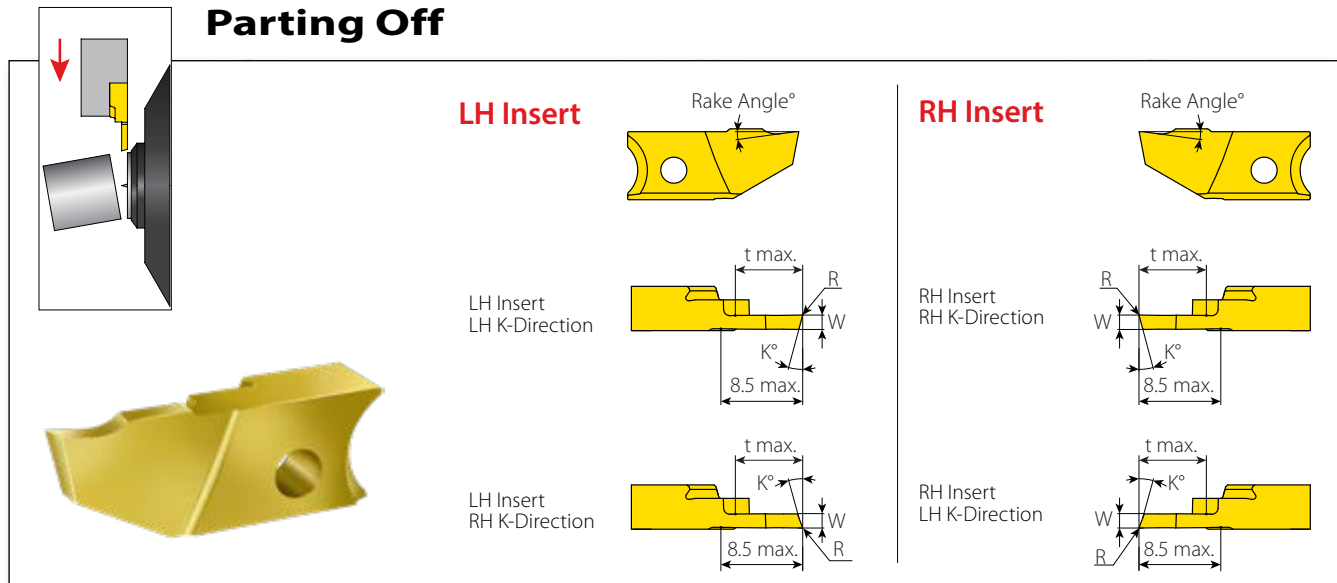

Ordering Code	Dimensions mm						Special Structure	Grade	
	W	R	t max	K°	K° - Direction	Rake Angle		VS020	VPG
ST85RP0-0.515-00-15R	0.50	0	1.50	15	R	0	-	o	•
ST85LP0-0.515-00-15L	0.50	0	1.50	15	L	0	-	o	•
ST85RP0-0.735-00-06RE	0.70	0	3.50	6	R	0	E	o	•
ST85LP0-0.735-00-06LE	0.70	0	3.50	6	L	0	E	o	•
ST85RP0-1.050-00-06RE	1.00	0	5.00	6	R	0	E	o	•
ST85LP0-1.050-00-06LE	1.00	0	5.00	6	L	0	E	o	•
ST85RP0-1.550-00-15RE	1.50	0	5.00	15	R	0	E	o	•
ST85LP0-1.550-00-15LE	1.50	0	5.00	15	L	0	E	o	•
ST85RP0-1.570-0.05-15RE	1.50	0.05	7.00	15	R	0	E	o	•
ST85LP0-1.570-0.05-15LE	1.50	0.05	7.00	15	L	0	E	o	•
ST85RP0-2.085-00-15RE	2.00	0	8.50	15	R	0	E	o	•
ST85LP0-2.085-00-15LE	2.00	0	8.50	15	L	0	E	o	•
ST85RP0-2.085-0.05-15RE	2.00	0.05	8.50	15	R	0	E	o	•
ST85LP0-2.085-0.05-15LE	2.00	0.05	8.50	15	L	0	E	o	•
ST85RP8-0.735-00-15RE	0.70	0	3.50	15	R	8	E	o	•
ST85LP8-0.735-00-15LE	0.70	0	3.50	15	L	8	E	o	•
ST85RP8-1.050-00-15RE	1.00	0	5.00	15	R	8	E	o	•
ST85LP8-1.050-00-15LE	1.00	0	5.00	15	L	8	E	o	•
ST85RP8-0.735-00-15R	0.70	0	3.50	15	R	8	-	o	•
ST85LP8-0.735-00-15L	0.70	0	3.50	15	L	8	-	o	•
ST85RP8-1.050-00-15R	1.00	0	5.00	15	R	8	-	o	•
ST85LP8-1.050-00-15L	1.00	0	5.00	15	L	8	-	o	•
ST85RP8-1.570-00-15RE	1.50	0	7.00	15	R	8	E	o	•
ST85LP8-1.570-00-15LE	1.50	0	7.00	15	L	8	E	o	•
ST85RP8-1.570-0.05-15RE	1.50	0.05	7.00	15	R	8	E	o	•
ST85RP8-1.570-0.05-15LE	1.50	0.05	7.00	15	L	8	E	o	•
ST85RP8-2.085-00-15RE	2.00	0	8.50	15	R	8	E	o	•
ST85LP8-2.085-00-15LE	2.00	0	8.50	15	L	8	E	o	•
ST85RP8-2.085-0.05-15RE	2.00	0.05	8.50	15	R	8	E	o	•
ST85LP8-2.085-0.05-15LE	2.00	0.05	8.50	15	L	8	E	o	•

• In stock o Available upon request



Parting Off

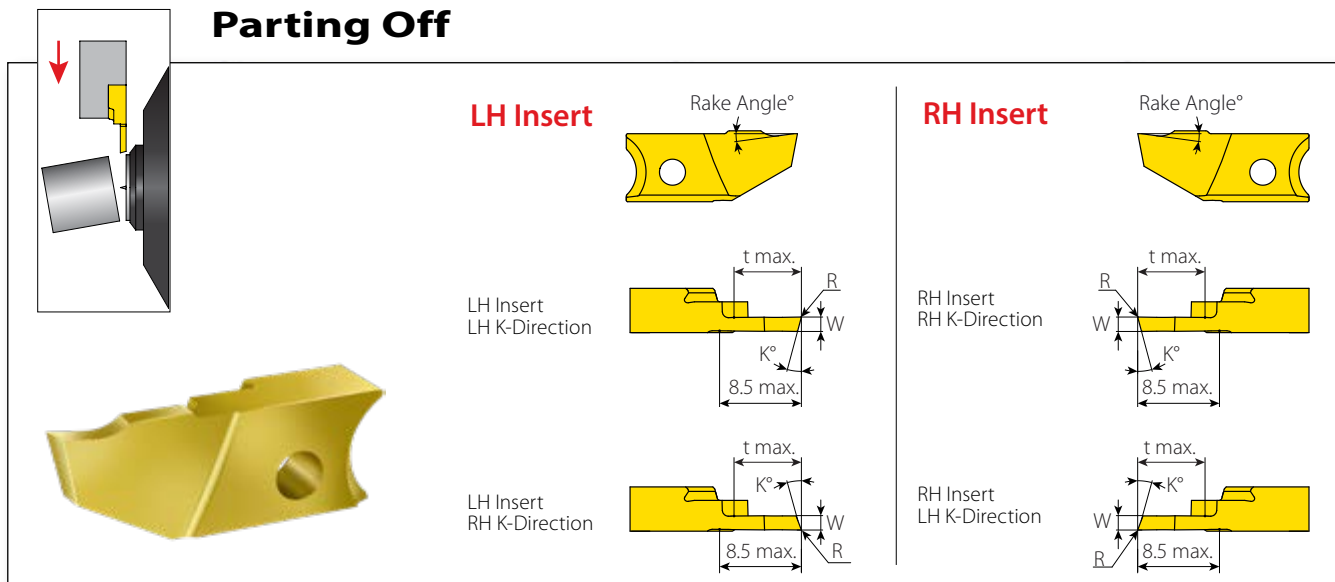

Ordering Code	Dimensions mm						Special Structure	Grade	
	W	R	t max	K°	K° - Direction	Rake Angle		VS020	VPG
ST85RP17-0.735-00-15RE	0.70	0	3.50	15	R	17	E	o	•
ST85LP17-0.735-00-15LE	0.70	0	3.50	15	L	17	E	o	•
ST85RP17-1.050-00-15RE	1.00	0	5.00	15	R	17	E	o	•
ST85LP17-1.050-00-15LE	1.00	0	5.00	15	L	17	E	o	•
ST85RP17-1.570-00-15RE	1.50	0	7.00	15	R	17	E	o	•
ST85LP17-1.570-00-15LE	1.50	0	7.00	15	L	17	E	o	•
ST85RP17-1.570-0.05-15RE	1.50	0.05	7.00	15	R	17	E	o	•
ST85RP17-1.570-0.05-15LE	1.50	0.05	7.00	15	L	17	E	o	•
ST85RP17-2.085-00-15RE	2.00	0	8.50	15	R	17	E	o	•
ST85LP17-2.085-00-15LE	2.00	0	8.50	15	L	17	E	o	•
ST85RP17-2.085-0.05-15RE	2.00	0.05	8.50	15	R	17	E	o	•
ST85LP17-2.085-0.05-15LE	2.00	0.05	8.50	15	L	17	E	o	•

■ In stock ○ Available upon request

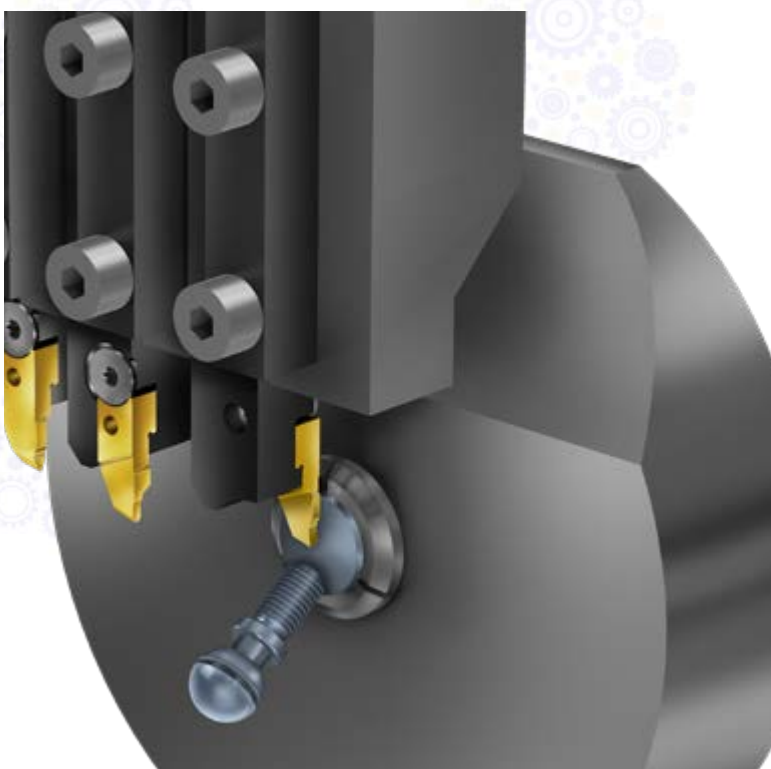

Groove & Turn

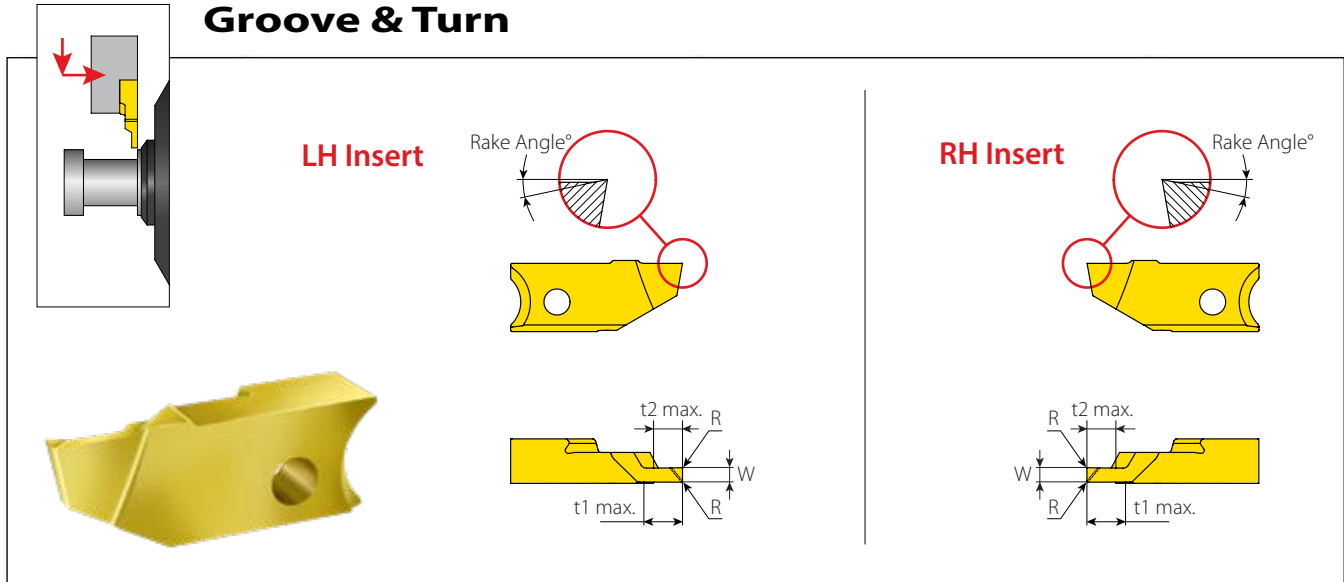

Groove & Turn Right Hand Inserts

Ordering Code	Dimensions mm					Special Structure	Grade	
	W	R	t1 max	t2 max	Rake Angle		VS020	VPG
ST85RT12-0.515-0.03E	0.50	0.03	4.00	1.50	12	E	○	●
ST85RT12-1.025-00E	1.00	0.00	4.00	2.50	12	E	○	●
ST85RT12-1.025-0.05E	1.00	0.05	4.00	2.50	12	E	○	●
ST85RT12-1.530-00E	1.50	0.00	4.00	3.00	12	E	○	●
ST85RT12-1.530-0.08E	1.50	0.08	4.00	3.00	12	E	○	●
ST85RT12-2.040-0.08E	2.00	0.08	6.50	4.00	12	E	○	●
ST85RT12-2.560-0.10E	2.50	0.10	6.50	6.00	12	E	○	●
ST85RT12-3.065-0.20E	3.00	0.20	6.50	6.50	12	E	○	●

● In stock ○ Available upon request

Groove & Turn Left Hand Inserts

Ordering Code	Dimensions mm					Special Structure	Grade	
	W	R	t1 max	t2 max	Rake Angle		VS020	VPG
ST85LT12-0.515-0.03E	0.50	0.03	4.00	1.50	12	E	○	●
ST85LT12-1.025-00E	1.00	0.00	4.00	2.50	12	E	○	●
ST85LT12-1.025-0.05E	1.00	0.05	4.00	2.50	12	E	○	●
ST85LT12-1.530-00E	1.50	0.00	4.00	3.00	12	E	○	●
ST85LT12-1.530-0.08E	1.50	0.08	4.00	3.00	12	E	○	●
ST85LT12-2.040-0.08E	2.00	0.08	6.50	4.00	12	E	○	●
ST85LT12-2.560-0.10E	2.50	0.10	6.50	6.00	12	E	○	●
ST85LT12-3.065-0.20E	3.00	0.20	6.50	6.50	12	E	○	●

● In stock ○ Available upon request

Square Grooving

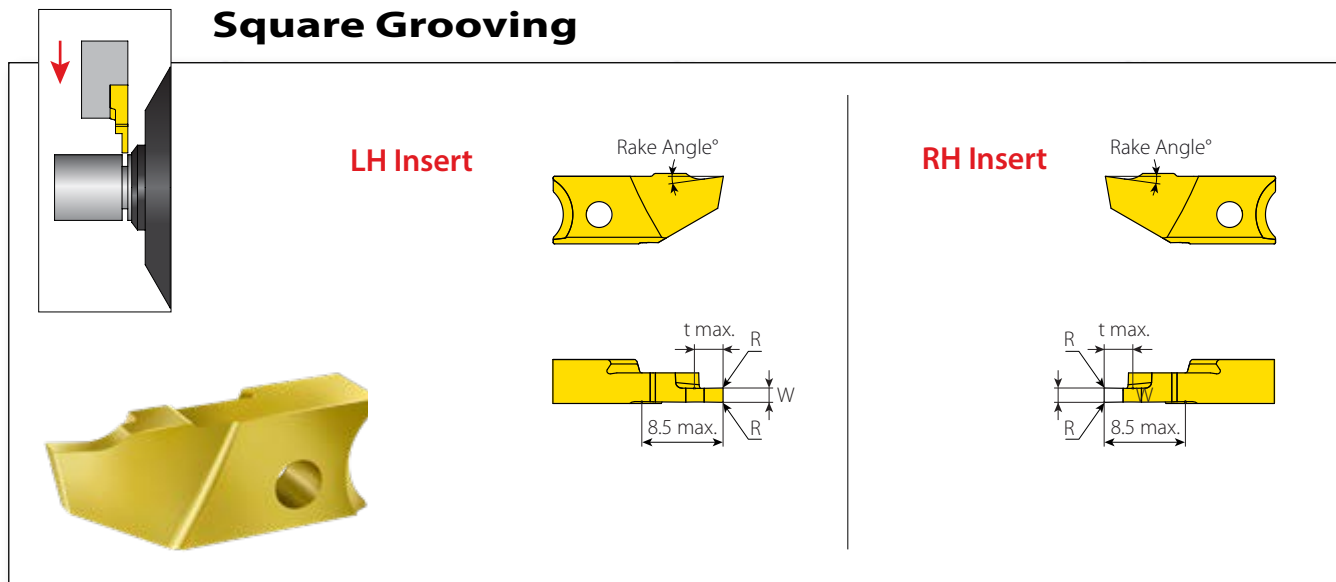

Square Grooving Right Hand Inserts

Ordering Code	Dimensions mm				Special Structure	Grade	
	W	R	t max.	Rake Angle		VS020	VPG
ST85RS0-0.820-00E	0.80	0.00	2.00	0	E	○	●
ST85RS8-0.820-00E	0.80	0.00	2.00	8	E	○	●
ST85RS0-1.025-00E	1.00	0.00	2.50	0	E	○	●
ST85RS8-1.025-00E	1.00	0.00	2.50	8	E	○	●
ST85RS8-1.025-0.05E	1.00	0.05	2.50	8	E	○	●
ST85RS0-1.230-00E	1.20	0.00	3.00	0	E	○	●
ST85RS8-1.230-00E	1.20	0.00	3.00	8	E	○	●
ST85RS0-1.530-00E	1.50	0.00	3.00	0	E	○	●
ST85RS8-1.530-00E	1.50	0.00	3.00	8	E	○	●
ST85RS8-1.530-0.05E	1.50	0.05	3.00	8	E	○	●
ST85RS0-1.840-00E	1.80	0.00	4.00	0	E	○	●
ST85RS0-2.040-00E	2.00	0.00	4.00	0	E	○	●
ST85RS0-2.560-00E	2.50	0.00	6.00	0	E	○	●
ST85RS0-3.065-00E	3.00	0.00	6.50	0	E	○	●

● In stock ○ Available upon request

Square Grooving Left Hand Inserts

Ordering Code	Dimensions mm				Special Structure	Grade	
	W	R	t max.	Rake Angle		VS020	VPG
ST85LS0-0.820-00E	0.80	0.00	2.00	0	E	○	●
ST85LS8-0.820-00E	0.80	0.00	2.00	8	E	○	●
ST85LS0-1.025-00E	1.00	0.00	2.50	0	E	○	●
ST85LS8-1.025-00E	1.00	0.00	2.50	8	E	○	●
ST85LS8-1.025-0.05E	1.00	0.05	2.50	8	E	○	●
ST85LS0-1.230-00E	1.20	0.00	3.00	0	E	○	●
ST85LS8-1.230-00E	1.20	0.00	3.00	8	E	○	●
ST85LS0-1.530-00E	1.50	0.00	3.00	0	E	○	●
ST85LS8-1.530-00E	1.50	0.00	3.00	8	E	○	●
ST85LS8-1.530-0.05E	1.50	0.05	3.00	8	E	○	●
ST85LS0-1.840-00E	1.80	0.00	4.00	0	E	○	●
ST85LS0-2.040-00E	2.00	0.00	4.00	0	E	○	●
ST85LS0-2.560-00E	2.50	0.00	6.00	0	E	○	●
ST85LS0-3.065-00E	3.00	0.00	6.50	0	E	○	●

● In stock ○ Available upon request

Round Grooving

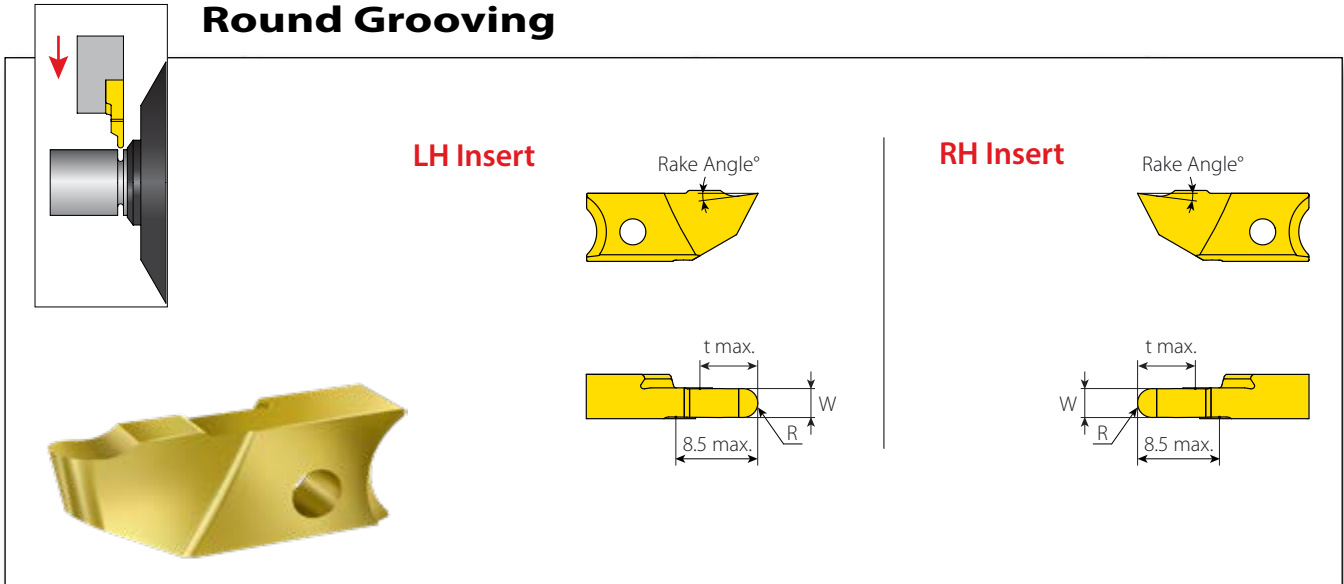

Round Grooving Right Hand Inserts

Ordering Code	Dimensions mm				Special Structure	Grade	
	W	R	t max	Rake Angle		VS020	VPG
ST85RR0-0.215E	0.40	0.20	1.50	0	E	○	●
ST85RR0-0.520E	1.00	0.50	2.00	0	E	○	●
ST85RR0-0.7530E	1.50	0.75	3.00	0	E	○	●
ST85RR0-1.040E	2.00	1.00	4.00	0	E	○	●
ST85RR8-1.040E	2.00	1.00	4.00	8	E	○	●
ST85RR0-1.2550E	2.50	1.25	5.00	0	E	○	●
ST85RR0-1.560E	3.00	1.50	6.00	0	E	○	●
ST85RR8-1.560E	3.00	1.50	6.00	8	E	○	●

● In stock ○ Available upon request

Round Grooving Left Hand Inserts

Ordering Code	Dimensions mm				Special Structure	Grade	
	W	R	t max	Rake Angle		VS020	VPG
ST85LR0-0.215E	0.40	0.20	1.50	0	E	○	●
ST85LR0-0.520E	1.00	0.50	2.00	0	E	○	●
ST85LR0-0.7530E	1.50	0.75	3.00	0	E	○	●
ST85LR0-1.040E	2.00	1.00	4.00	0	E	○	●
ST85LR8-1.040E	2.00	1.00	4.00	8	E	○	●
ST85LR0-1.2550E	2.50	1.25	5.00	0	E	○	●
ST85LR0-1.560E	3.00	1.50	6.00	0	E	○	●
ST85LR8-1.560E	3.00	1.50	6.00	8	E	○	●

● In stock ○ Available upon request

THREADING

Partial Profile 60°

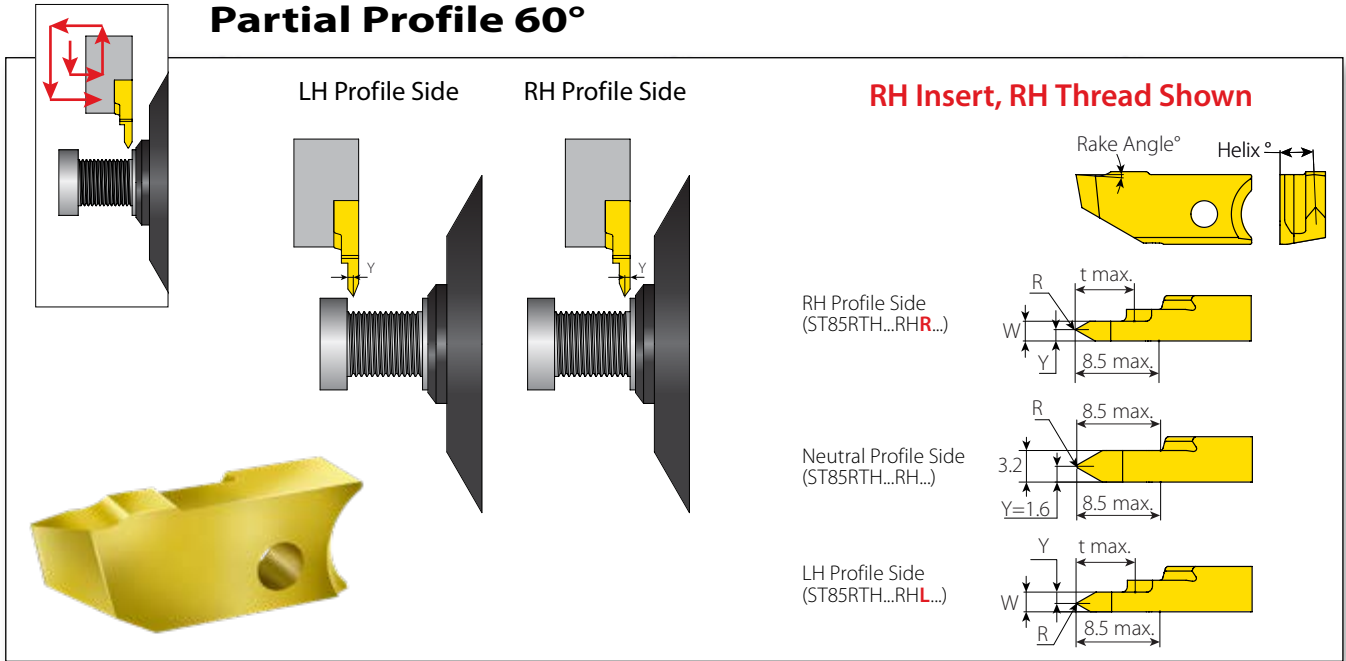

Partial Profile 60° Right Hand Inserts

Ordering Code	Dimensions mm				Pitch mm / TPI	No. of Passes	Rake Angle	Helix °	Thread Direction	Profile Side	Grade	
	W	R	t max	Y							VS020	VPG
ST85RTH4AA60RHR	1.00	0.00	2.50	0.15	0.075 - 0.25/508-100	3-4	4	6	RH	R	○	●
ST85RTH4AA60RHL	1.00	0.00	2.50	0.15	0.075 - 0.25/508-100	3-4	4	6	RH	L	○	●
ST85RTH4AB60RHR	1.50	0.02	4.50	0.30	0.25 - 0.5/80-46	4-6	4	4	RH	R	○	●
ST85RTH4AB60RHL	1.50	0.02	4.50	0.30	0.25 - 0.5/80-46	4-6	4	4	RH	L	○	●
ST85RTH4A60RHR	2.00	0.05	6.5	0.85	0.5 - 1.5/46-16	4-10	4	2.5	RH	R	○	●
ST85RTH4A60RHL	2.00	0.05	6.5	0.85	0.5 - 1.5/46-16	4-10	4	2.5	RH	L	○	●
ST85RTH4G60RH	3.20	0.20	8.5	1.60	1.75 - 3.0/14-8	5-14	4	1.5	RH	N	○	●

● In stock ○ Available upon request

Partial Profile 60° Left Hand Inserts

Ordering Code	Dimensions mm				Pitch mm / TPI	No. of Passes	Rake Angle	Helix °	Thread Direction	Profile Side	Grade	
	W	R	t max	Y							VS020	VPG
ST85LTH4AA60RHR	1.00	0.00	2.50	0.15	0.075 - 0.25/508-100	3-4	4	6	RH	R	○	●
ST85LTH4AA60RHL	1.00	0.00	2.50	0.15	0.075 - 0.25/508-100	3-4	4	6	RH	L	○	●
ST85LTH4AB60RHR	1.50	0.02	4.50	0.30	0.25 - 0.5/80-46	4-6	4	4	RH	R	○	●
ST85LTH4AB60RHL	1.50	0.02	4.50	0.30	0.25 - 0.5/80-46	4-6	4	4	RH	L	○	●
ST85LTH4A60RHR	2.00	0.05	6.5	0.85	0.5 - 1.5/46-16	4-10	4	2.5	RH	R	○	●
ST85LTH4A60RHL	2.00	0.05	6.5	0.85	0.5 - 1.5/46-16	4-10	4	2.5	RH	L	○	●
ST85LTH4G60RH	3.20	0.20	8.5	1.60	1.75 - 3.0/14-8	5-14	4	1.5	RH	N	○	●

● In stock ○ Available upon request

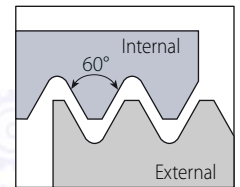

ТОВ «СМАРТТЕК ІНЖИНІРИНГ», Т. +380-50-396-90-96, info@smarttec.com.ua, https://www.smarttec.com.ua

Partial Profile 55°

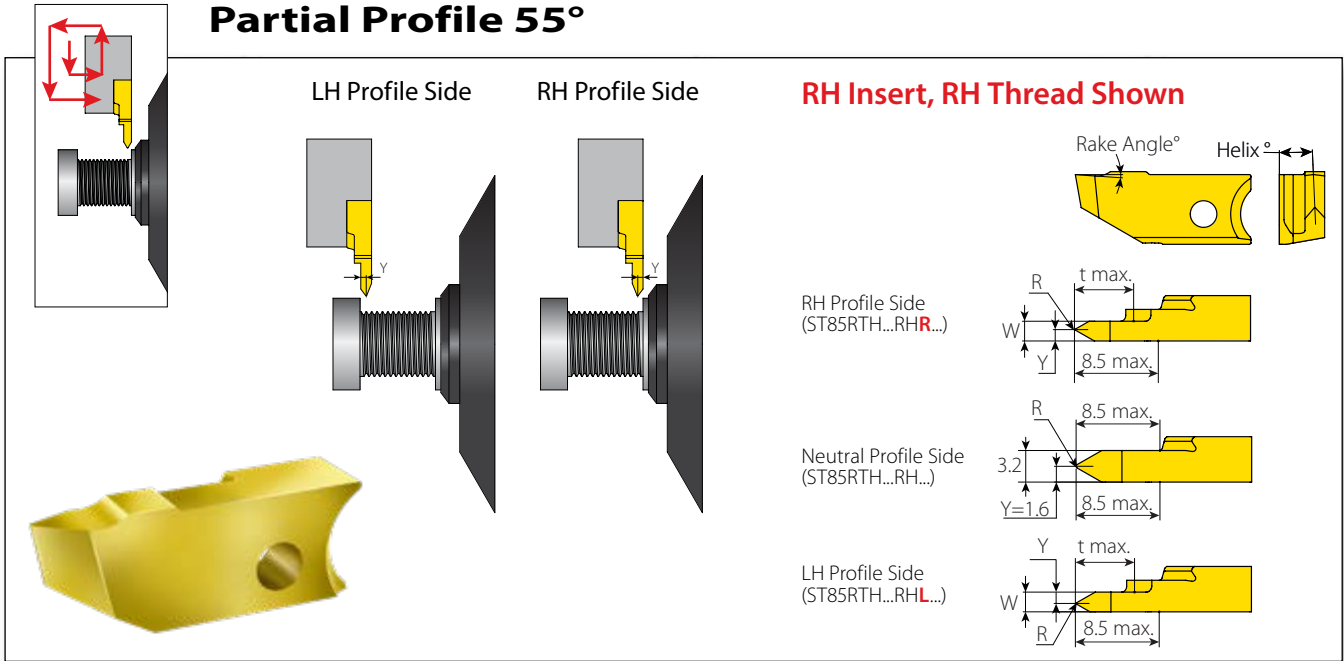

Partial Profile 55° Right Hand Inserts

Ordering Code	Dimensions mm				Pitch mm / TPI	No. of Passes	Rake Angle	Helix °	Thread Direction	Profile Side	Grade	
	W	R	t max	Y							VS020	VPG
ST85RTH4A55RHR	2.00	0.06	6.50	0.85	0.5 - 1.5/46-16	4-10	4	2.5	RH	R	○	●
ST85RTH4A55RHL	2.00	0.06	6.50	0.85	0.5 - 1.5/46-16	4-10	4	2.5	RH	L	○	●
ST85RTH4G55RH	3.20	0.25	8.50	1.60	1.75 - 3.0/14-8	5-14	4	1.5	RH	N	○	●

● In stock ○ Available upon request

Partial Profile 55° Left Hand Inserts

Ordering Code	Dimensions mm				Pitch mm / TPI	No. of Passes	Rake Angle	Helix °	Thread Direction	Profile Side	Grade	
	W	R	t max	Y							VS020	VPG
ST85LTH4A55RHR	2.00	0.06	6.50	0.85	0.5 - 1.5/46-16	4-10	4	2.5	RH	R	○	●
ST85LTH4A55RHL	2.00	0.06	6.50	0.85	0.5 - 1.5/46-16	4-10	4	2.5	RH	L	○	●
ST85LTH4G55RH	3.20	0.25	8.50	1.60	1.75 - 3.0/14-8	5-14	4	1.5	RH	N	○	●

● In stock ○ Available upon request

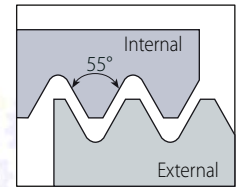

ST-Cut External Tools

Square Shank Tools.....	60
Stepped Square Shank Tools.....	61
Square Shank 90° Tools.....	62

ST-Cut Tools - Ordering Code System

ST	E		SR	810		85	T30	
1	2	3	4	5	-	6	7	8

1- Line Name	2 - Type	3 - Approach Angle	4 - RH or LH
ST - ST Cut	E - Square Shank R - Round Shank	None - 0° 90 - 90° 45 - 45°	R - RH Tool L - LH Tool SR - RH Stepped Shank, Sub spindle relief. See figure 1 SL - LH Stepped Shank, Main spindle relief SRS - RH Stepped Shank. Insert close to Sub spindle (left side). See figure 2 SLS - LH Stepped Shank. Close to Main spindle (right side)

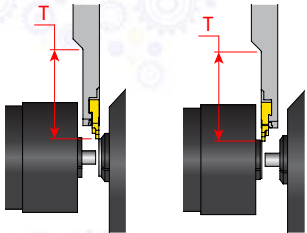



Figure 1
SR Tool - RH tool with RH insert

Figure 2
SRS Tool - RH tool with LH insert

5 - Shank Size / Diameter	6 - Max Radial Depth	7 - Radial Depth Depth (Stepped Toolholders)	8 - Coolant
0810 - 8x10mm 1010 - 10x10mm 1212 - 12x12mm 1616 - 16x16mm 2020 - 20x20mm 10 - Ø10mm	85 - Max Radial Depth 8.5mm	None - Non Stepped Shank T30 - Limit Depth of Step 30mm T40 - Limit Depth of Step 40mm	None - No coolant C - Coolant

Torque Limiting Accessories (Sold Separately):



Torque Limiting Handles

	Ordering Code	Item Number	Range
	VTRF	013-01038	0.6 Nm to 3.0 Nm

Torque Limiting Adapters

	Ordering Code	Item Number	Torque Max (Nm)
	D02-12 -3.0Nm	013-01084	3.0

Torque Limiting Bits



	Ordering Code	Item Number	Bit Type
	BIT25-TX10	013-01094	 Torx

ТОВ «СМАРТТЕК ІНЖИНІРИНГ», Т. +380-50-396-90-96, info@smarttec.com.ua, https://www.smarttec.com.ua

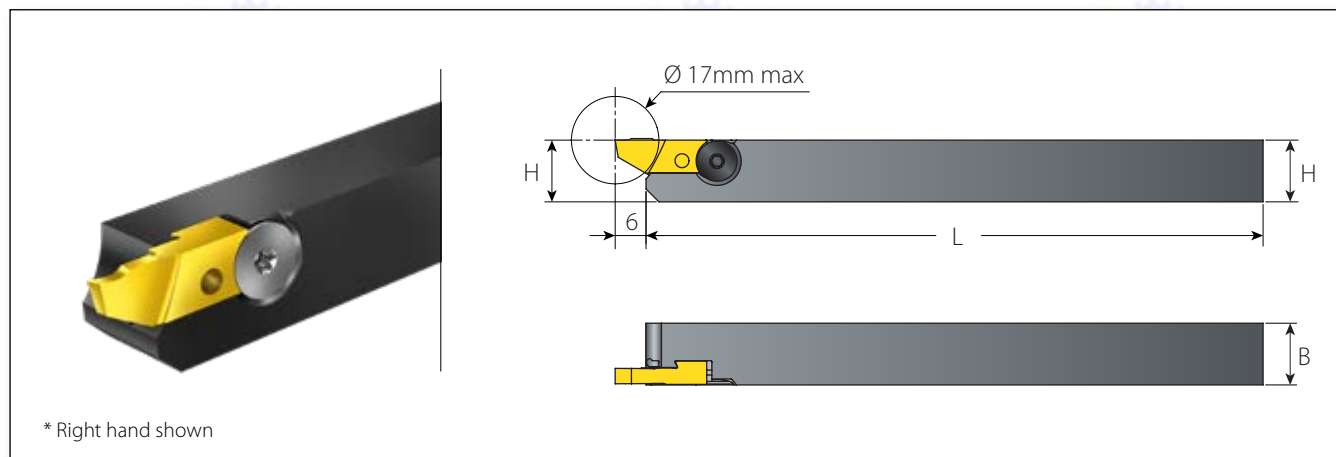

Square Shank Tools



Square Shank **Right Hand** Tools

Insert Size	Ordering Code	Dimensions mm		Spare Parts		
		HxB	L			
85	STER0810-85	8x10	110	SM5x0.8x9-T10 LH Torque Limit: 3.0Nm	K3T	D02-12-3.0Nm
	STER1010-85	10x10	110			
	STER1212-85	12x12	120			
	STER1616-85	16x16	120			
	STER2020-85	20x20	120			

Square Shank **Left Hand** Tools

Insert Size	Ordering Code	Dimensions mm		Spare Parts		
		HxB	L			
85	STEL0810-85	8x10	110	SM5x0.8x9-T10 Torque Limit: 3.0Nm	K3T	D02-12-3.0Nm
	STEL1010-85	10x10	110			
	STEL1212-85	12x12	120			
	STEL1616-85	16x16	120			
	STEL2020-85	20x20	120			

* Item sold separately. See page 59 for more details.



Stepped Square Shank Tools

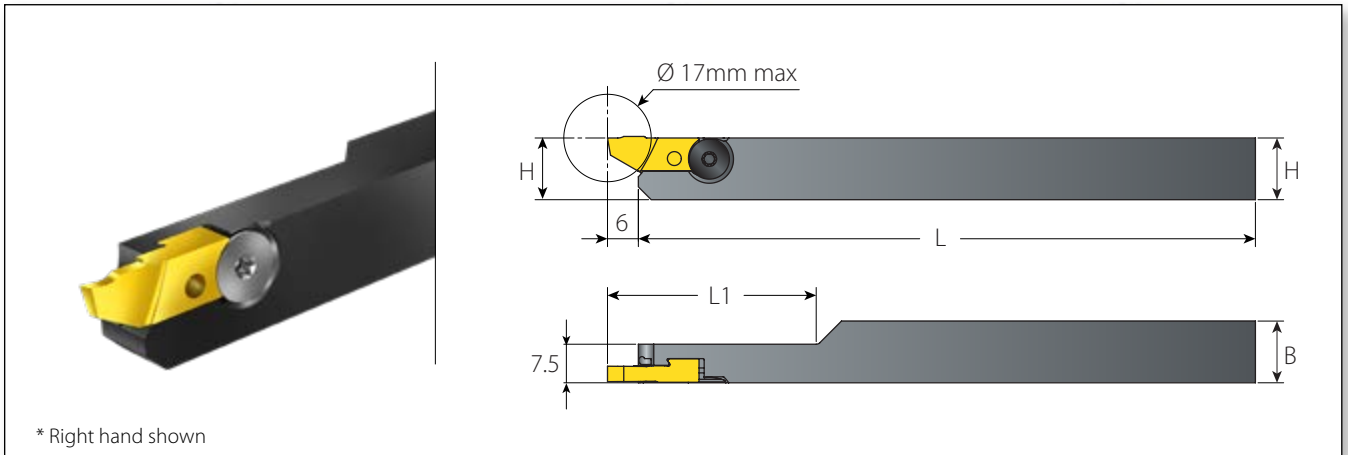

* Right hand shown

Stepped Square Shank Right Hand Tools (STESR)

Spare Parts

Insert Size	Ordering Code	Dimensions mm			Screw	Key	Torque Limiting Adapter*
		HxB	L	L1			
85	STESR0810-85T30	08x10	110	30	SM5x0.5x7-T10 LH Torque Limit: 3.0Nm	K3T	D02-12-3.0Nm
	STESR1010-85T30	10x10	110	30			
	STESR1212-85T40	12x12	120	40			
	STESR1616-85T40	16x16	120	40			

Stepped Square Shank Left Hand Tools (STESL)

Spare Parts

Insert Size	Ordering Code	Dimensions mm			Screw	Key	Torque Limiting Adapter*
		HxB	L	L1			
85	STESL0810-85T30	08x10	110	30	SM5x0.5x7-T10 Torque Limit: 3.0Nm	K3T	D02-12-3.0Nm
	STESL1010-85T30	10x10	110	30			
	STESL1212-85T40	12x12	120	40			
	STESL1616-85T40	16x16	120	40			

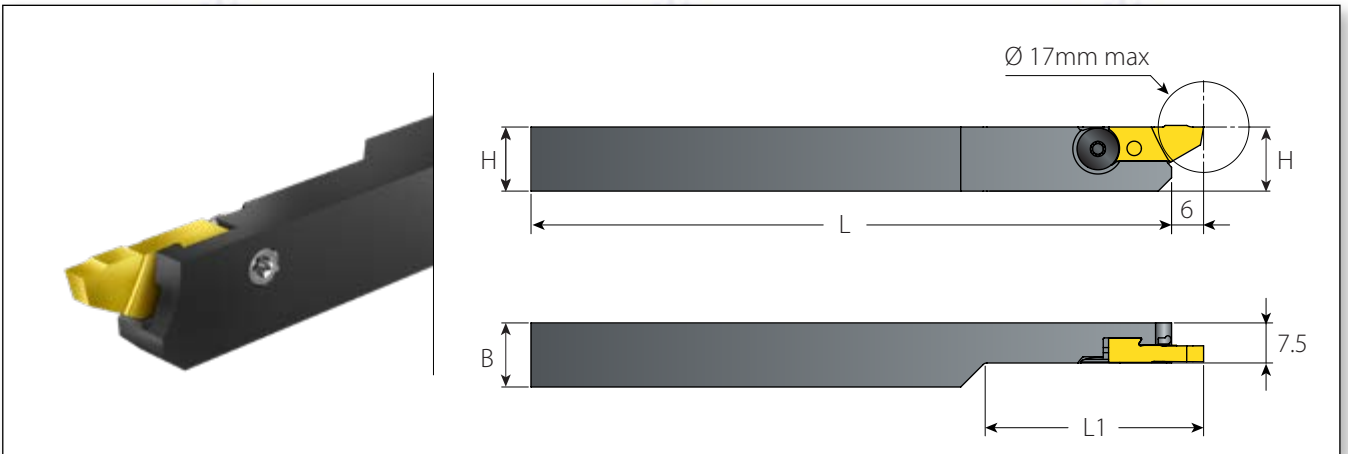

Stepped Square Shank Right Hand Tools (STESRS) **

Spare Parts

Insert Size	Ordering Code	Dimensions mm			Screw	Key	Torque Limiting Adapter*
		HxB	L	L1			
85	STESRS1010-85T30	10x10	110	30	SM5x0.5x7-T10 Torque Limit: 3.0Nm	K3T	D02-12-3.0Nm
	STESRS1212-85T40	12x12	120	40			
	STESRS1616-85T40	16x16	120	40			

* Item sold separately. See page 59 for more details.

** STESRS...-85T... - RH tool with LH Inserts. See page 48.

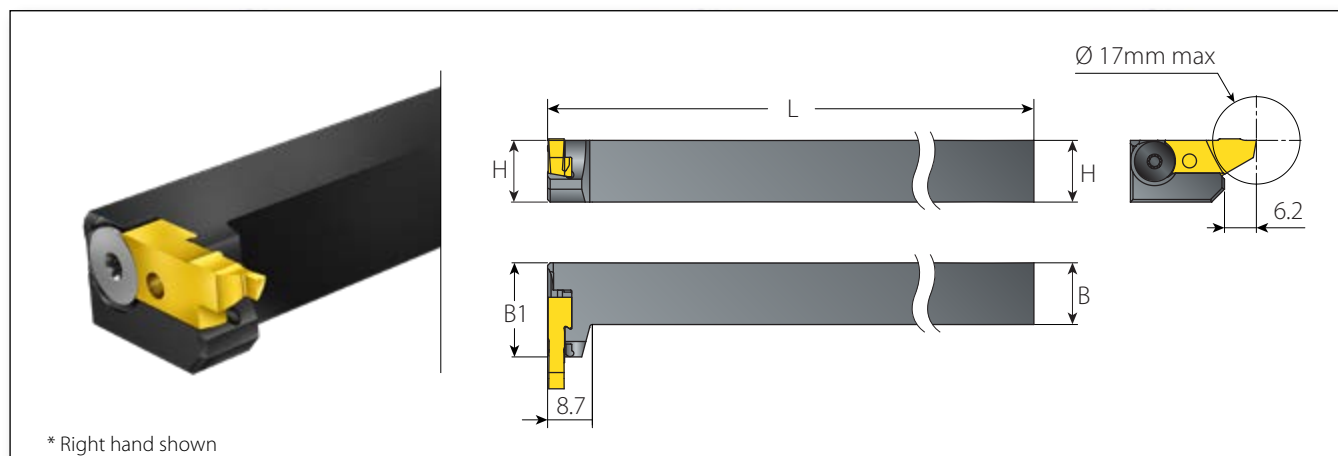

ТОВ «СМАРТТЕК ІНЖИНІРИНГ», Т. +380-50-396-90-96, info@smarttec.com.ua, https://www.smarttec.com.ua

Square Shank 90° Tools



Square Shank 90° Right Hand Tools **

Spare Parts

Insert Size	Ordering Code	Dimensions mm					
		HxB	L	B1	Screw	Key	Torque Limiting Adapter*
85	STE90R1010-85	10x10	110	18.3	SM5x0.8x9-T10 Torque Limit: 3.0Nm	K3T	D02-12-3.0Nm
	STE90R1212-85	12x12	120	18.3			

! * Item sold separately. See page 59 for more details.

! ** STE90R...-85. - RH tool with LH Inserts





EXTERNAL MACHINING | FINISHING

GrooVical

Precise Grooving & Turning Applications

GrooVical

Precise Grooving & Turning Applications

Versatile Range of Indexable Grooving Inserts

The **GrooVical** family of products by Groovex offers improved solutions for precise grooving and turning applications. GVN26 and GV29/GVN29 feature inserts with three cutting corners and a unique rigid clamping system for improved productivity.

The new GVN style inserts offer new applications in the GrooVical line, including Turning and Grooving chip former to form helical chips, spiral chips for grooving, new parting off inserts, machining close to shoulders and left hand toolholders.

GVN26

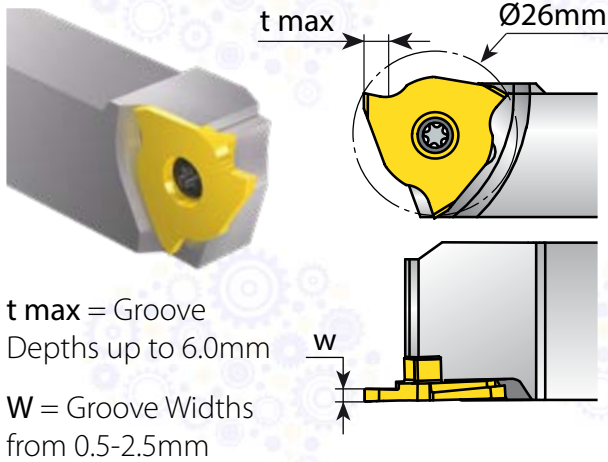

GVN29

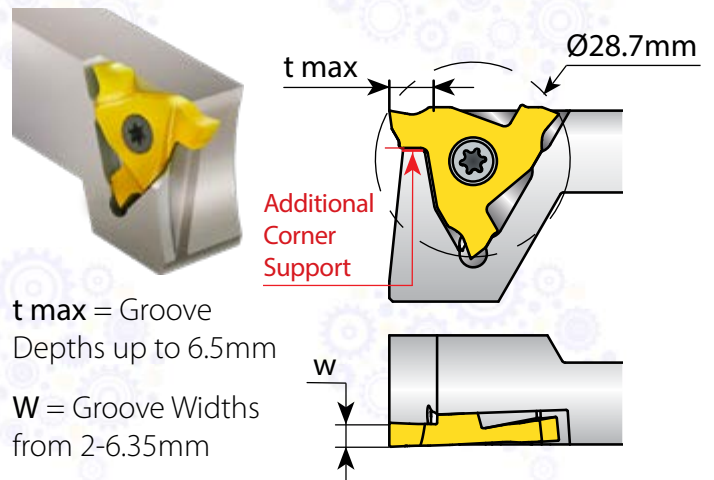

Modular Holders with High Pressure Coolant (HPC)

- Quick change modules for **GrooVical** GVN26 and GVN29 inserts for precise grooving, turning and parting off
- High pressure coolant up to 100 bar
- Modules are suitable for parallel and 90° modular square bodies and the **NEW** GROOVEX polygon shaped V-CAP holders (C4, C5, C6)
- Groovex V-Cap holders are according to ISO 26623

For more information see page 79.



Applications:

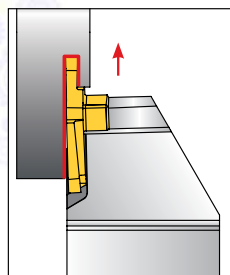

Square Grooving

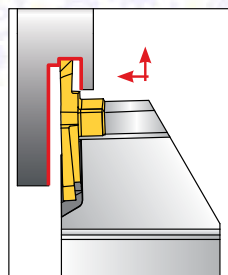

Square Turning & Grooving

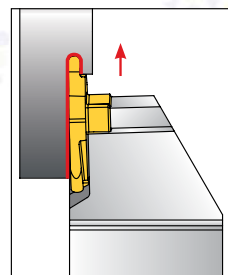

Round Grooving

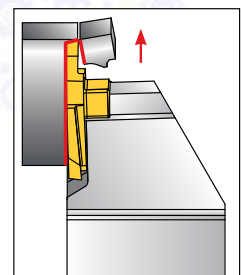

Parting Off



Groovical Technical Data

Recommended Grades and Cutting Data

Material Group	Vargus No.	Material	Hardness Brinell HB	Vc [m/min]	
				Coated	Uncoated
				VKX	VN020
P Steel	1	Unalloyed Steel	Low Carbon (C=0.1-0.25%)	125	140-200
	2		Medium Carbon (C=0.25-0.55%)	150	120-180
	3		High Carbon (C=0.55-0.85%)	170	110-180
	4	Low Alloy Steel (alloying elements ≤ 5%)	Non Hardened	180	100-155
	5		Hardened	275	110-180
	6		Hardened	350	80-135
	7	High Alloy Steel (alloying elements > 5%)	Annealed	200	70-115
	8		Hardened	325	50-100
	9	Cast Steel	Low Alloy (alloying elements < 5%)	200	30-50
	10		High Alloy (alloying elements > 5%)	225	20-40
M Stainless Steel	11	Stainless Steel Ferritic	Non Hardened	200	70-120
	12		Hardened	330	60-95
	13	Stainless Steel Austenitic	Austenitic	180	70-120
	14		Super Austenitic	200	40-90
	15	Stainless Steel Non Hardened	200	80-110	
	16	Cast Ferritic	Hardened	330	65-110
	17	Stainless Steel Austenitic	200	85-100	
	18	Cast Austenitic	Hardened	330	60-100
K Cast Iron	28	Malleable Cast Iron	Ferritic (short chips)	130	70-120
	29		Pearlitic (long chips)	230	70-120
	30	Grey Cast Iron	Low Tensile Strength	180	70-120
	31		High Tensile Strength	260	60-100
	32	Nodular Sg Iron	Ferritic	160	50-80
	33		Pearlitic	260	60-90
N(K) Non-Ferrous Metals	34	Aluminum Alloys Wrought	Non Aging	60	-
	35		Aged	100	-
	36	Aluminum Alloys	Cast	75	-
	37		Cast & Aged	90	-
	38	Aluminum Alloys	Cast Si 13-22%	130	-
	39	Copper and Copper Alloys	Brass	90	-
	40		Bronze And Non Leaded Copper	100	-
	S(M) Heat Resistant Material	19	High Temperature Alloys	Annealed (iron based)	200
20		Aged (iron based)		280	35-50
21		Annealed (nickel or cobalt based)		250	20-30
22		Aged (nickel or cobalt based)		350	15-25
23		Titanium Alloys	Pure 99.5 Ti	400Rm	140-170
24			α+β Alloys	1050Rm	50-70
H(K) Hardened Material	25	Extra Hard Steel	Hardened & Tempered	45-50HRc	45-60
	26			51-55HRc	40-50

The maximum recommended **feed rate** is one-tenth of the insert width (W).

The minimum recommended **depth of cut** is twice the corner radius (r).

VTX

Excellent for Grooving applications in medium-to-high cutting speeds and in dry conditions. Multi-layered AlTiN coated, general purpose grade for prevention of peeling and chipping.

* For **VTX Grade**, increase speed by 20%.

VKX

Standard grade for Grooving applications. Single-layered AlTiN+TiN coated.

VN020

NEW

Uncoated grade specially designed for Aluminum and Copper alloys. The high positive rake geometry and the sharp cutting edge of these inserts produce low forces while machining.

Recommended Feed Rate for Grooving & Turning Finishing Operations

Insert Width (mm)	High Alloy Steel, 330 HB, 2100 Kc [N/mm ²]		Austenitic Stainless Steel, 200 HB, 2600 Kc [N/mm ²]	
	Depth ap = Insert Width x variable	Average f mm/rev	Depth ap = Insert Width x variable	Average f mm/rev
0.4 mm - 0.9 mm	0.55	0.04	0.35	0.02
1.0mm - 1.5mm	0.55	0.07	0.35	0.04
1.6 mm -2.0 mm	0.60	0.11	0.40	0.07
2.1 mm - 2.5 mm	0.60	0.14	0.40	0.09
2.6 mm - 3.0 mm	0.60	0.17	0.40	0.11
3.1 mm - 4.0mm	0.60	0.21	0.40	0.14
4.1 mm - 5.5 mm	0.60	0.28	0.40	0.19

| The above recommendations are for achieving a stable and recurring tool life.

| Exceeding higher feed rates may cause excessive wear and breakage.

D max Limitations

GVN26 External - Depth of Groove in Relation to Workpiece Dia.

D max is 150mm

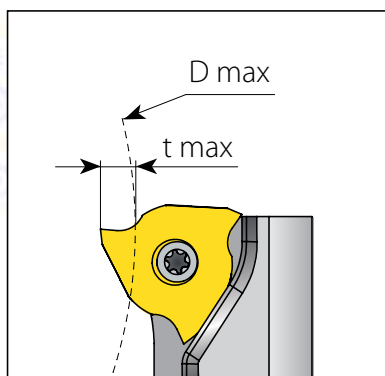

GV29 / GVN29 External - Depth of Groove in Relation to Workpiece Dia.

Dimensions mm	
t max	D max
0.5	1085.0
1	590.0
1.5	408.0
2	310.0
2.5	250.0
3	210.0
3.5	180.0
4	160.0
4.5	145.0
5	130.0
5.5	120.0
6	110.0
6.5	105.0

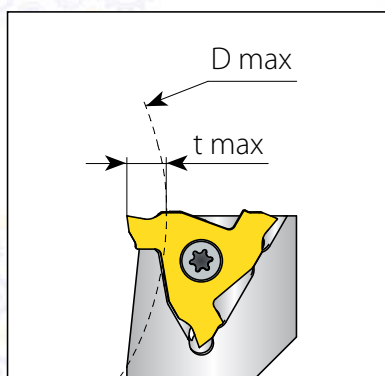

GrooVical Inserts

GVN26 & GVN29 Close to Shoulder:

Super Positive Rake Grooving.....	68
Square Turning & Grooving Chip Former.....	69
Square Grooving.....	70
Round Grooving.....	71
Parting Off.....	72
GV29 Neutral:	
Square Grooving.....	73
Round Grooving.....	74



GrooVical Inserts - Ordering Code System

GVN 1	26 2	R 3	P 4	0.5 5	-	0.05 6	-	15 7	R 8	VKX 9
1 - Insert Type GVN - Groovical Close to Shoulder GV - Groovical Neutral		2 - Circular Circumference 26 - 26 mm 29 - 28.7 mm		3 - RH or LH R - RH L - LH N - RH/LH		4 - Type of Application T - Turning & Grooving S - Square Grooving SP - Positive Rake Grooving R - Round Grooving P - Parting Off X - Special Profile			5 - Grooving Width 0.5 to 6.35mm	
7 - Approach Angle 6 - 6 Deg. 15 - 15 Deg.		8 - Cutting Side R - Right corner leading L - Left corner leading None - Neutral		9 - Carbide Grade VTX, VKX, VN020		6 - Corner Radius 0.0 - 1mm				



Close to Shoulder **Super Positive Rake Grooving (SP)**

NEW

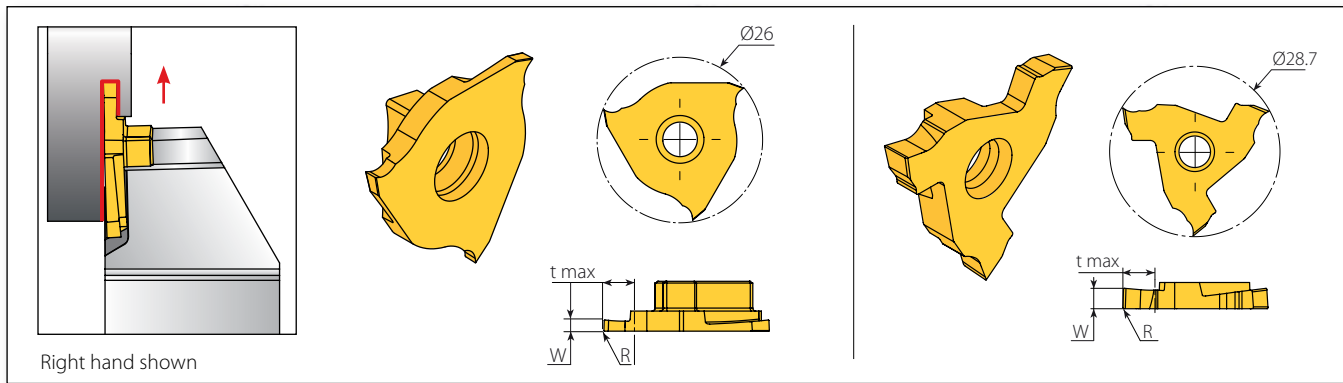

Insert Size	Ordering Code	Dimensions mm			Grade		Toolholder
		W ± 0.02	R ± 0.03	t max	VN020 NEW	VTX	
26	GVN26R/LSP1.0-0.08	1.0	0.08	2.25	•	•	GVNE...-26, GVNE90...-26
	GVN26R/LSP1.5-0.08	1.5	0.08	3.00	•	•	
	GVN26R/LSP2.0-0.1	2.0	0.10	3.75	•	•	
	GVN26R/LSP2.5-0.15	2.5	0.15	3.75	•	•	
29	GVN29R/LSP3.0-0.2	3.0	0.20	4.90	◦	•	GVNE...-29-1, GVNE90...-29-2, GVNI...-29

• In stock ◦ Available upon request

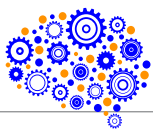
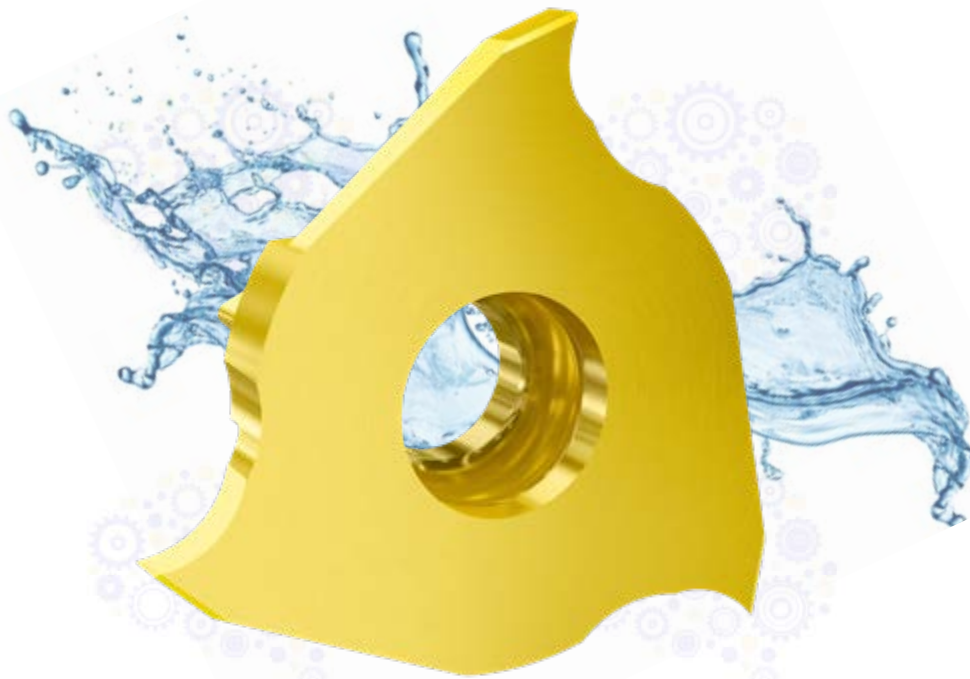

Close to Shoulder **Square Turning & Grooving** Chip Former

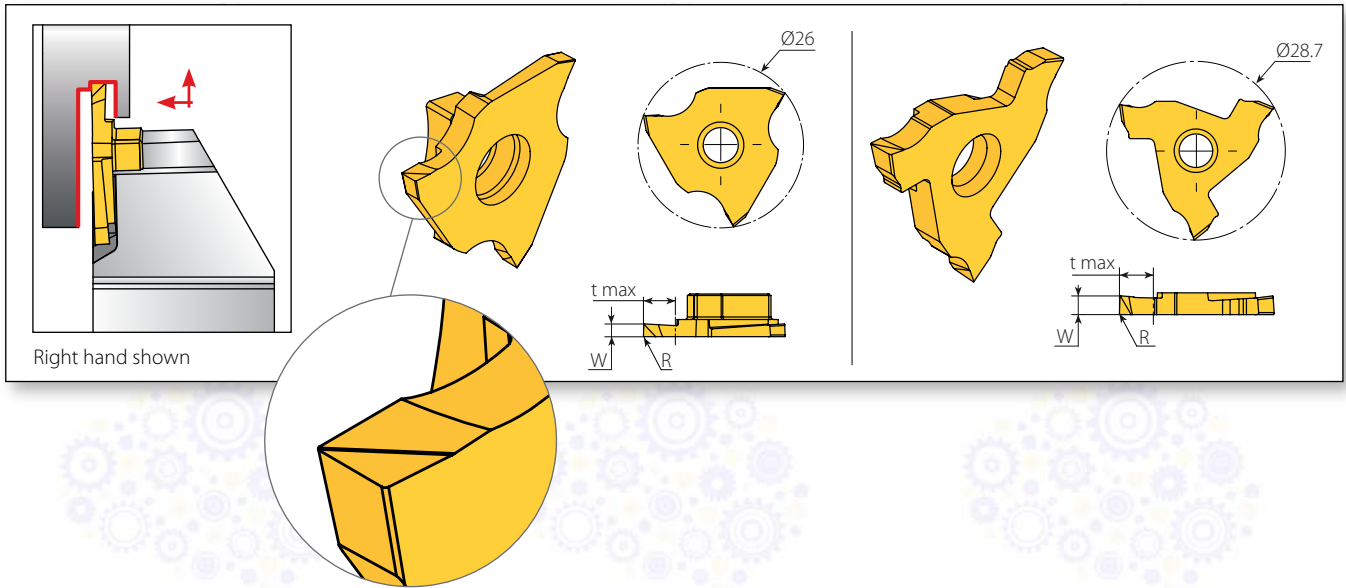

Insert Size	Ordering Code	Dimensions mm			Grade		Toolholder
IC	RH/LH	W ± 0.02	R ± 0.03	t max	VKX	VTX	
26	GVN26R/LT1.0-0.06	1.0	0.06	3.0	◦	•	GVNE...-26, GVNE90...-26
	GVN26R/LT1.0-0.08	1.0	0.08	3.0	◦	•	
	GVN26RT1.0-0.12	1.0	0.12	1.5	◦	•	
	GVN26RT1.4-0.05	1.4	0.05	2.0	◦	•	
	GVN26R/LT1.5-0.08	1.5	0.08	4.0	◦	•	
	GVN26RT1.5-0.20	1.5	0.20	3.0	◦	•	
	GVN26R/LT2.0-0.1	2.0	0.10	5.0	•	•	
	GVN26R/LT2.5-0.15	2.5	0.15	5.0	◦	•	
29	GVN29R/LT3.0-0.2	3.0	0.20	6.5	◦	•	GVNE...-29-1, GVNE90...-29-2, GVNI...-29

• In stock ◦ Available upon request

Close to shoulder machining

Turning and Grooving positive Chip Former, preventing tangled chips around the workpiece

Grooving up to 6.5mm depth

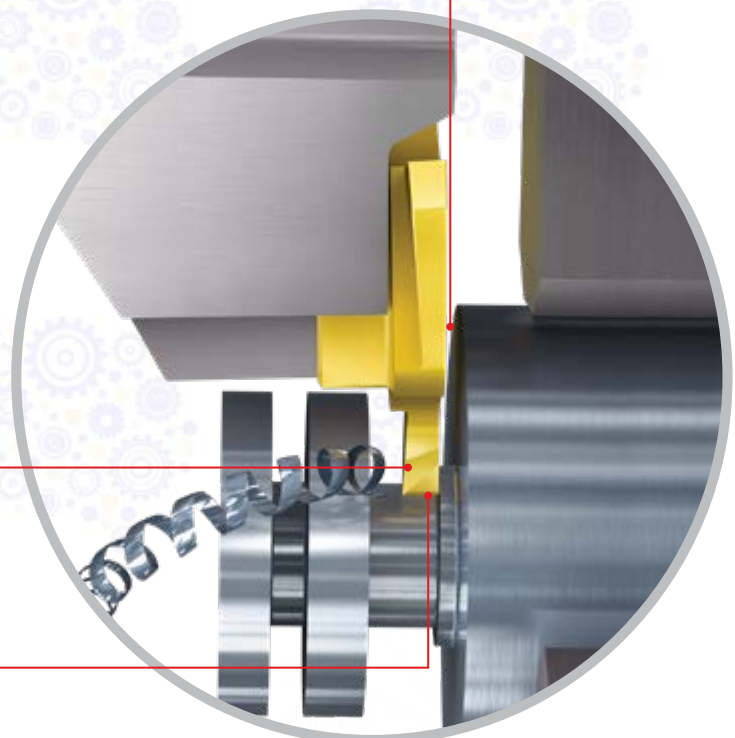

Close to Shoulder Square Grooving

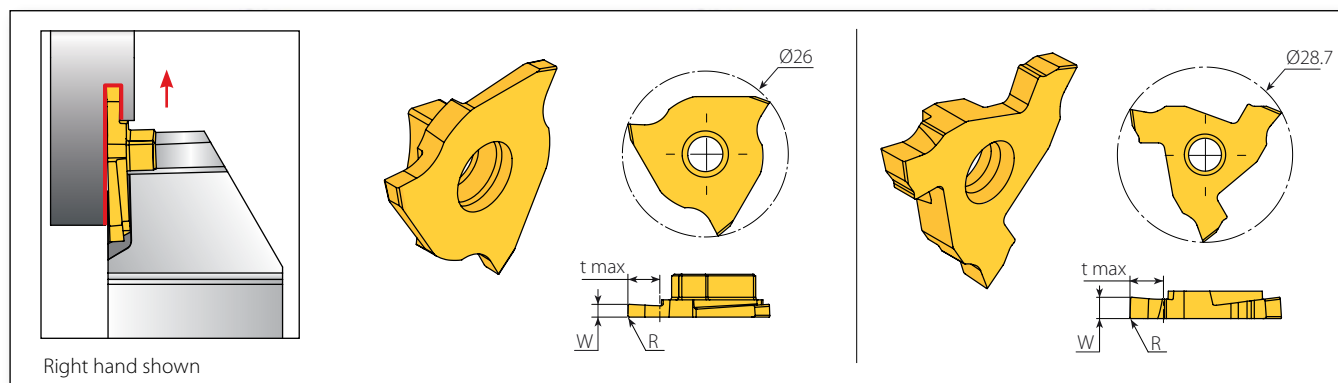

Right hand shown

Insert Size	Ordering Code	Dimensions mm			Grade		Toolholder
		W ± 0.02	R ± 0.03	t max	VKX	VTX	
IC	RH/LH						
	GVN26R/LS0.5-0.12	0.50	0.12	1.0	○	●	
	GVN26R/LS0.57-00	0.57	0.00	1.0	●	●	
	GVN26R/LS0.77-00	0.77	0.00	1.6	○	●	
	GVN26R/LS0.79-00	0.79	0.00	1.6	●	○	
	GVN26R/LS0.79-0.2	0.79	0.20	1.6	●	●	
	GVN26RS0.8-0.2	0.80	0.20	2.0	●	○	
	GVN26R/LS0.87-00	0.87	0.00	2.0	●	○	
	GVN26R/LS0.97-00	0.97	0.00	2.0	●	○	
	GVN26RS1.0-0.1	1.00	0.10	2.0	●	●	
	GVN26LS1.0-0.1	1.00	0.10	2.0	●	○	
	GVN26R/LS1.07-00	1.07	0.00	2.0	●	○	
	GVN26R/LS1.2-00	1.20	0.00	2.0	●	○	
	GVN26R/LS1.24-00	1.24	0.00	2.0	●	○	
	GVN26R/LS1.4-00	1.40	0.00	2.0	●	○	
	GVN26R/LS1.44-00	1.44	0.00	2.0	●	●	
	GVN26RS1.5-0.1	1.50	0.10	3.0	●	●	
	GVN26LS1.5-0.1	1.50	0.10	3.0	●	○	
	GVN26R/LS1.5-0.2	1.50	0.20	5.0	●	○	
	GVN26R/LS1.58-0.2	1.58	0.20	3.0	●	○	
26	GVN26R/LS1.6-00	1.60	0.00	3.0	●	○	GVNE...-26, GVNE90...-26
	GVN26RS1.6-0.4	1.60	0.40	3.5	○	●	
	GVN26R/LS1.7-0.1	1.70	0.10	3.0	●	○	
	GVN26R/LS1.74-00	1.74	0.00	3.0	●	○	
	GVN26RS1.8-0.15	1.80	0.15	4.5	○	●	
	GVN26RS1.8-0.4	1.80	0.40	4.5	○	●	
	GVN26RS1.9-0.4	1.90	0.40	4.5	○	●	
	GVN26R/LS2.0-00	2.00	0.00	3.0	●	○	
	GVN26R/LS2.0-0.1	2.00	0.10	3.0	●	○	
	GVN26RS2.0-0.15	2.00	0.15	4.5	○	●	
	GVN26RS2.0-0.2	2.00	0.20	5.0	●	●	
	GVN26LS2.0-0.2	2.00	0.20	5.0	●	○	
	GVN26RS2.0-0.4	2.00	0.40	4.5	○	●	
	GVN26R/LS2.22-0.15	2.22	0.15	5.0	●	○	
	GVN26RS2.25-0.4	2.25	0.40	4.5	○	●	
	GVN26RS2.25-0.8	2.25	0.80	5.0	○	●	
	GVN26R/LS2.39-0.15	2.39	0.15	5.0	●	○	
	GVN26RS2.4-0.15	2.40	0.15	4.5	○	●	
	GVN26LS2.45-0.3	2.45	0.30	4.5	○	●	
	GVN26R/LS2.47-0.2	2.47	0.20	5.0	●	○	

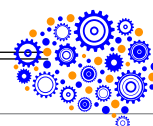

Close to Shoulder Square Grooving (con't)

Insert Size	Ordering Code	Dimensions mm			Grade		Toolholder
IC	RH/LH	W ^{±0.02}	R ^{±0.03}	t max	VKX	VTX	
29	GVN29R/LS2.38-0.1	2.38	0.10	6.5	•	○	GVNE...-29-1, GVNE90...-29-1, GVNI...-29
	GVN29R/LS2.5-0.1	2.50	0.10	6.5	•	○	
	GVN29RS2.5-0.2	2.50	0.20	6.5	○	•	
	GVN29R/LS2.7-0.1	2.70	0.10	6.5	•	○	
	GVN29R/LS3.0-0.2	3.00	0.20	6.5	•	○	
	GVN29R/LS3.17-0.2	3.17	0.20	6.5	•	○	
	GVN29R/LS3.5-0.2	3.50	0.20	6.5	•	•	GVNE...-29-2, GVNE90...-29-2, GVNI...-29
	GVN29R/LS4.0-0.4	4.00	0.40	6.5	•	•	
	GVN29RS4.15-0.6	4.15	0.60	6.5	○	•	
GVN29R/LS5.0-0.4	5.00	0.40	6.5	•	•		

• In stock ○ Available upon request

Close to Shoulder Round Grooving

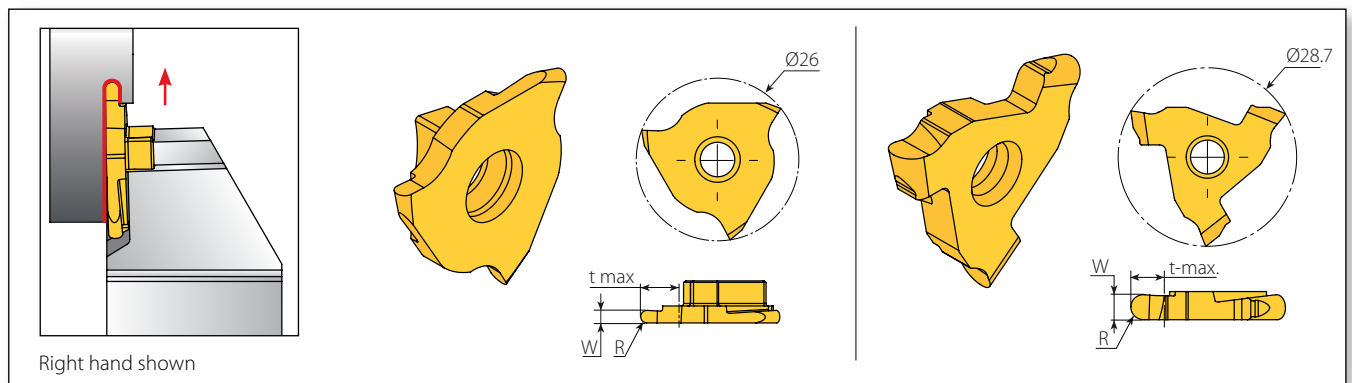

Insert Size	Ordering Code	Dimensions mm			Grade		Toolholder
IC	RH/LH	W ^{±0.02}	R ^{±0.03}	t max	VKX	VTX	
26	GVN26R/LR0.5-0.25	0.50	0.25	1.0	•	○	GVNE...-26, GVNE90...-26
	GVN26R/LR0.79-0.39	0.79	0.39	1.6	•	○	
	GVN26R/LR1.0-0.5	1.00	0.50	2.0	•	○	
	GVN26RR1.2-0.6	1.20	0.60	2.0	•	•	
	GVN26LR1.2-0.6	1.20	0.60	2.0	•	○	
	GVN26RR1.5-0.75	1.50	0.75	5.0	•	•	
	GVN26LR1.5-0.75	1.50	0.75	5.0	•	○	
	GVN26R/LR1.6-0.8	1.60	0.80	3.0	•	○	
	GVN26R/LR2.0-1.0	2.00	1.00	3.0	•	○	
	GVN26RR2.39-1.19	2.39	1.19	5.0	•	•	
GVN26LR2.39-1.19	2.39	1.19	5.0	•	○	GVNE...-29-1, GVNE90...-29-1, GVNI...-29	
GVN29RR1.5-0.75	1.50	0.75	6.5	○	•		
GVN29RR2.0-1.0	2.00	2.00	6.0	○	•		
GVN29R/LR2.38-1.19	2.38	1.19	6.5	•	○		
GVN29R/LR2.5-1.25	2.50	1.25	6.5	•	○		
GVN29R/LR3.0-1.5	3.00	1.50	6.5	•	○		
GVN29R/LR3.17-1.59	3.17	1.59	6.5	•	○		GVNE...-29-2, GVNE90...-29-2, GVNI...-29
GVN29R/LR4.0-2.0	4.00	2.00	6.5	•	•		

• In stock ○ Available upon request

Close to Shoulder Parting Off

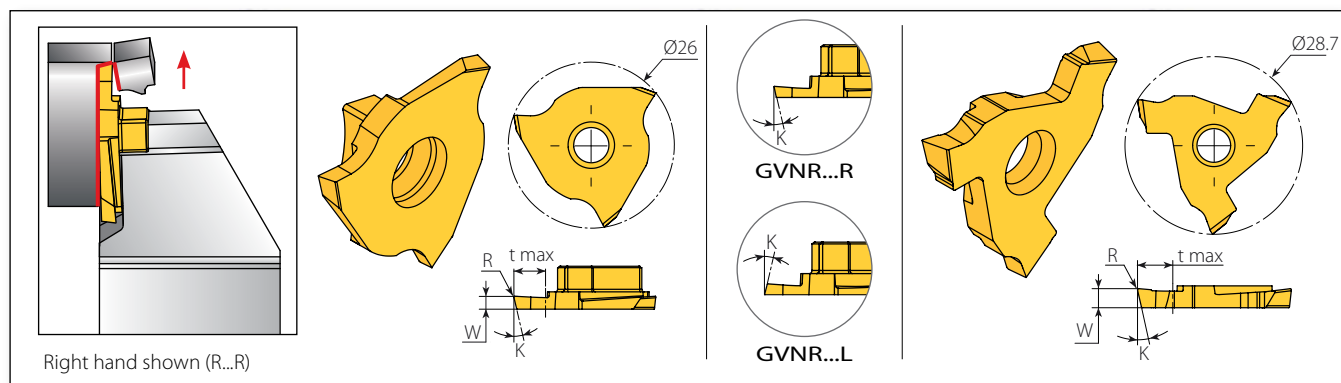

Insert Size	Ordering Code	Dimensions mm				Grade		Toolholder
		W ± 0.02	R ± 0.03	t max	K $^\circ$	VKX	VTX	
26	GVN26RP0.5-0.05-06R	0.5	0.05	1.0	6	•	◦	GVNE...-26, GVNE90...-26
	GVN26RP0.5-0.05-06L	0.5	0.05	1.0	6	•	◦	
	GVN26LP0.5-0.05-06R	0.5	0.05	1.0	6	•	◦	
	GVN26LP0.5-0.05-06L	0.5	0.05	1.0	6	•	◦	
	GVN26RP0.5-0.05-15R	0.5	0.05	1.0	15	•	◦	
	GVN26RP0.5-0.05-15L	0.5	0.05	1.0	15	•	◦	
	GVN26LP0.5-0.05-15R	0.5	0.05	1.0	15	•	◦	
	GVN26LP0.5-0.05-15L	0.5	0.05	1.0	15	•	◦	
	GVN26RP0.8-0.05-06R	0.8	0.05	4.0	6	◦	•	
	GVN26RP1.0-0.05-15R	1.0	0.05	3.5	15	◦	•	
	GVN26R/LP1.2-0.08-05R	1.2	0.08	1.0	5	•	◦	
	GVN26LP1.4-0.00-15R	1.4	0.00	5.0	15	◦	•	
	GVN26RP1.4-0.05-06R	1.4	0.05	5.0	6	•	◦	
	GVN26RP1.4-0.05-06L	1.4	0.05	5.0	6	•	◦	
	GVN26LP1.4-0.05-06R	1.4	0.05	5.0	6	•	◦	
	GVN26LP1.4-0.05-06L	1.4	0.05	5.0	6	•	◦	
	GVN26RP1.4-0.05-15R	1.4	0.05	5.0	15	•	◦	
	GVN26RP1.4-0.05-15L	1.4	0.05	5.0	15	•	◦	
	GVN26LP1.4-0.05-15R	1.4	0.05	5.0	15	•	◦	
	GVN26LP1.4-0.05-15L	1.4	0.05	5.0	15	•	◦	
	GVN26RP1.4-0.2-06R	1.4	0.20	5.0	6	◦	•	
	GVN26RP2.0-0.1-06R	2.0	0.10	5.0	6	•	•	
	GVN26RP2.0-0.1-06L	2.0	0.10	5.0	6	•	◦	
	GVN26LP2.0-0.1-06R	2.0	0.10	5.0	6	•	◦	
	GVN26LP2.0-0.1-06L	2.0	0.10	5.0	6	•	◦	
	GVN26RP2.0-0.1-10R	2.0	0.10	6.2	10	◦	•	
GVN26RP2.0-0.1-15R	2.0	0.10	5.0	15	•	◦		
GVN26RP2.0-0.1-15L	2.0	0.10	5.0	15	•	◦		
GVN26LP2.0-0.1-15R	2.0	0.10	5.0	15	•	◦		
GVN26LP2.0-0.1-15L	2.0	0.10	5.0	15	•	◦		
29	GVN29RP2.5-0.2-06R	2.5	0.20	6.5	6	•	•	GVNE...-29-1, GVNE90...-29-1, GVNI...-29
	GVN29RP2.5-0.2-06L	2.5	0.20	6.5	6	◦	◦	
	GVN29LP2.5-0.2-06R	2.5	0.20	6.5	6	◦	◦	
	GVN29LP2.5-0.2-06L	2.5	0.20	6.5	6	•	•	
	GVN29RP2.5-0.2-15R	2.5	0.20	6.5	15	•	•	
	GVN29RP2.5-0.2-15L	2.5	0.20	6.5	15	◦	◦	
	GVN29LP2.5-0.2-15R	2.5	0.20	6.5	15	◦	◦	
	GVN29LP2.5-0.2-15L	2.5	0.20	6.5	15	•	•	
	GVN29RP3.0-0.2-06R	3.0	0.20	6.5	6	•	•	
	GVN29RP3.0-0.2-06L	3.0	0.20	6.5	6	◦	◦	
	GVN29LP3.0-0.2-06R	3.0	0.20	6.5	6	◦	◦	
	GVN29LP3.0-0.2-06L	3.0	0.20	6.5	6	•	•	
	GVN29RP3.0-0.2-15R	3.0	0.20	6.5	15	•	•	
	GVN29RP3.0-0.2-15L	3.0	0.20	6.5	15	◦	◦	
GVN29LP3.0-0.2-15R	3.0	0.20	6.5	15	◦	◦		
GVN29LP3.0-0.2-15L	3.0	0.20	6.5	15	•	•		

• In stock ◦ Available upon request



Square Grooving (GV29)

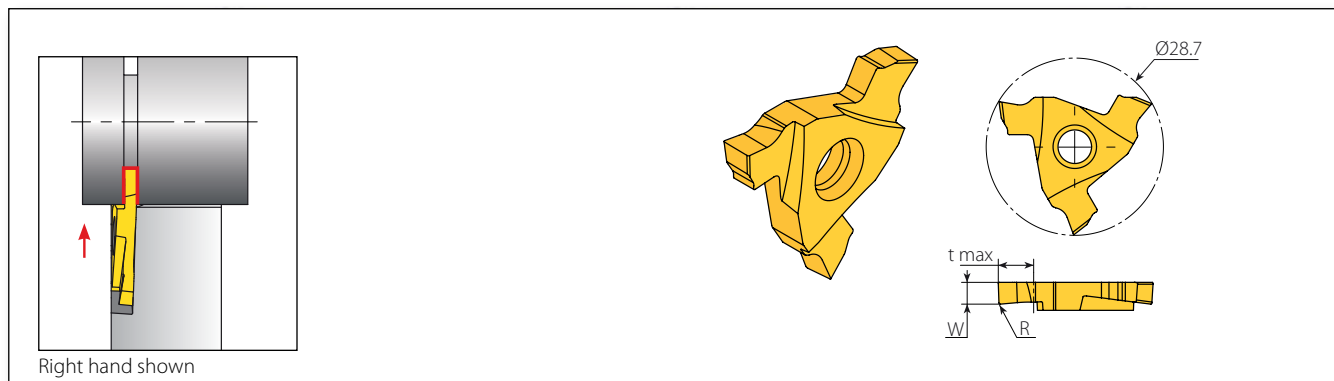

Insert Size	Ordering Code	Dimensions mm			Grade		Toolholder
IC	RH/LH	W ± 0.02	R ± 0.03	t max	VKX	VTX	
29	GV29R/LS2.38-0.1	2.38	0.10	6.5	•	•	GVE...-29-1, GVE90...-2901, GVI...-29
	GV29R/LS2.5-0.1	2.50	0.10	6.5	•	•	
	GV29R/LS2.7-0.1	2.70	0.10	6.5	•	•	
	GV29R/LS3.0-0.2	3.00	0.20	6.5	•	•	
	GV29RS3.0-0.4	3.00	0.40	6.5	•	•	GVE...-29-2, GVE90...-29-2, GVI...-29, GVNE...-29-2, GVNE90...-29-2, GVNI...-29
	GV29R/LS3.17-0.2	3.17	0.20	6.5	•	•	
	GV29R/LS3.5-0.2	3.50	0.20	6.5	•	•	
	GV29R/LS4.0-0.4	4.00	0.40	6.5	•	•	
	GV29RS4.0-0.8	4.00	0.80	6.5	◦	•	
	GV29RS4.5-0.3	4.50	0.30	6.5	◦	•	
GV29R/LS5.0-0.4	5.00	0.40	6.5	•	•		

■ In stock ◦ Available upon request

Round Grooving (GV29)

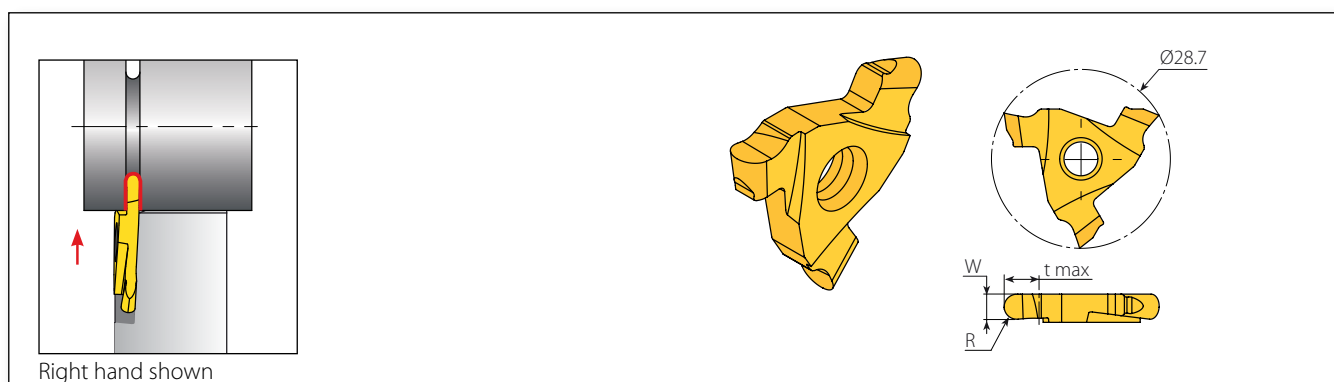

Insert Size	Ordering Code	Dimensions mm			Grade		Toolholder
IC	RH/LH	W ± 0.02	R ± 0.03	t max	VKX	VTX	
29	GV29R/LR2.38-1.19	2.38	1.19	6.5	•	•	GVE...-29-1, GVE90...-2901, GVI...-29
	GV29R/LR2.5-1.25	2.50	1.25	6.5	•	•	
	GV29R/LR3.0-1.5	3.00	1.50	6.5	•	•	
	GV29R/LR3.17-1.59	3.17	1.59	6.5	•	•	GVE...-29-2, GVE90...-29-2, GVI...-29, GVNE...-29-2, GVNE90...-29-2, GVNI...-29
	GV29R/LR4.0-2.0	4.00	2.00	6.5	•	•	

■ In stock ◦ Available upon request

Groovical Holders

Close to Shoulder External Toolholders.....	75
Close to Shoulder External Toolholders 90°.....	76
Modules with HPC.....	77
Modular Bodies with HPC.....	78
Modular V-CAP Holders with HPC.....	79
External Toolholders (GV29).....	80
External Toolholders 90° (GV29).....	80



Groovical Holders - Ordering Code System

Square Shank Tools

GVN	E	R	20	-	29	-	1
1	2	3	4		5		7

Modules

GVN	A	R	29	-	T6.5	-
1	2	3	5		6	

1 - Insert Type GVN - Groovical Close to Shoulder GV - Groovical Neutral	2 - External Type E - External E90 - External 90° A - Module	3 - RH or LH R - RH L - LH	4 - Shank Size 10, 12, 16, 20, 25, 32, 40 mm
---	--	---	--

5 - Insert Size 26 29	6 - t max (for Modules Only) T5.5 - 5.5mm T6.5 - 6.5mm	7 - Insert Width (for GVN29 & GV29) 1 - 2.5 - 3.5mm 2 - 3.6 - 5.5mm	8 - Coolant C - Coolant (for Modular system)
------------------------------------	---	--	--

Square Bodies

VBM	R	2525	-	90	-	C
1	2	3		4		5

V-CAP Bodies

VBM	R	C5	-	90	-	C
1	2	3		4		5

1 - Body Type VBM - Square body VBC - V-CAP body	2 - RH or LH R - RH L - LH None - Neutral	3 - Shank Width 2525 - Square body dimensions C5 - V-CAP polygon shape	4 - Approach Angle 0 - Parallel 0° 90 - 90°	5 - Coolant C - Coolant
---	---	---	--	-----------------------------------



Close to Shoulder External Tools

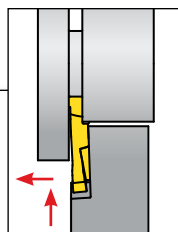

Right hand shown

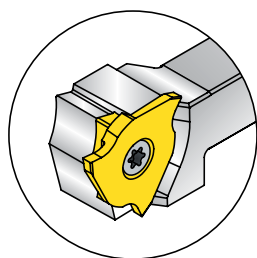

GVN26

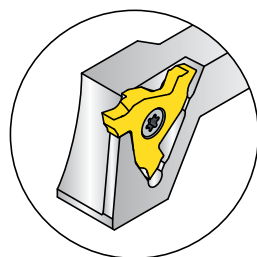

GVN29

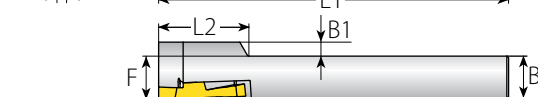
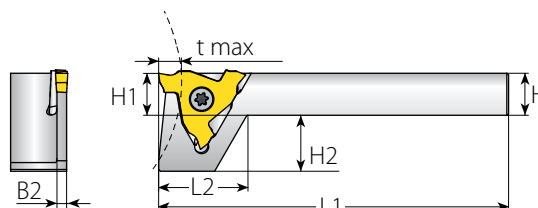
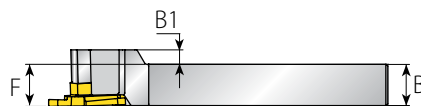
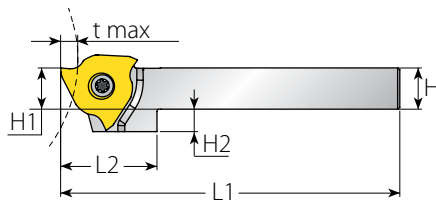

Spare Parts

Insert Size	Ordering Code	Dimensions mm									Insert Screw*	Torx Key		
		RH/LH	H=B	L1	H1	L2	H2	F	B1	B2			t max/D max	
26	GVNER/L10-26		10	125	10	28.0	8.5	10.2	6.2			See page 66	SGM5	L20IP
	GVNER/L12-26		12	125	12	28.0	6.5	12.2	4.2					
	GVNER/L16-26		16	125	16	28.0	2.5	16.2	-	-				
	GVNER/L20-26		20	125	20	28.0	-	20.2	-	-				
	GVNER/L25-26		25	150	25	28.0	-	25.2	-	-				
29	GVNER/L12-29-1		12	100	12	25.5	16	12.5	4	1.75				
	GVNER/L12-29-2		12	100	12	25.5	16	12.5	4	2.75				
	GVNER/L16-29-1		16	125	16	23.2	12	16.5	-	1.75				
	GVNER/L16-29-2		16	125	16	23.2	12	16.5	-	2.75				
	GVNER/L20-29-1		20	125	20	20.9	8	20.5	-	1.75				
	GVNER/L20-29-2		20	125	20	20.9	8	20.5	-	2.75				
	GVNER/L25-29-1		25	150	25	18.0	3	25.5	-	1.75				
	GVNER/L25-29-2		25	150	25	18.0	3	25.5	-	2.75				

* Tightening Torque 4.5 Nm

Close to Shoulder External Tools 90°

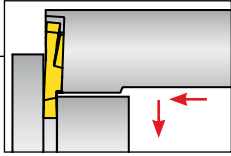

Right hand shown

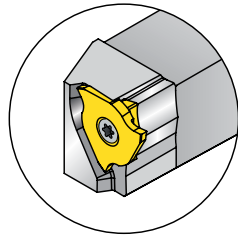

GVN26

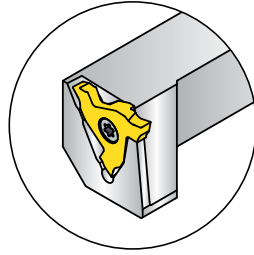
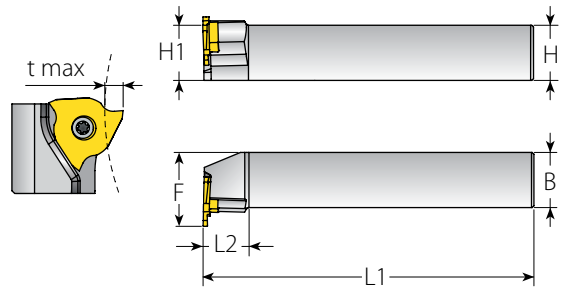

GVN29

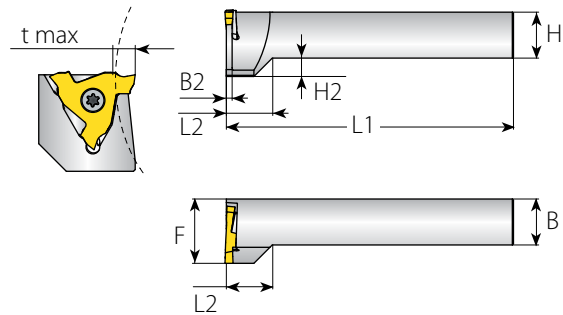

Spare Parts

Insert Size	Ordering Code	Dimensions mm								Insert Screw*	Torx Key	
		RH/LH	H=B	L1	H1	L2	B2	H2	F			t max/D max
26	GVNE90R/L20-26		20	125	20	20.0	-	-	28.5	See page 66	SGM5	L20IP
	GVNE90R/L25-26		25	150	25	20.0	-	-	33.5			
29	GVNE90R/L20-29-1		20	125	20	20.2	1.75	8	28.0			
	GVNE90R/L20-29-2		20	125	20	20.2	2.75	8	28.0			
	GVNE90R/L25-29-1		25	150	25	25.0	1.75	3	33.0			
	GVNE90R/L25-29-2		25	150	25	25.0	2.75	3	33.0			

* Tightening Torque 4.5 Nm

For **LH90°** work applications use **LH toolholder** with **RH insert** and vice versa.

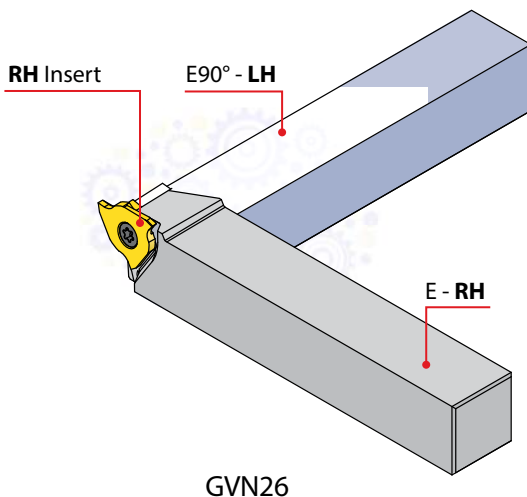

GVN26

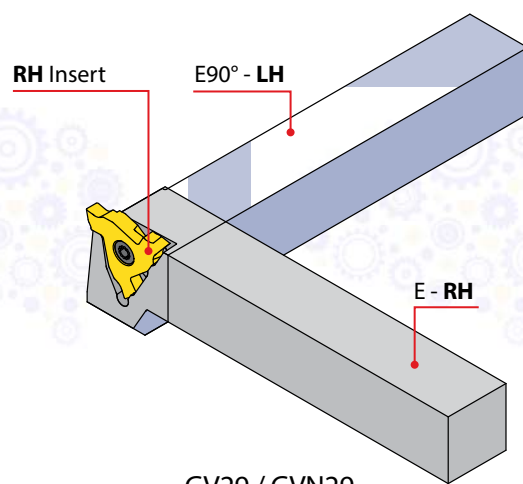

GVN29 / GVN29



Modular System with High Pressure Coolant (HPC)

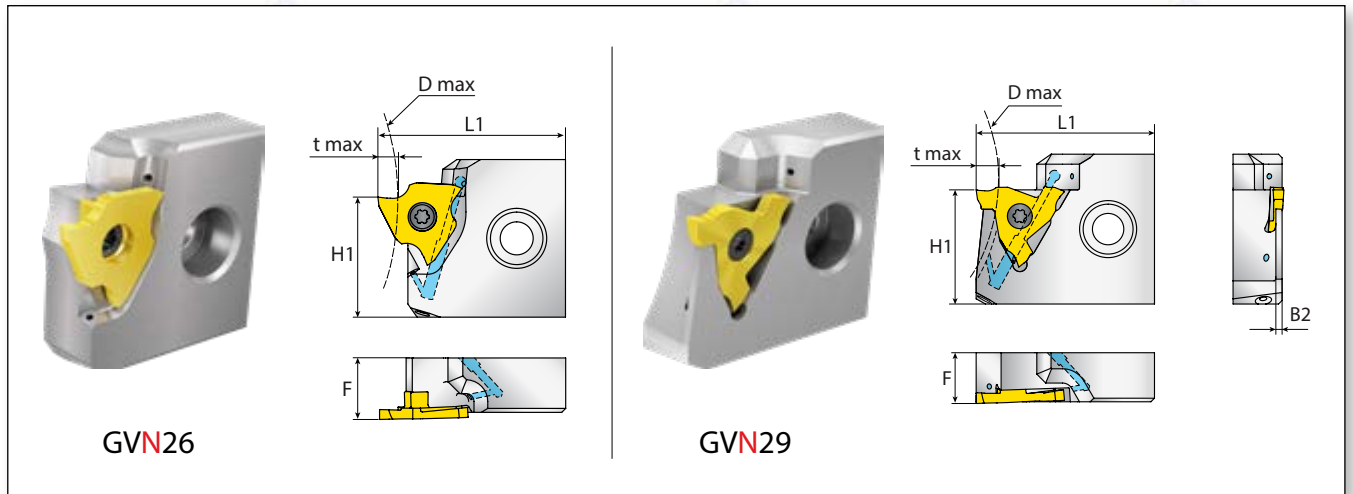
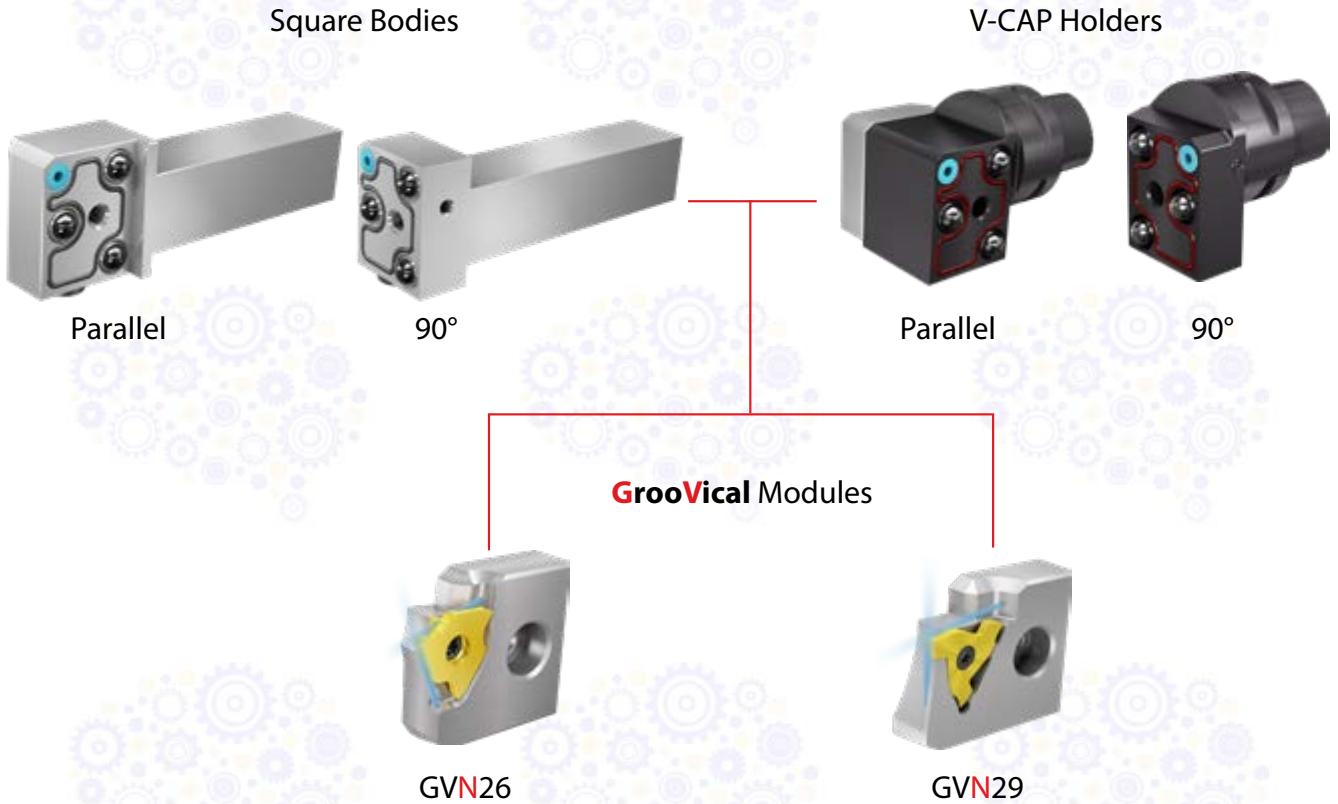

Modules with High Pressure Coolant

Insert Size	Ordering Code	Dimensions mm						Spare Parts		
		RH/LH	L1	H1	F	B2	t max	D max	Insert Screw*	Torx Key
26	GVNAR/L26-T5.5C		50	32	15.55	-	5.5	See page 66	SGM5	L20IP
29	GVNAR/L29-T6.5-1C GVNAR/L29-T6.5-2C		50	32	14.25	1.75 2.75	6.5 6.5			

* Tightening Torque: 4.5 Nm max.

ТОВ «СМАРТТЕК ІНЖИНІРИНГ», Т. +380-50-396-90-96, info@smarttec.com.ua, https://www.smarttec.com.ua

Modular Bodies with High Pressure Coolant

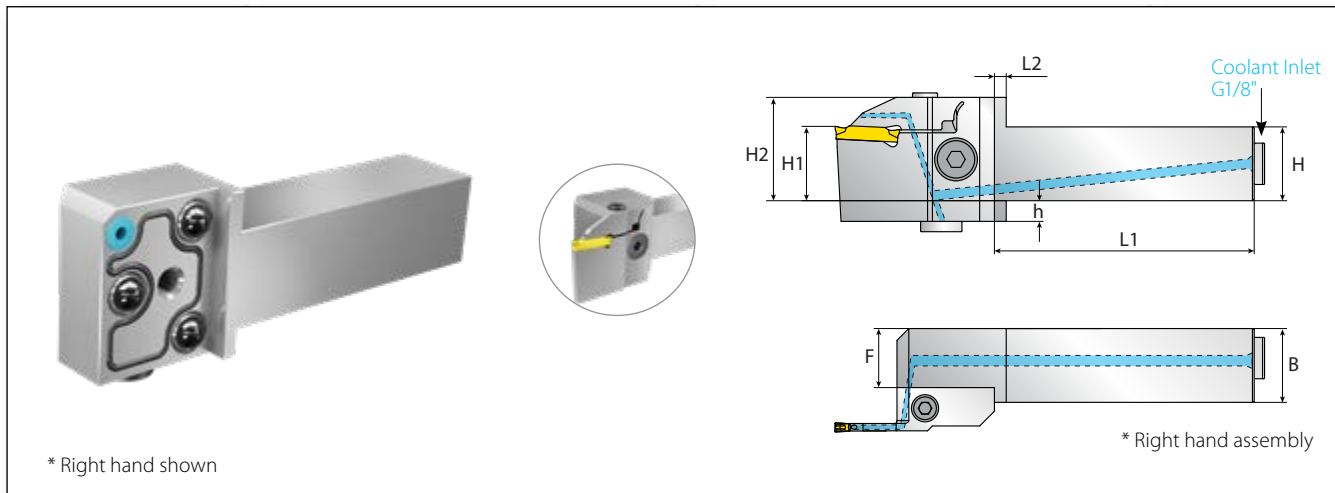

Parallel Square Bodies with HPC

Ordering Code		Dimensions mm							Spare Parts				
RH/LH	H/H1	B	H2	h	F	L1	L2	Clamping Screw*	Key	Plug Screw	Coolant Seal	Anti Vibration O-Ring	
VBMR/L2020-00-C	20	20	30	12	15	106	4	SM8x25	K6H	Plug G1/8"	Coolant Sleeve	O-RING Body Seal	
VBMR/L2525-00-C	25	25	35	7	20	121	4						
VBMR/L3225-00-C	32	25	42	0	20	136	4						

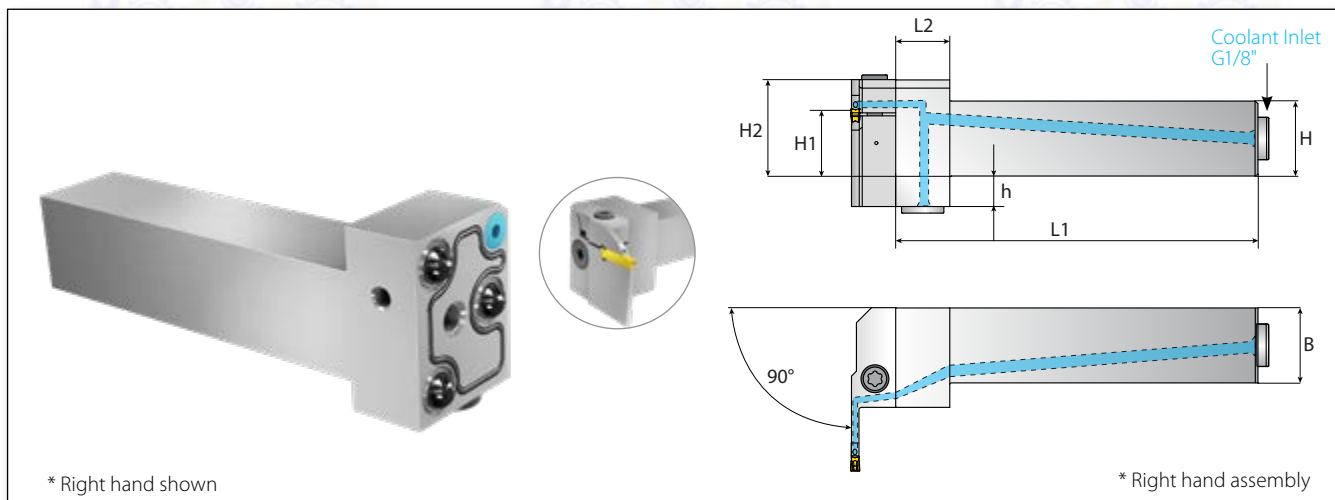

90° Square Bodies with HPC

Ordering Code		Dimensions mm							Spare Parts				
RH/LH	H/H1	B	H2	h	L1	L2	Clamping Screw*	Key	Plug Screw	Coolant Seal	Anti Vibration O-Ring		
VBMR/L2020-90-C	20	20	30	12	111	18	SM8x25	K6H	Plug G1/8"	Coolant Sleeve	O-RING Body Seal		
VBMR/L2525-90-C	25	25	35	7	120	18							
VBMR/L3232-90-C	32	32	42	0	130	18							

* Tightening Torque: 26 NM max.

Necessary Parts When Using Modules with High Pressure Coolant Thru:

1. Tube Connector 25-6P (x1)
2. Fittings (x2): Straight Fitting G1_8x6P or Angled Fitting G1_8x6P

The above items are not included and should be ordered separately. For more information please see page 21.







Modular V-CAP Holders with HPC



Parallel V-CAP Bodies with HPC

Spare Parts

Ordering Code	Dimensions mm										
RH+LH	D	L	L1	L2	F	H1	Clamping Screw* (x2)	Key	Modular Cover	Coolant Seal	Anti Vibration O-Ring
VBC C4-00-C	40	78	54	21	17	32	SM8x18	K6H	VG-MC	Coolant Sleeve	O-RING Body Seal
VBC C5-00-C	50	88	58	21	18.5						
VBC C6-00-C	63	98	60	23	24.5						

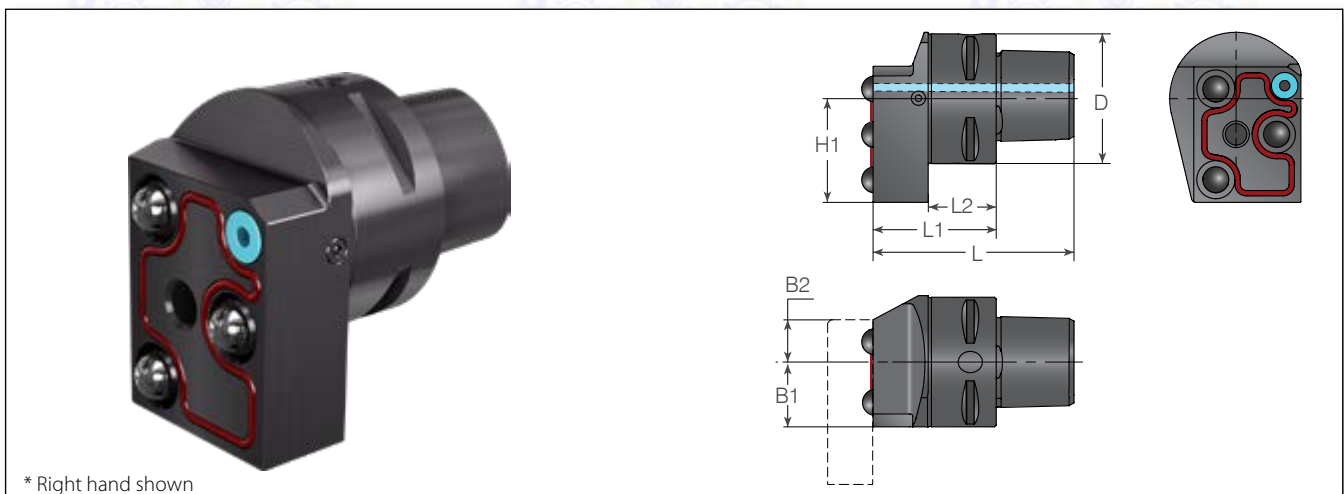

90° V-CAP Bodies with HPC

Spare Parts

Ordering Code	Dimensions mm										
RH/LH	D	L	L1	L2	B1	B2	H1	Clamping Screw*	Key	Coolant Seal	Anti Vibration O-Ring
VBCR/L C4-90-C	40	64	40	21	20	13.0	32	SM8x18	K6H	Coolant Sleeve	O-RING Body Seal
VBCR/L C5-90-C	50	70	40	21	26.5	6.75					
VBCR/L C6-90-C	63	78	40	23	32.7	0.5					

V-CAP holders are according to ISO 26623.

* Tightening Torque: 26 Nm max.

External Tools (GV29)

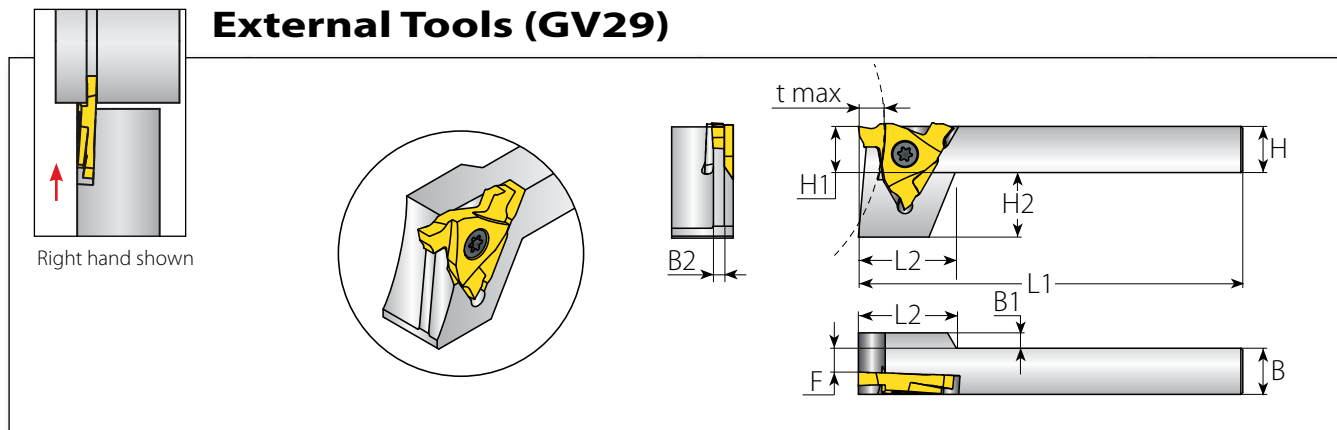

Insert Size	Ordering Code	Dimensions mm									Spare Parts		
		RH/LH	H=B	L1	H1	L2	H2	F	B1	B2	t max/D max	Insert Screw*	Torx Key
29	GVER/L12-29-1		12	100	12	25.5	16	7.2	4	1.75	See page 66	SGM5	L20IP
	GVER/L12-29-2		12	100	12	25.5	16	6.2	4	2.75			
	GVER/L16-29-1		16	125	16	23.2	12	11.2	-	1.75			
	GVER/L16-29-2		16	125	16	23.2	12	10.2	-	2.75			
	GVER/L20-29-1		20	125	20	20.9	8	15.2	-	1.75			
	GVER/L20-29-2		20	125	20	20.9	8	14.2	-	2.75			
	GVER/L25-29-1		25	150	25	18	3	20.2	-	1.75			
	GVER/L25-29-2		25	150	25	18	3	19.2	-	2.75			

* Tightening Torque 4.5 Nm

External Toolholders 90° (GV29)

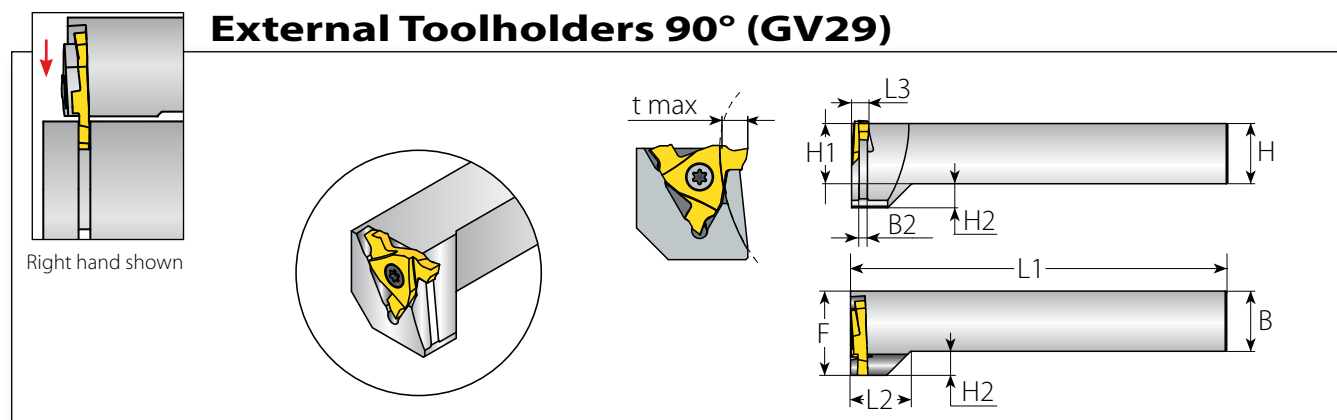

Insert Size	Ordering Code	Dimensions mm									Spare Parts		
		RH/LH	H=B	L1	H1	L2	H2	F	L3	B2	t max/D max	Insert Screw*	Torx Key
29	GVE90R/L20-29-1		20	125	20	20.2	8	28	4.8	1.75	See page 66	SGM5	L20IP
	GVE90R/L20-29-2		20	125	20	20.2	8	28	5.8	2.75			
	GVE90R/L25-29-1		25	150	25	25.2	8	33	4.8	1.75			
	GVE90R/L25-29-2		25	150	25	25.2	8	33	5.8	2.75			

* Tightening Torque 4.5 Nm



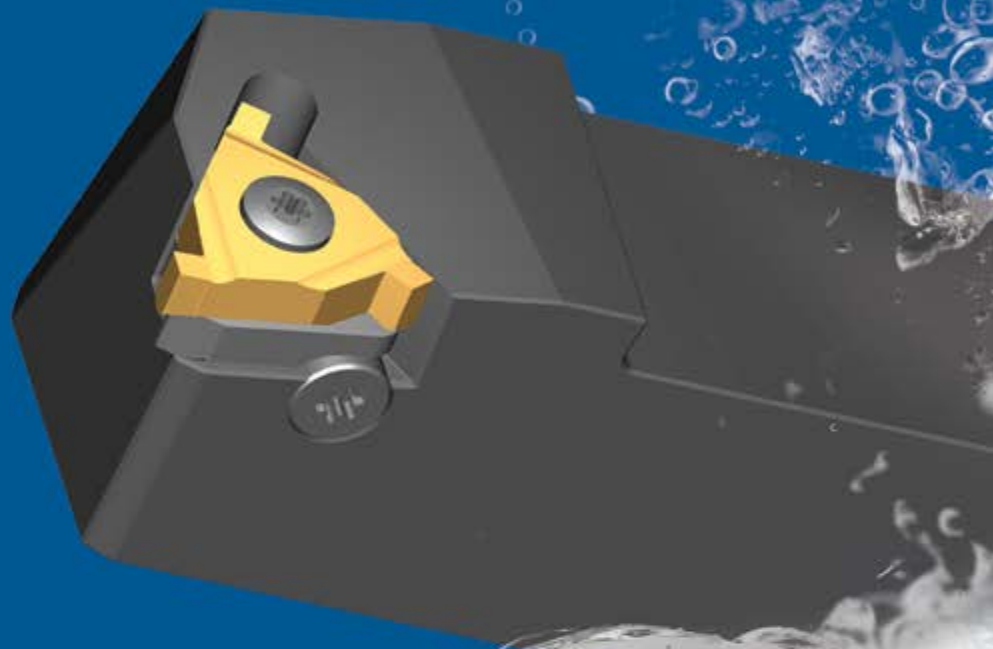

EXTERNAL GROOVE TURNING | FINISHING

Laydown Grooving

For Shallow Grooves





Technical Data

Recommended Grades, Cutting Speeds Vc [m/min] and Feed f [mm/rev]

Material Group	Vargus No.	Material	Hardness Brinell HB	Vc [m/min]		Feed [mm/rev]	
				Coated			
				VTX	VKX		
P Steel	1	Unalloyed steel	Low carbon (C=0.1-0.25%)	125	140-200	140-200	0.3
	2		Medium carbon (C=0.25-0.55%)	150	120-180	120-180	0.15
	3		High Carbon (C=0.55-0.85%)	170	110-180	110-180	0.05
	4	Low alloy steel (alloying elements ≤ 5%)	Non hardened	180	100-155	100-155	0.25
	5		Hardened	275	90-145	90-145	0.1
	6		Hardened	350	80-135	80-135	0.05
	7	High alloy steel (alloying elements >5%)	Annealed	200	70-115	65-115	0.2
	8		Hardened	325	50-100	50-100	0.05
	9	Cast steel	Low alloy (alloying elements <5%)	200	30-50	30-50	0.2
	10		High alloy (alloying elements >5%)	225	20-40	25-40	0.05
M Stainless Steel	11	Stainless steel Ferritic	Non hardened	200	70-120	80-120	0.2
	12		Hardened	330	60-95	55-95	0.05
	13	Stainless steel Austenitic	Austenitic	180	70-100	60-100	0.2
	14		Super Austenitic	200	40-90	50-90	0.05
	15	Stainless steel Cast Ferritic	Non hardened	200	80-110	60-80	0.2
	16		Hardened	330	65-110	45-65	0.05
	17	Cast austenitic	Austenitic	200	85-100	50-70	0.2
	18		Hardened	330	60-100	40-60	0.05
K Cast Iron	28	Malleable Cast iron	Ferritic (short chips)	130	70-120	60-80	0.2
	29		Pearlitic (long chips)	230	70-120	60-80	0.15
	30	Grey cast iron	Low tensile strength	180	70-120	60-80	0.2
	31		High tensile strength	260	60-100	40-70	0.1
	32	Nodular SG iron	Ferritic	160	50-80	60-80	0.2
	33		Pearlitic	260	60-90	70-90	0.1
N_(K) Non-Ferrous Metals	34	Aluminum alloys Wrought	Non aging	60	100-240	80-240	0.4
	35		Aged	100	80-170	100-170	0.1
	36	Aluminum alloys	Cast	75	100-150	100-150	0.25
	37		Cast & aged	90	80-120	60-100	0.15
	38	Aluminum alloys	Cast Si 13-22%	130	100-150	100-150	0.15
	39	Copper and copper alloys	Brass	90	80-200	80-200	0.2
40	Bronze and non leaded copper		100	80-200	80-200	0.15	
S_(M) Heat Resistant Material	19	High temperature alloys	Annealed (Iron based)	200	45-60	25-45	0.2
	20		Aged (Iron based)	280	35-50	20-30	0.05
	21		Annealed (Nickel or Cobalt based)	250	20-30	15-20	0.05
	22		Aged (Nickel or Cobalt based)	350	15-25	10-15	0.05
	23	Titanium alloys	Pure 99.5 Ti	400Rm	140-170	60-100	0.1
	24		α+β alloys	1050Rm	50-70	40-50	0.05
H_(K) Hardned Material	25	Extra hard steel	Hardened & tempered	45-50HRc	45-60	20-40	0.02
	26			51-55HRc	40-50	20-35	0.02

Grades and Their Application

Grade	Application Type	Sample
VTX	General use carbide grade. A tough sub-micron substrate with TiAlN coating. Provides good fracture toughness and excellent wear resistance.	
VKX	Superior general purpose grade, excellent in steels and stainless steels, recommended for rigid cutting conditions TiN coated.	



Laydown Grooving Inserts

DIN 471 Retaining Ring Grooves for Shafts.....	84
DIN 7993 Snap Ring Grooves.....	85
CIRCLIP Inch Standard.....	85
DIN 76 Thread Undercuts.....	86

Laydown Grooving Inserts - Ordering Code System

3	E	R	1.1	C	D471	-	0.35	VTX
1	2	3	4	5	6		7	8

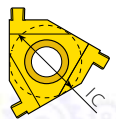
1 - Insert Size	
3 - IC3/8"	
5 - IC5/8"	

2 - Type of Insert
E - External

3 - RH / LH Insert
R - Right Hand Insert
L - Left Hand Insert

4 - Groove Std. Width
0.8 - 2.15 (mm)

5 - Profile Style
C - Full Profile

6 - Groove Standard
DIN 471 Partial
DIN 471
DIN 7993 Partial
DIN 7993
DIN 76 ST, DIN 76 SH
CIR - CIRCLIP

7 - Groove Depth
0.33 - 2.0 (mm)

8 - Carbide Grade
VTX
VKX



DIN 471 Retaining Ring Grooves for Shafts

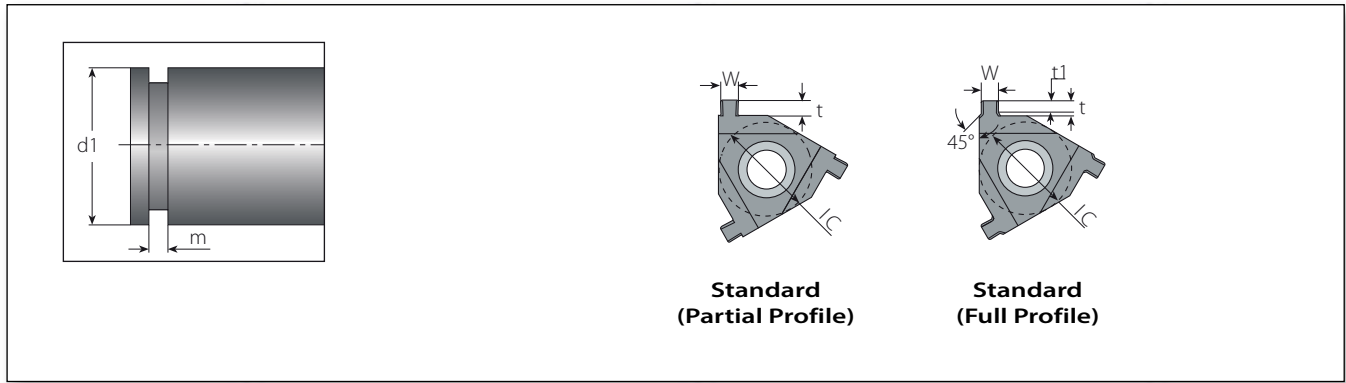

Standard (Partial Profile)

Insert Size	Ordering Code	Groove Std.	Dimensions mm			Grade		Anvil	Holder
			IC	RH	m (H13)	W	t		
3/8"	3ER1.1D471-1.3	1.10	1.19	1.3	•	•	YE3M-1.5N	AL...-3	
	3ER1.3D471-1.5	1.30	1.39	1.5	•	•			
	3ER1.6D471-1.85	1.60	1.69	1.8	•	•			
	3ER1.85D471-2.0	1.85	1.94	2.0	•	•			

Range of profiles also available on IC 1/4", 1/2" and 5/8", inserts on request.

█ • In stock ◦ Available upon request

Standard (Full Profile)

Insert Size	Ordering Code	Groove Std.	Dimensions mm				Grade		Anvil	Holder
			IC	RH	m(H13)	d1	W	t1		
3/8"	3ER1.1CD471-0.35	1.10	15	1.19	0.33	0.35	•	•	YE3M-1.5N	AL...-3
	3ER1.1CD471-0.4	1.10	16-17	1.19	0.36	0.40	•	•		
	3ER1.3CD471-0.5	1.30	18-22	1.39	0.44	0.50	•	•		
	3ER1.3CD471-0.55	1.30	24-26	1.39	0.45	0.55	•	•		
	3ER1.6CD471-0.7	1.60	28-30	1.69	0.60	0.70	•	•		
	3ER1.6D471-0.85	1.60	32-34	1.69	0.75	0.85	•	•		
	3ER1.6CD471-1.0	1.60	35	1.69	0.85	1.00	•	•		
	3ER1.85CD471-1.0	1.85	36-38	1.94	0.85	1.00	•	•		
	3ER1.85CD471-1.25	1.85	40-48	1.94	1.10	1.25	•	•		
	3ER2.15CD471-1.5	2.15	50-63	2.24	1.35	1.50	•	•		

Range of profiles also available on IC 1/4", 1/2" and 5/8", inserts on request.

█ • In stock ◦ Available upon request



DIN 7993 Snap Ring Grooves



Standard (Partial Profile for Shafts)

Insert Size	Ordering Code	Dimensions mm			Grade		Anvil	Holder	
		IC	RH	R	W	t			VKX
3/8"	3ER0.4D7993-0.6		0.40	0.80	0.60	•	•	YE3M-1.5N	AL..-3
	3ER0.6D7993-0.8		0.60	1.20	0.80	•	•		
	3ER0.9D7993-1.1		0.90	1.80	1.10	•	•		
	3ER1.0D7993-1.2		1.00	2.00	1.20	•	•		

Range of profiles also available on IC 1/4", 1/2" and 5/8", inserts on request.

• In stock • Available upon request

CIRCLIP Inch Standard



Standard (Partial Profile)

Insert Size	Ordering Code	Dimensions Inch		Grade		Anvil	Holder	
		IC	RH	W	t			VKX
3/8"	3ER.031CIRC-05		.031	.050	•	○	YE3M-1.5N	AL..-3
	3ER.041CIRC-07		.041	.070	•	○		
	3ER.047CIRC-07		.047	.080	•	○		
	3ER.058CIRC-08		.058	.080	•	○		
	3ER.062CIRC-08		.062	.080	•	○		
	3ER.072CIRC-08		.072	.080	•	○		
	3ER.078CIRC-08		.078	.080	•	○		

Range of profiles also available on IC 1/4", 1/2" and 5/8", inserts on request.

• In stock • Available upon request

ТОВ «СМАРТТЕК ІНЖИНІРИНГ», Т. +380-50-396-90-96, info@smarttec.com.ua, https://www.smarttec.com.ua

DIN 76 Thread Undercuts (For ISO Metric Threads in Accordance with DIN 13)

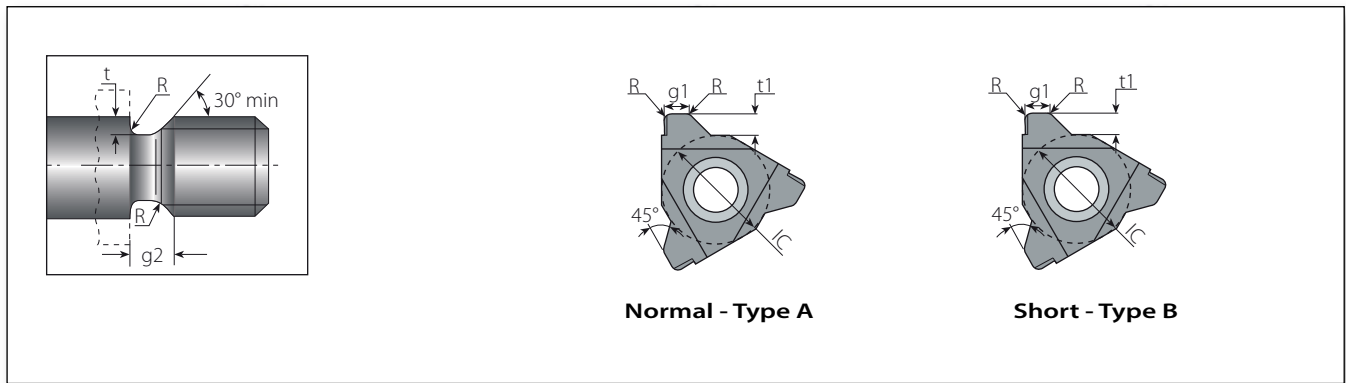

Standard (Normal - Type A)

Insert Size	Ordering Code	Pitch	Dimensions mm					Grade		Anvil	Holder
			IC	RH	mm	R	g1	g2	t		
3/8"	3ER0.50D76ST-0.40	0.50	0.2	1.10	1.50	0.40	2.50	•	○	YE3M-1.5N	AL...-3
	3ER0.60D76ST-0.50	0.60	0.4	1.30	1.80	0.50	2.40	•	○		
	3ER0.70D76ST-0.55	0.70	0.4	1.55	2.10	0.55	2.20	•	○		
	3ER0.80-D76ST-0.65	0.80	0.4	1.75	2.40	0.65	2.10	•	•		
5/8"	3ER1.00-D76ST-0.80	1.00	0.6	2.20	3.00	0.80	1.90	•	•	YE5M-1.5N	AL...-5
	5ER1.25D76ST-1.0	1.25	0.6	2.80	3.80	1.00	3.60	○	•		
	5ER1.50D76ST-1.15	1.50	0.8	3.35	4.50	1.15	3.30	•	•		
	5ER1.75D76ST-1.30	1.75	1.0	4.00	5.30	1.30	3.00	•	○		
	5ER2.0D76ST-1.50	2.00	1.0	4.50	6.00	1.50	2.70	•	○		

• In stock • Available upon request

Standard (Short - Type B)

Insert Size	Ordering Code	Pitch	Dimensions mm					Grade		Anvil	Holder
			IC	RH	mm	R	g1	g2	t		
3/8"	3ER1.00-D76SH-0.80	1.00	0.6	1.20	2.00	0.80	2.50	•	•	YE3M-1.5N	AL...-3
	3ER1.25-D76SH-1.00	1.25	0.6	1.50	2.50	1.00	2.30	•	•		
	3ER1.50-D76SH-1.15	1.50	0.8	1.85	3.00	1.15	2.10	•	•		
	3ER1.75-D76SH-1.30	1.75	1.0	2.20	3.50	1.30	1.90	•	•		
5/8"	5ER2.00D76SH-1.50	2.00	1.0	2.50	4.00	1.50	3.80	•	○	YE5M-1.5N	AL...-5
	5ER2.50D76SH-1.80	2.50	1.2	3.20	5.00	1.80	3.50	•	○		
	5ER3.00-D76SH-2.20	3.00	1.6	3.80	6.00	2.20	3.10	•	○		

Range of profiles also available on IC 1/4" and 1/2" inserts on request.

• In stock • Available upon request

Laydown Grooving Holders

External Standard Toolholders	88
External Standard Toolholders with Clamp	89

Laydown Grooving Holders - Ordering Code System

External Toolholders

A	L	32	-	4	
1	2	3		4	5
1 - Anvil	2 - Holder Style	3 - Shank Square [mm]	4 - Insert Size	5 - RH/LH Holder	
A - Anvil Required N - No Anvil Required	L - External	8, 10, 12, 16, 20, 25, 32, 40, 50, 60	3 - IC3/8" 5 - IC5/8"	None - Right Hand LH - Left Hand	





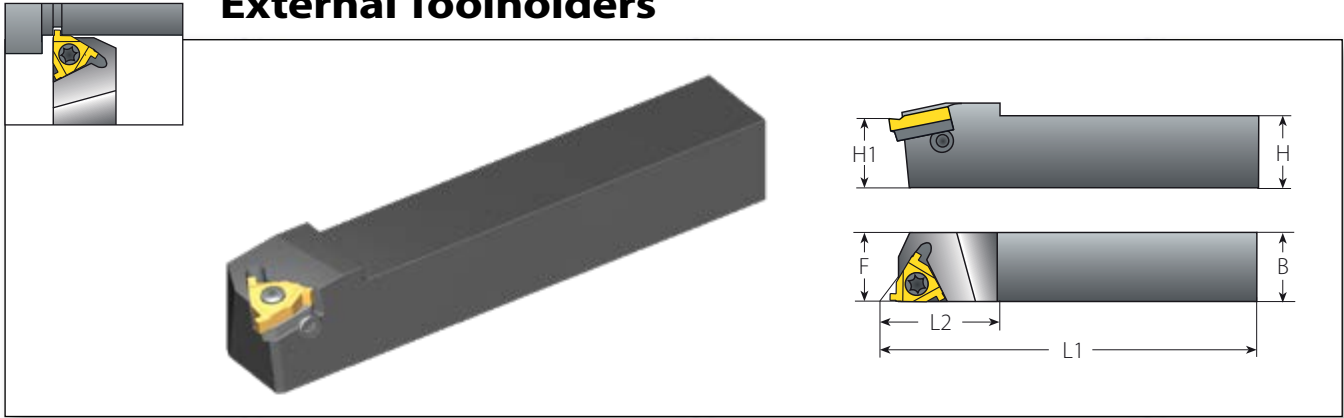

External Toolholders



Standard

Spare Parts

Insert Size	Ordering Code	Dimensions mm							 *
IC	RH	H=H1=B	F	L1	L2	Insert Screw	Anvil Screw	Torx Key	Anvil RH
1/4"	NL8-2	8	11	136.4	17.5	SN2T	-	K2T	-
	NL10-2	10	11	70.0	17.5				
	NL12-2	12	12	80.0	17.5				
3/8"	AL3/8-3	9.52	16	63.6	20.5	SA3T	SY3T	K3T	YE3M-1.5N
	AL12-3	12	16	100.0	22.0				
	AL16-3	16	16	82.3	20.5				
	AL20-3	20	20	128.6	30.0				
	AL25-3	25	25	153.6	30.0				
1/2"	AL25-4	25	25	155.7	36.0	SA4T	SY4T	K4T	YE4M-1.5N
	AL32-4	32	32	175.7	36.0				
	AL40-4	40	40	205.7	36.0				
5/8"	AL25-5	25	32	151.6	35.0	SA5T	SY5T	K5T	YE5M-1.5N
	AL32-5	32	32	176.6	40.0				
	AL40-5	40	40	206.6	40.0				
	AL50-5	50	50	256.6	40.0				

* The toolholders are supplied with standard anvils. For Grooving, please use the anvils indicated in the table above. For ordering code see page 83.

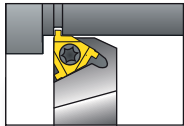

External Toolholders

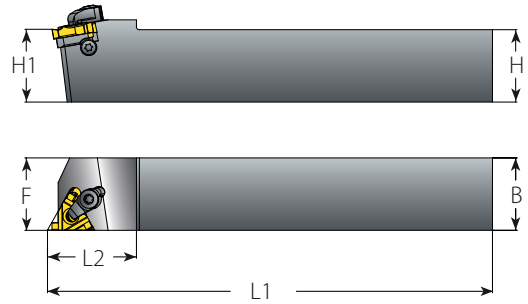

Standard with Clamp (Dual System, Screw or Clamp)

Spare Parts

Insert Size	Ordering Code	Dimensions mm								
		IC	RH/LH	H=H1=B	F	L1	L2	Insert Screw	Anvil Screw	Clamp
3/8"	AL16-3C	16	16	100.0	20.5	SA3T	SY3T	C3	K3CT	YE3M-1.5N
	AL20-3C	20	20	128.6	30					
	AL25-3C	25	25	153.6	30					
	AL32-3C	32	32	173.6	30					
1/2"	AL25-4C	25	25	155.7	36	SA4T	SY4T	C4	K4T	YE4M-1.5N
	AL32-4C	32	32	175.7	36					
	AL40-4C	40	40	205.7	36					
5/8"	AL25-5C	25	32	151.6	35	SA5T	SY5T	C5	K5T	YE5M-1.5N
	AL32-5C	32	32	176.6	40					
	AL40-5C	40	40	206.6	40					
	AL50-5C	50	50	256.6	40					

* The toolholders are supplied with standard anvils. For Grooving, please use the anvils indicated in the table above. For ordering code see page 83.



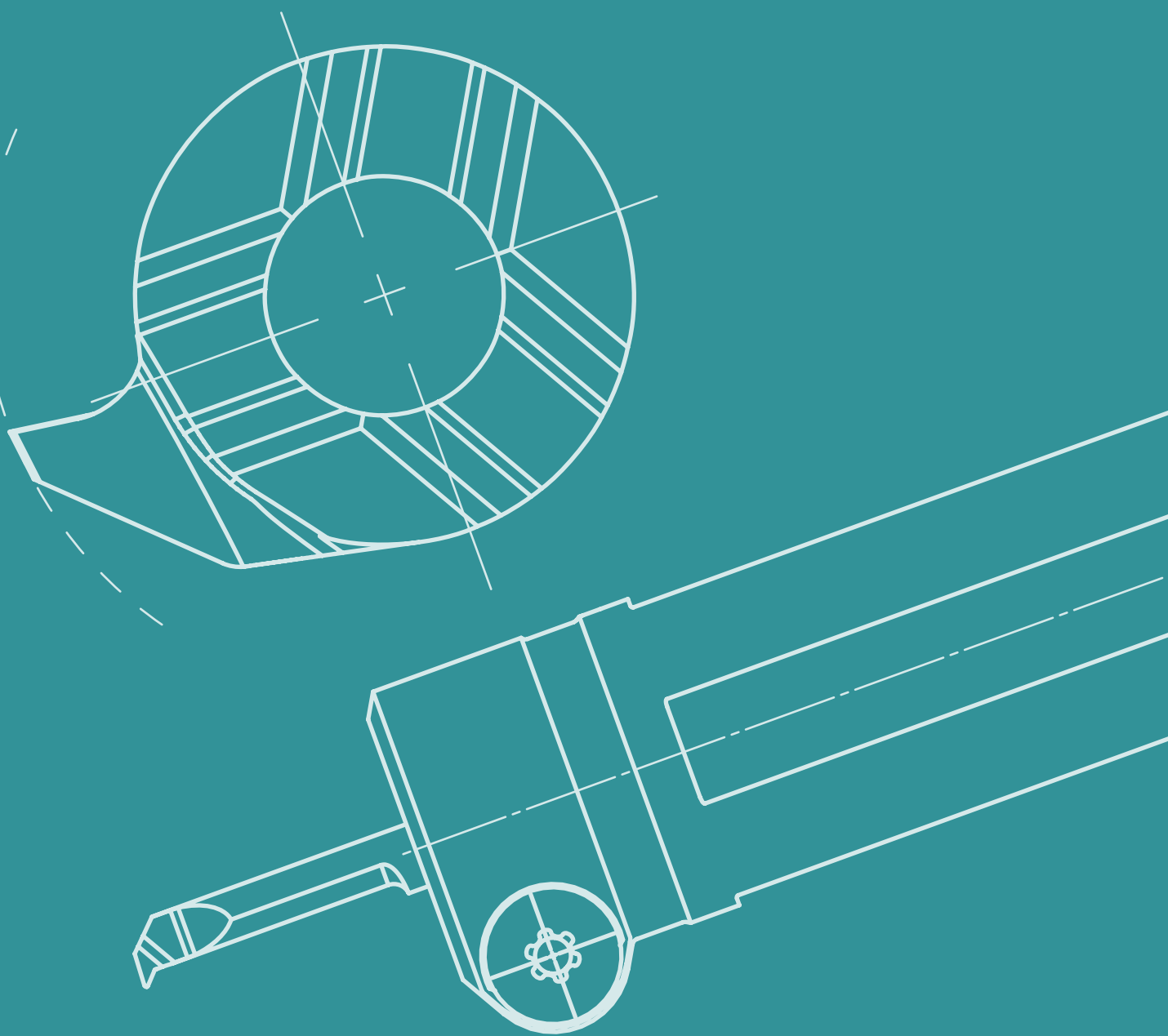

INTERNAL GROOVE TURNING

Semi Finishing VG-Cut	93
Finishing GrooVical	99
Laydown Grooving	105
Mini-V	117
microScope	141







INTERNAL MACHINING | **SEMI FINISHING**

VG-Cut

Internal Grooving & Turning Applications

Tech Guide

Recommended Cutting Speeds Vc [m/min] for Grooving and Turning

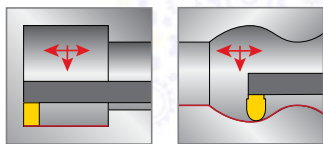

Material Group	Vargus No.	Material	Hardness Brinell HB	Carbide Grade			
				VMG PVD M35	VPG PVD P20	VKG CVD K25	
P Steel	1	Unalloyed Steel	Low Carbon (C=0.1-0.25%)	125	100-160	120-260	120-280
	2		Medium Carbon (C=0.25-0.55%)	150	80-140	90-220	90-250
	3		High Carbon (C=0.55-0.85%)	170	80-140	90-220	90-250
	4	Low Alloy Steel (alloying elements ≤5%)	Non Hardened	180	80-140	90-220	90-250
	5		Hardened	275	50-120	60-150	60-180
	6	High Alloy Steel (alloying elements >5%)	Annealed	200	50-100	90-150	90-250
	7		Hardened	325	40-70	50-100	60-160
	8	Cast Steel	Low Alloy (alloying elements <5%)	200	50-100	90-150	90-250
	9		High Alloy (alloying elements >5%)	225	50-100	60-150	60-180
	M Stainless Steel	11	Stainless Steel Ferritic	Non Hardened	200	50-80	60-160
12		Hardened		330	40-80	50-140	
13		Stainless Steel Austenitic	Austenitic	180	50-80	60-160	
14			Super Austenitic	200	50-80	60-160	
15		Stainless Steel Cast Ferritic	Non Hardened	200	50-80	60-160	
16			Hardened	330	40-80	50-140	
17		Stainless Steel Cast Austenitic	Austenitic	200	50-80	60-160	
18			Hardened	330	40-80	50-140	
K Cast Iron	28	Malleable Cast Iron	Ferritic (short chips)	130		160-200	160-280
	29		Pearlitic (long chips)	230		140-220	140-260
	30	Grey Cast Iron	Low Tensile Strength	180		160-200	160-280
	31		High Tensile Strength	260		100-200	100-240
	32	Nodular Sg Iron	Ferritic	160		100-200	100-240
	33		Pearlitic	260		100-200	100-240
N(K) Non-Ferrous Metals	34	Aluminum Alloys Wrought	Non Aging	60	150-300		
	35		Aged	100	150-250		
	36	Aluminum Alloys Cast	Cast	75	150-300		
	37		Cast & Aged	90	150-300		
	38	Aluminum Alloys Cast Si 13-22%	130	150-250			
	39	Copper and Copper Alloys	Brass	90	150-300		
	40		Bronze And Non Leaded Copper	100	150-300		
S(M) Heat Resistant Material	19	High Temperature Alloys	Annealed (iron based)	200	25-40	30-50	
	20		Aged (iron based)	280	25-35	20-50	
	21		Annealed (nickel or cobalt based)	250	25-35	20-50	
	22		Aged (nickel or cobalt based)	350	25-35	20-50	
	23	Titanium Alloys	Pure 99.5 Ti	400Rm	25-40	30-50	
24	α+β Alloys		1050Rm	25-60	30-70		
H(K) Hardened Material	25	Extra Hard Steel	Hardened & Tempered	45-50HRc		20-40	30-50
	26			51-55HRc		15-30	25-45

Vc [m/min] for Boring

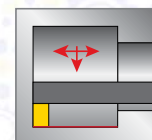

Reduce speed by ≈ 30% for improved chip forming and evacuation.

For gummy materials, such as stainless steel and heat resistant metals or in case of build up on edge (cold welding), **increase speed by ≈ 20%**.

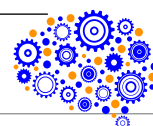

Feed Rate (f) Starting Point for Boring

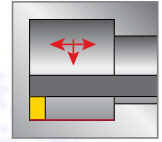

2.0 mm Insert Width

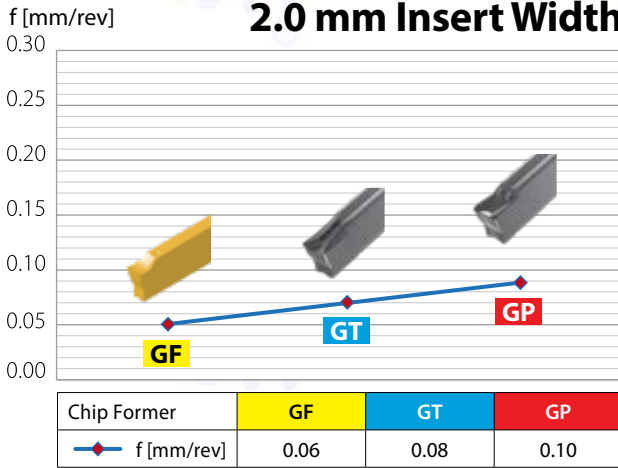

3.0 mm Insert Width

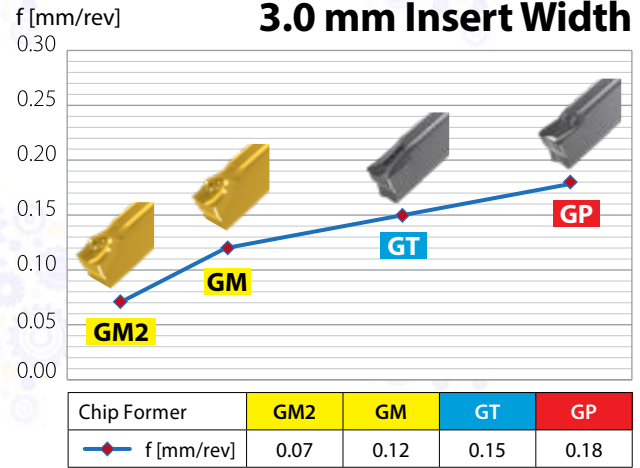

4.0 mm Insert Width

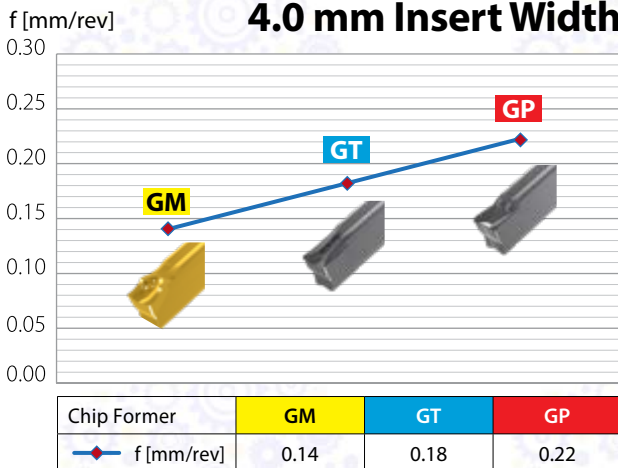

5.0 mm Insert Width

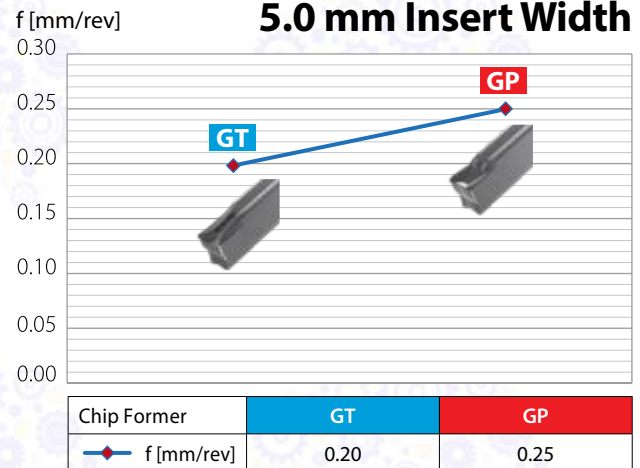

6.0 mm Insert Width

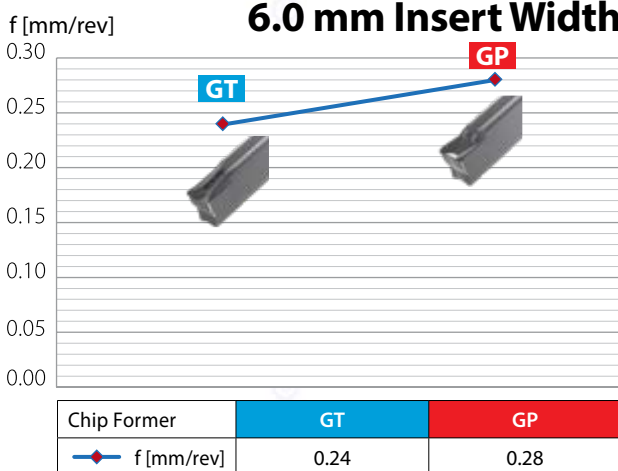

For better chip evacuation in Grooving, creating short chips is preferable. It is therefore recommended to work in short intervals (pecking), at a maximum grooving depth of twice the insert width. Taking into consideration the workpiece material and groove diameter, it is recommended to begin the first cut at no longer than the insert's width.

Reduce feed by 25% when exceeding machining depth of 3xD shank diameter.

Feed Rate (f) and Depth of Cut for Boring and Internal Profiling

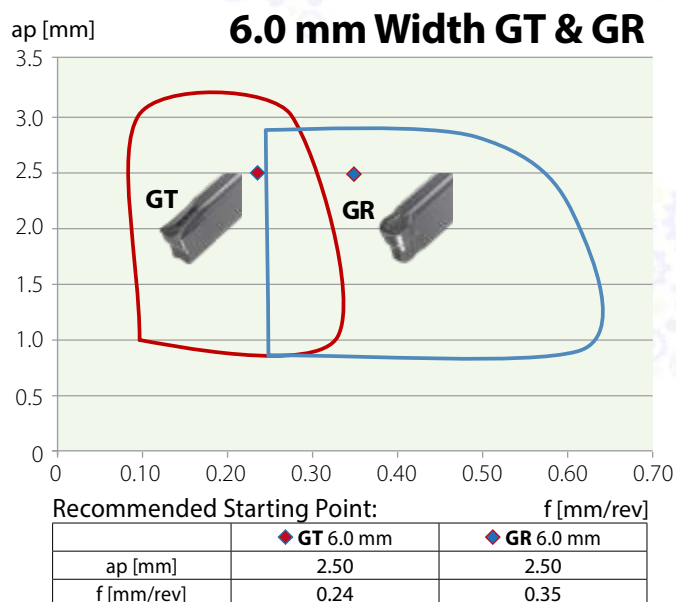
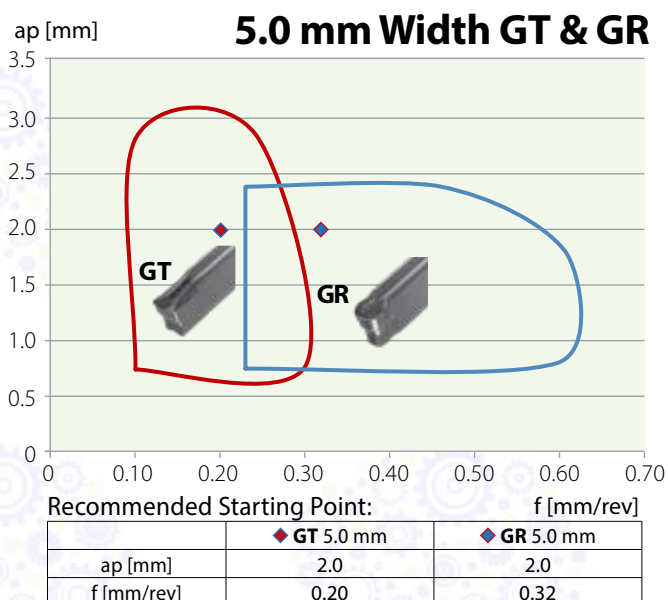
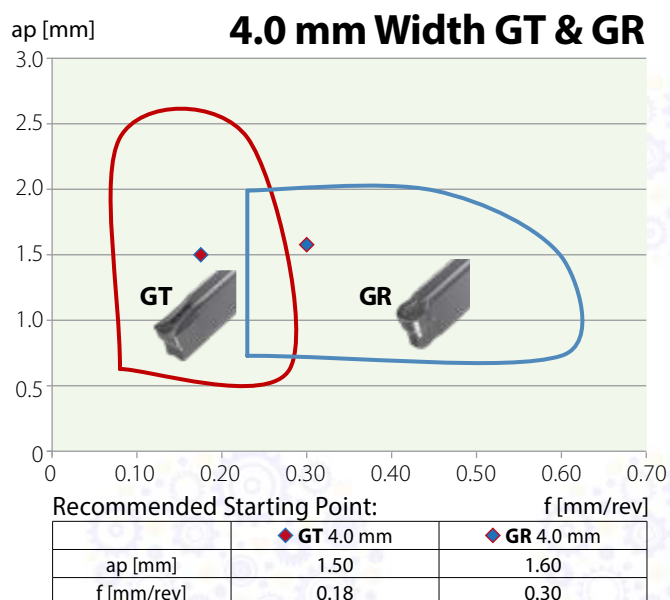
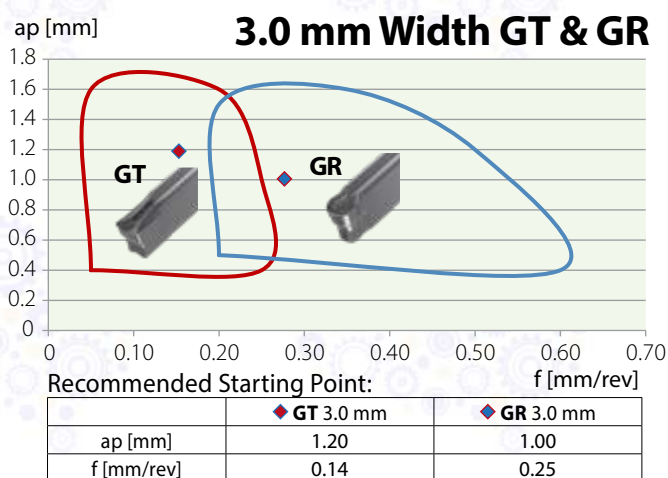
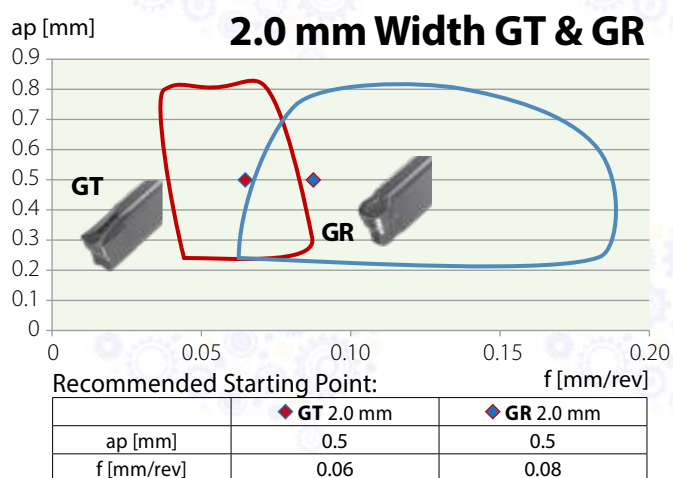
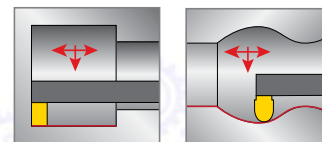

VG-Cut Internal Tools

Internal VG-Cut

98



VG-Cut Tools - Ordering Code System

VG	I	R	20-25	3	C
1	2	3	4	5	6

1 - Tools/Holders
VG - Grooving & Turning

2 - Type
I - Internal

3 - RH or LH
R - RH
L - LH

4 - Shank Diameter
Shank Dia. - D min. - Ex. 20-25

5 - Pocket Size
2, 3, 4, 5, 6

6 - Coolant
C - Coolant

ТОВ «СМАРТТЕК ІНЖИНІРИНГ», Т. +380-50-396-90-96, info@smarttec.com.ua, https://www.smarttec.com.ua



Internal VG-Cut

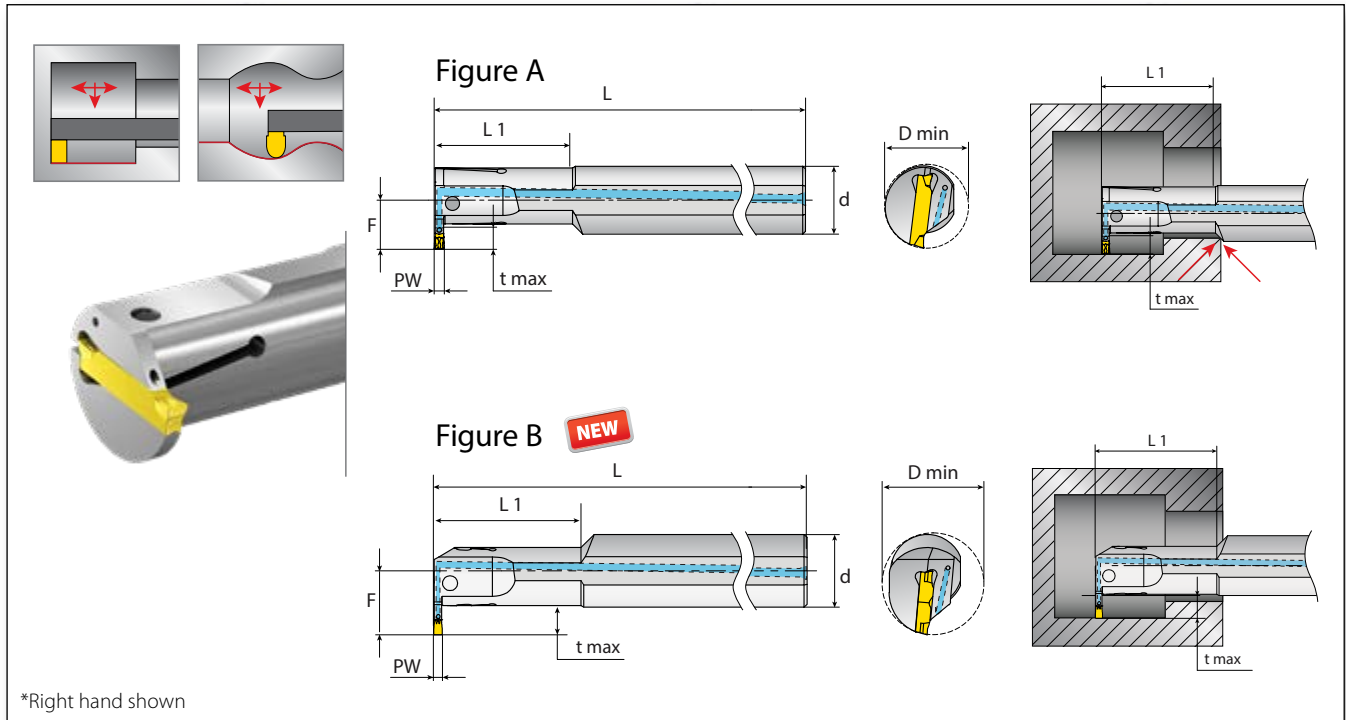

*Right hand shown

Figure A

Ordering Code		Dimensions mm						Spare Parts	
RH/LH	PW	t max	L1	D min	d	F	L	Screw*	Key
VGIR/L-20-25-2C	2	7	40.5	25	20	14.5	180	SM5x12	K4H
VGIR/L-25-32-2C		9	50.5	32	25	18.0	200		
VGIR/L-20-25-3C	3	7	40.5	25	20	14.4	180	SM5x16	
VGIR/L-25-32-3C		9	50.5	32	25	18.0	200	SM5x20	
VGIR/L-32-40-3C	4	11	64.0	40	32	22.0	250	SM5x12	
VGIR/L-20-28-4C		9	41.0	28	20	16.5	180	SM5x16	
VGIR/L-25-32-4C	5	9	51.0	32	25	18.0	200	SM5x20	
VGIR/L-32-40-4C		11	64.0	40	32	22.0	250		
VGIR-32-40-5C	5	11	64.0	40	32	22.0	250		

* Tightening Torque: For 2 PW holders - 4 Nm max.; For 3-6 PW holders - 7 Nm max.

For suitable VG-Cut inserts, please see page 23.

Figure B - Dimension L1 no longer limits machining on the axial plane

NEW

Ordering Code		Dimensions mm						Spare Parts	
RH/LH	PW	t max	L1	D min	d	F	L	Screw*	Key
VGIR/L-20-24-2C	2	7.5	40.0	24	20	17.5	180	SM5x12	K4H
VGIR/L25-31-2C		9.5	50.0	31	25	22.0	200	SM5X14	
VGIR/L-20-24-3C	3	7.5	40.0	24	20	17.5	180	SM5x12	
VGIR/L-25-31-3C		9.5	50.0	31	25	22.0	200	SM5X14	
VGIR/L-32-39-3C	4	11.5	63.0	39	32	27.5	250	SM5x12	
VGIR/L-20-27-4C		9.5	41.0	27	20	19.5	180	SM5X14	
VGIR/L-25-31-4C	5	9.5	50.0	31	25	22.0	200	SM5X14	
VGIR/L-32-39-4C		11.5	63.0	39	32	27.5	250		
VGIR-32-39-5C	5	11.5	63.0	39	32	27.5	250		
VGIR-40-50-6C	6	11.5	80.0	50	40	30.5	300	SM5X20	

* Tightening Torque: For 2 PW holders - 4 Nm max.; For 3-6 PW holders - 7 Nm max.

For suitable VG-Cut inserts, please see page 23.





INTERNAL MACHINING | **FINISHING**

Groovical

Precise Grooving & Turning Applications

Technical Guide

Recommended Grades and Cutting Data

Material Group	Vargus No.	Material	Hardness Brinell HB	Vc [m/min]	
				Coated	Uncoated
				VKX	VN020
P Steel	1	Unalloyed Steel	Low Carbon (C=0.1-0.25%)	125	140-200
	2		Medium Carbon (C=0.25-0.55%)	150	120-180
	3		High Carbon (C=0.55-0.85%)	170	110-180
	4	Low Alloy Steel (alloying elements ≤ 5%)	Non Hardened	180	100-155
	5		Hardened	275	110-180
	6		Hardened	350	80-135
	7	High Alloy Steel (alloying elements > 5%)	Annealed	200	70-115
	8		Hardened	325	50-100
	9	Cast Steel	Low Alloy (alloying elements < 5%)	200	30-50
	10		High Alloy (alloying elements > 5%)	225	20-40
M Stainless Steel	11	Stainless Steel Ferritic	Non Hardened	200	70-120
	12		Hardened	330	60-95
	13	Stainless Steel Austenitic	Austenitic	180	70-120
	14		Super Austenitic	200	40-90
	15	Stainless Steel Cast Ferritic	Non Hardened	200	80-110
	16		Hardened	330	65-110
	17	Stainless Steel Cast Austenitic	Austenitic	200	85-100
	18		Hardened	330	60-100
K Cast Iron	28	Malleable Cast Iron	Ferritic (short chips)	130	70-120
	29		Pearlitic (long chips)	230	70-120
	30	Grey Cast Iron	Low Tensile Strength	180	70-120
	31		High Tensile Strength	260	60-100
	32	Nodular Sg Iron	Ferritic	160	50-80
33	Pearlitic		260	60-90	
N(K) Non-Ferrous Metals	34	Aluminum Alloys Wrought	Non Aging	60	-
	35		Aged	100	-
	36	Aluminum Alloys	Cast	75	-
	37		Cast & Aged	90	-
	38	Aluminum Alloys	Cast Si 13-22%	130	-
	39	Copper and Copper Alloys	Brass	90	-
40	Bronze And Non Leaded Copper		100	-	
S(M) Heat Resistant Material	19	High Temperature Alloys	Annealed (iron based)	200	45-60
	20		Aged (iron based)	280	35-50
	21		Annealed (nickel or cobalt based)	250	20-30
	22		Aged (nickel or cobalt based)	350	15-25
	23	Titanium Alloys	Pure 99.5 Ti	400Rm	140-170
24	α+β Alloys		1050Rm	50-70	
H(K) Hardened Material	25	Extra Hard Steel	Hardened & Tempered	45-50HRc	45-60
	26			51-55HRc	40-50

! The maximum recommended **feed rate** is one-tenth of the insert width (W).

! The minimum recommended **depth of cut** is twice the corner radius (r).

VTX

Excellent for Grooving applications in medium-to-high cutting speeds and in dry conditions. Multi-layered AlTiN coated, general purpose grade for prevention of peeling and chipping.

* For **VTX Grade**, increase speed by 20%.

VKX

Standard grade for Grooving applications. Single-layered AlTiN+TiN coated.

VN020

NEW

Uncoated grade specially designed for Aluminum and Copper alloys. The high positive rake geometry and the sharp cutting edge of these inserts produce low forces while machining.

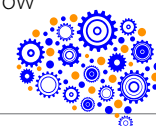

Recommended Feed Rate for Grooving & Turning Finishing Operations

Insert Width (mm)	High Alloy Steel, 330 HB, 2100 Kc [N/mm ²]		Austenitic Stainless Steel, 200 HB, 2600 Kc [N/mm ²]	
	Depth ap = Insert Width x variable	Average f mm/rev	Depth ap = Insert Width x variable	Average f mm/rev
0.4 mm - 0.9 mm	0.55	0.04	0.35	0.02
1.0mm - 1.5mm	0.55	0.07	0.35	0.04
1.6 mm - 2.0 mm	0.60	0.11	0.40	0.07
2.1 mm - 2.5 mm	0.60	0.14	0.40	0.09
2.6 mm - 3.0 mm	0.60	0.17	0.40	0.11
3.1 mm - 4.0mm	0.60	0.21	0.40	0.14
4.1 mm - 5.5 mm	0.60	0.28	0.40	0.19

- | The above recommendations are for achieving a stable and recurring tool life.
- | Exceeding higher feed rates may cause excessive wear and breakage.

D max Limitations

GV29 / GVN29 Internal - Depth of Groove in Relation to Bore Dia.

Dimensions mm	
t max	D min
0.5	41.8
1	42.3
1.5	42.8
2	43.5
2.5	44.2
3	45.1
3.5	46.1
4.0	47.2
4.5	48.3
5.0	49.9
5.5	54.2
6.0	73.5
6.5	104.5

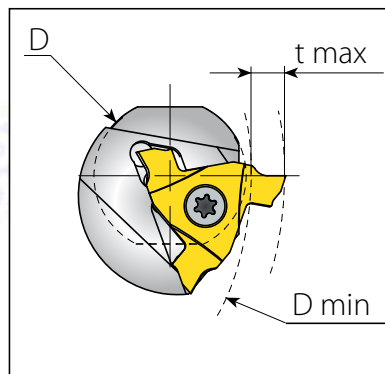

Groovical Holders

Close to Shoulder Internal Toolholders..... 103
 Internal Toolholders (GV29)..... 103

Groovical Holders - Ordering Code System

GVN	I	R	25	-	29
1	2	3	4		5

1 - Insert Type	2 - Type	3 - RH or LH	4 - Shank Size	5 - Insert Size
GVN - Groovical Close to Shoulder GV - Groovical Neutral	I - Internal	R - RH L - LH	25, 32 mm	29

I For **LH Internal** work applications use **LH toolholder** with **RH insert** and vice versa.

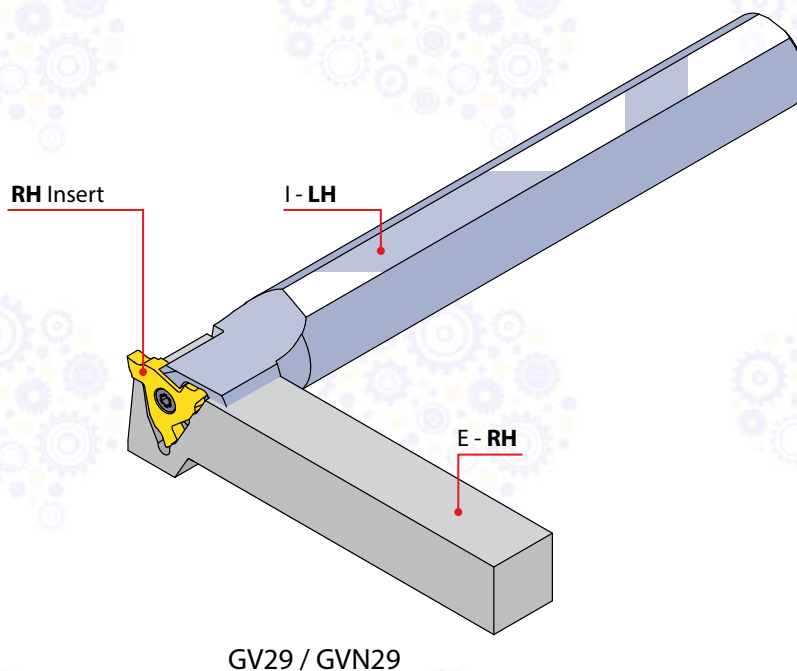

Close to Shoulder Internal Toolholders with Coolant

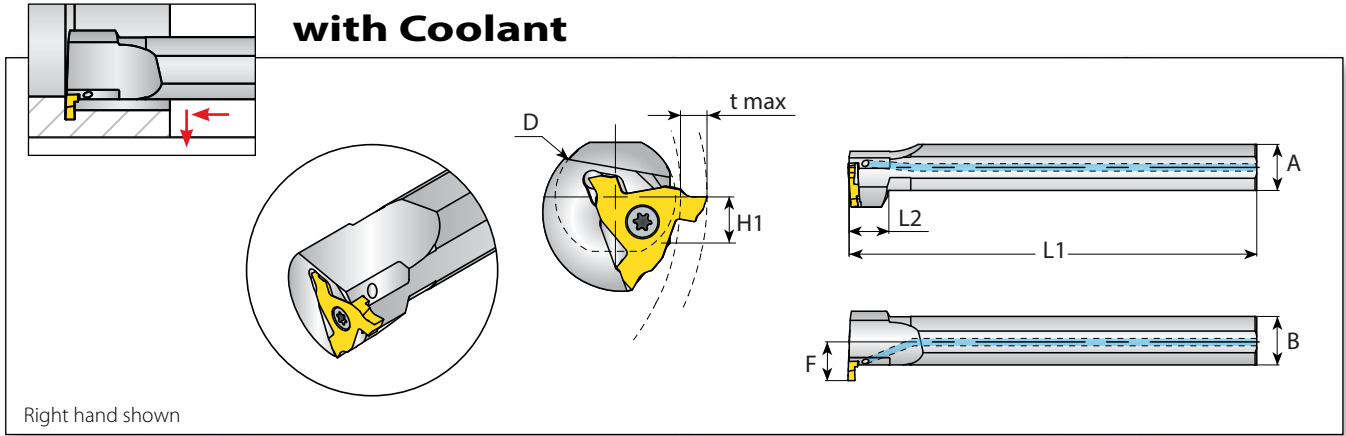

Insert Size	Ordering Code	Dimensions mm								Spare Parts		
		RH/LH	D	L1	L2	A	B	H1	F	t max/D max	Insert Screw*	Torx Key
29	GVNIR/L25-29		25	200	19	22.6	23.8	11.3	19.0	See page 101	SGM5	L20IP
	GVNIR/L32-29		32	250	19	29.0	30.5	14.5	22.2			

For suitable GVN29 inserts, please see pages 68-72.

* Tightening Torque 4.5 Nm.

Internal Toolholders (GV29) with Coolant

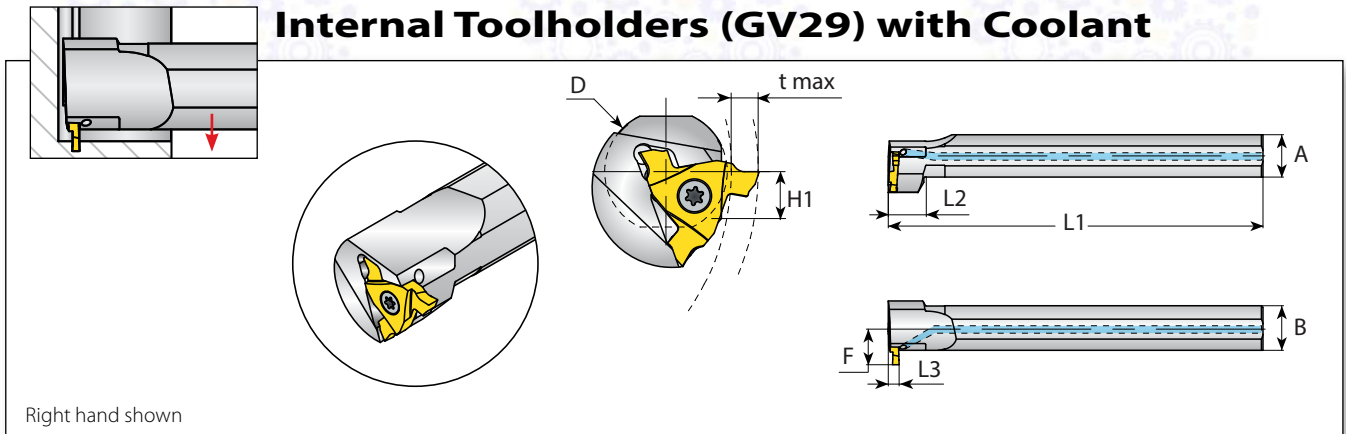

Insert Size	Ordering Code	Dimensions mm									Spare Parts		
		RH/LH	D	L1	L2	L3	A	B	H1	F	t max/D max	Insert Screw*	Torx Key
29	G VIR25-29		25	200	19	5.8	22.6	23.8	11.3	19.0	See page 101	SGM5	L20IP
	G VIR32-29		32	250	19	5.8	29.0	30.5	14.5	22.2			

For suitable GV29 inserts, please see page 73.

* Tightening Torque 4.5 Nm.



INTERNAL GROOVE TURNING | FINISHING

Laydown Grooving

For Shallow Grooves

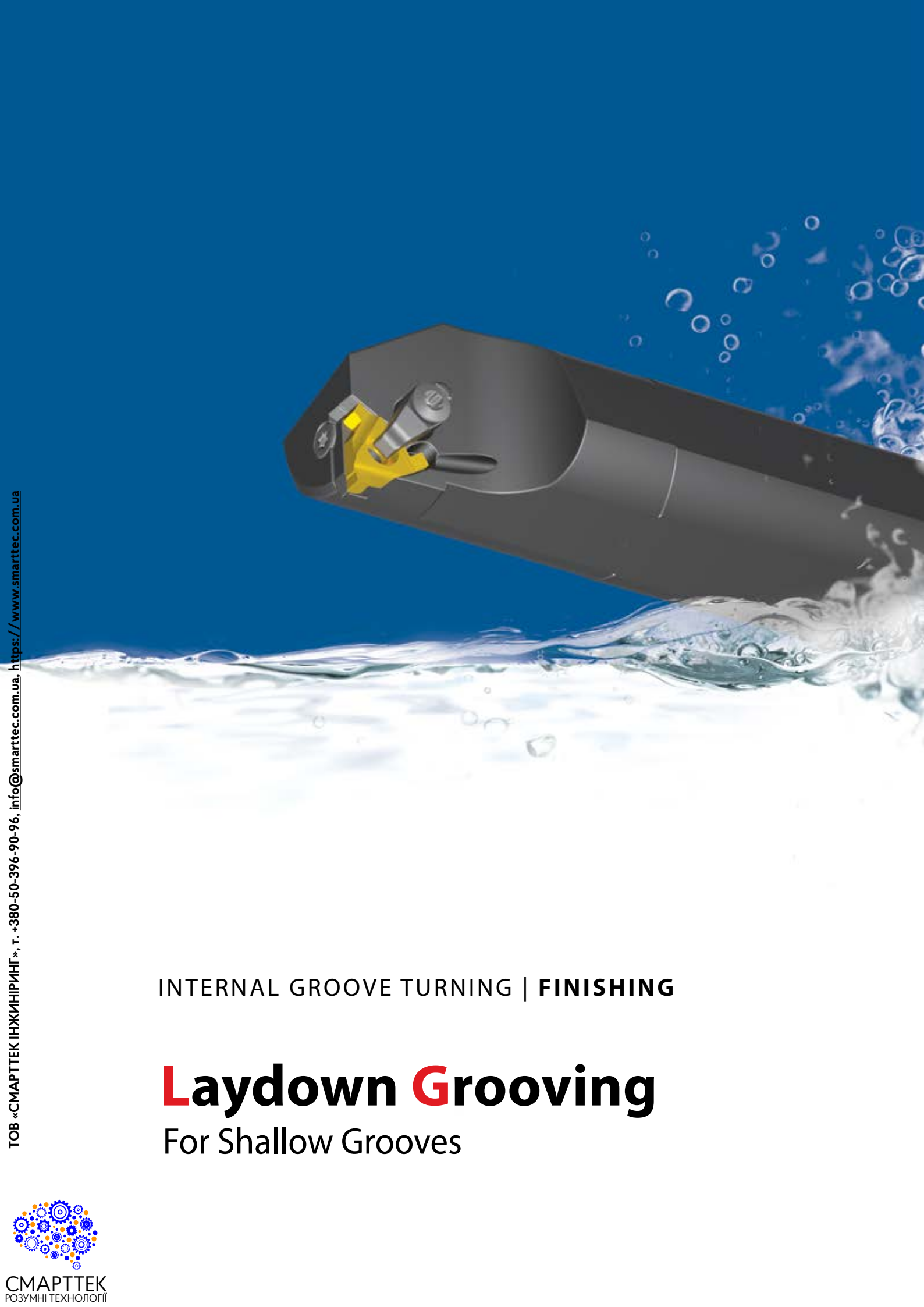



Technical Data

Recommended Grades, Cutting Speeds Vc [m/min] and Feed f [mm/rev]

Material Group	Vargus No.	Material	Hardness Brinell HB	Vc [m/min]		Feed [mm/rev]	
				Coated			
				VTX	VKX		
P Steel	1	Unalloyed steel	Low carbon (C=0.1-0.25%)	125	140-200	140-200	0.3
	2		Medium carbon (C=0.25-0.55%)	150	120-180	120-180	0.15
	3		High Carbon (C=0.55-0.85%)	170	110-180	110-180	0.05
	4	Low alloy steel (alloying elements ≤ 5%)	Non hardened	180	100-155	100-155	0.25
	5		Hardened	275	90-145	90-145	0.1
	6		Hardened	350	80-135	80-135	0.05
	7	High alloy steel (alloying elements >5%)	Annealed	200	70-115	65-115	0.2
	8		Hardened	325	50-100	50-100	0.05
	9	Cast steel	Low alloy (alloying elements <5%)	200	30-50	30-50	0.2
	10		High alloy (alloying elements >5%)	225	20-40	25-40	0.05
M Stainless Steel	11	Stainless steel Ferritic	Non hardened	200	70-120	80-120	0.2
	12		Hardened	330	60-95	55-95	0.05
	13	Stainless steel Austenitic	Austenitic	180	70-100	60-100	0.2
	14		Super Austenitic	200	40-90	50-90	0.05
	15	Stainless steel Cast Ferritic	Non hardened	200	80-110	60-80	0.2
	16		Hardened	330	65-110	45-65	0.05
	17	Cast austenitic	Austenitic	200	85-100	50-70	0.2
	18		Hardened	330	60-100	40-60	0.05
K Cast Iron	28	Malleable Cast iron	Ferritic (short chips)	130	70-120	60-80	0.2
	29		Pearlitic (long chips)	230	70-120	60-80	0.15
	30	Grey cast iron	Low tensile strength	180	70-120	60-80	0.2
	31		High tensile strength	260	60-100	40-70	0.1
	32	Nodular SG iron	Ferritic	160	50-80	60-80	0.2
	33		Pearlitic	260	60-90	70-90	0.1
N(K) Non-Ferrous Metals	34	Aluminum alloys Wrought	Non aging	60	100-240	80-240	0.4
	35		Aged	100	80-170	100-170	0.1
	36	Aluminum alloys	Cast	75	100-150	100-150	0.25
	37		Cast & aged	90	80-120	60-100	0.15
	38	Aluminum alloys	Cast Si 13-22%	130	100-150	100-150	0.15
	39	Copper and copper alloys	Brass	90	80-200	80-200	0.2
40	Bronze and non leaded copper		100	80-200	80-200	0.15	
S(M) Heat Resistant Material	19	High temperature alloys	Annealed (Iron based)	200	45-60	25-45	0.2
	20		Aged (Iron based)	280	35-50	20-30	0.05
	21		Annealed (Nickel or Cobalt based)	250	20-30	15-20	0.05
	22		Aged (Nickel or Cobalt based)	350	15-25	10-15	0.05
	23	Titanium alloys	Pure 99.5 Ti	400Rm	140-170	60-100	0.1
24	α+β alloys		1050Rm	50-70	40-50	0.05	
H(K) Hardned Material	25	Extra hard steel	Hardened & tempered	45-50HRC	45-60	20-40	0.02
	26			51-55HRC	40-50	20-35	0.02

Grades and Their Application

Grade	Application Type	Sample
VTX	General use carbide grade. A tough sub-micron substrate with TiAlN coating. Provides good fracture toughness and excellent wear resistance.	
VKX	Superior general purpose grade, excellent in steels and stainless steels, recommended for rigid cutting conditions TiN coated.	

Laydown Grooving Internal Inserts

DIN 472 Retaining Ring Grooves for Bores.....	108
DIN 7993 Snap Ring Grooves.....	109
CIRCLIP Inch Standard.....	110
DIN 76 Thread Undercuts.....	111

Laydown Grooving Inserts - Ordering Code System

3	I	R	1.1	C	D472	-	0.50	VTX
1	2	3	4	5	6		7	8

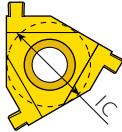
1 - Insert Size
3 - IC3/8"

2 - Type of Insert
I - Internal

3 - RH / LH Insert
R - Right Hand Insert L - Left Hand Insert

4 - Groove Std. Width
0.8 - 2.15 (mm)

5 - Profile Style
C - Full Profile

6 - Groove Standard
DIN 472 Partial DIN 472 DIN 7993 Partial DIN 7993 DIN 76 ST, DIN 76 SH CIR - CIRCLIP

7 - Groove Depth
0.33 - 2.0 (mm)

8 - Carbide Grade
VTX VKX

DIN 472 Retaining Ring Grooves for Bores

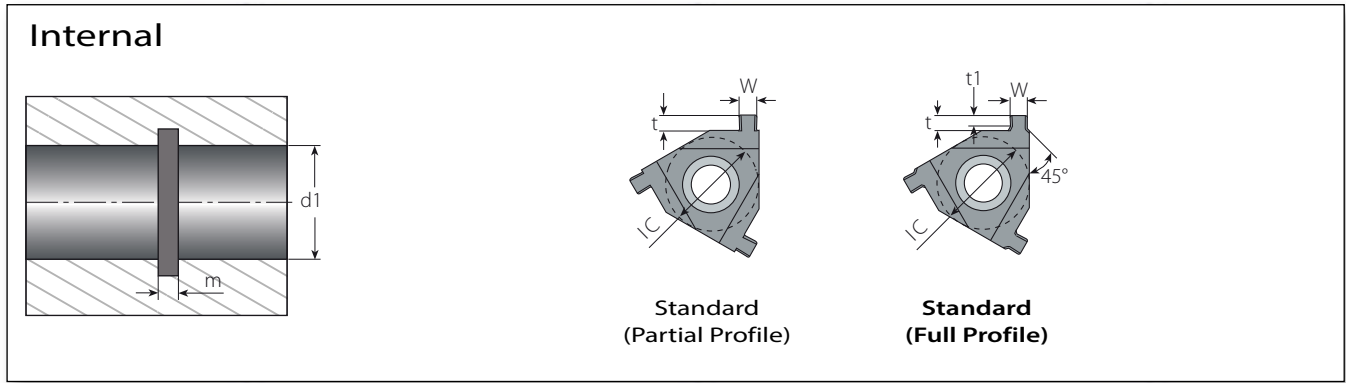

Standard (Partial Profile)

IC	Ordering Code	Groove Std.	Dimensions mm			Grade		Anvil	Holder
			m (H13)	W	t	VKX	VTX		
3/8"	3IR1.1D472-1.3		1.10	1.19	1.30	•	•	Y13M-1.5N	AVR.-3 NVR - 3
	3IR1.3D472-1.5		1.30	1.39	1.50	•	•		
	3IR1.6D472-1.8		1.60	1.69	1.80	•	•		
	3IR1.85D472-2.0		1.85	1.94	2.00	•	•		

Range of profiles also available on IC 1/4", 1/2" and 5/8", inserts on request.

• In stock • Available upon request

Standard (Full Profile)

IC	Ordering Code	Groove Std.	Dimensions mm				Grade		Anvil	Holder	
			d1	W	t1	t	VKX	VTX			
3/8"	3IR1.1CD472-0.50		1.10	18-22	1.19	0.36	0.50	•	•	Y13M-1.5N	AVR.-3 NVR - 3
	3IR1.3CD472-0.60		1.30	24-26	1.39	0.44	0.60	•	•		
	3IR1.3CD472-0.70		1.30	28-30	1.39	0.60	0.70	•	•		
	3IR1.3CD472-0.85		1.30	31-34	1.39	0.75	0.85	•	•		
	3IR1.6CD472-0.85		1.60	34	1.69	0.75	0.85	•	•		
	3IR1.6CD472-1.00		1.60	35-38	1.69	0.85	1.00	•	•		
	3IR1.85CD472-1.25		1.85	40-48	1.94	1.10	1.25	•	•		
	3IR2.15CD472-1.50		2.15	50-63	2.24	1.35	1.50	•	•		

Range of profiles also available on IC 1/4", 1/2" and 5/8", inserts on request.

• In stock • Available upon request

DIN 7993 Snap Ring Grooves

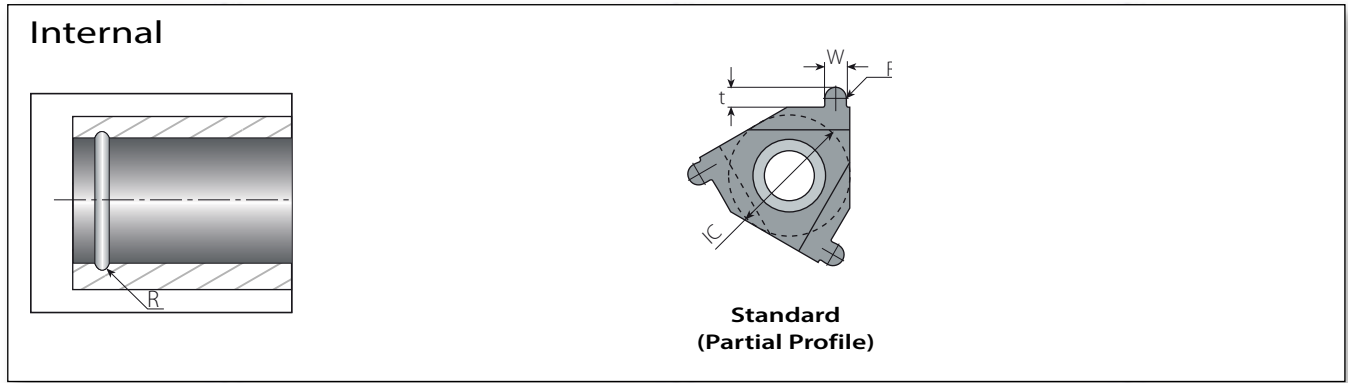

Standard (Partial Profile for Bores)



Insert Size	Ordering Code	Dimensions mm			Grade		Anvil	Holder
		R	W	t	VKX	VTX		
IC	RH	R	W	t	•	•		
3/8"	3IR0.6D7993-0.8	0.60	1.20	0.80	•	•	Y13M-1.5N	AVR.-3 NVR - 3
	3IR0.9D7993-1.1	0.90	1.80	1.10	•	•		
	3IR1.0D7993-1.2	1.00	2.00	1.20	•	•		

Range of profiles also available on IC 1/4", 1/2" and 5/8" inserts on request.

• In stock • Available upon request

CIRCLIP Inch Standard



Standard (Partial Profile)

	Insert Size	Ordering Code	Dimensions mm		Grade		Anvil	Holder
	IC	RH	W	t	VKX	VTX		
 3/8"		3IR.031CIRC-.05	.031	.05	•	•	Y13M-1.5N	AVR.-3* NVR - 3
		3IR.041CIRC-.07	.041	.07	•	•		
		3IR.047CIRC-.07	.047	.07	•	•		
		3IR.058CIRC-.08	.058	.08	•	•		
		3IR.062CIRC-.08	.062	.08	•	•		
		3IR.072CIRC-.08	.072	.08	•	•		
		3IR.078CIRC-.08	.078	.08	•	•		

Range of profiles also available on IC 1/4", 1/2" and 5/8", inserts on request.

• In stock • Available upon request



DIN 76 Thread Undercuts (For ISO Metric Threads in Accordance with DIN 13)

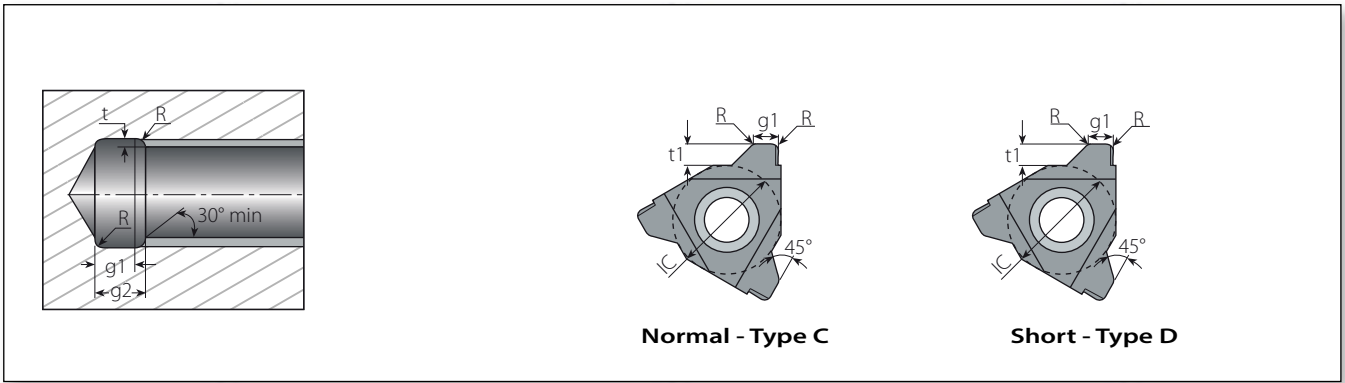

Standard (Normal - Type C)

Insert Size	Ordering Code	Pitch	Dimensions mm					Grade		Anvil	Holder
			mm	R	g1	g2	t	t1	VKX		
3/8"	3IR0.50D76ST-0.40	0.50	0.2	1.10	1.50	0.40	2.50	•	○	Y13M-1.5N	AVR...- 3 NVR...- 3
	3IR0.60D76ST-0.50	0.60	0.4	1.30	1.80	0.50	2.40	•	○		
	3IR0.70D76ST-0.55	0.70	0.4	1.55	2.10	0.55	2.20	•	○		
	3IR0.80D76ST-0.65	0.80	0.4	1.75	2.40	0.65	2.10	•	○		
	3IR1.00D76ST-0.80	1.00	0.6	2.20	3.00	0.80	1.90	•	○		

Range of profiles also available on IC 1/4", 1/2" and 5/8" inserts on request.

• In stock ○ Available upon request

Standard (Short - Type D)

Insert Size	Ordering Code	Pitch	Dimensions mm					Grade		Anvil	Holder
			mm	R	g1	g2	t	t1	VKX		
3/8"	3IR1.00D76SH-0.80	1.00	0.6	1.20	2.00	0.80	2.50	•	•	Y13M-1.5N	AVR...- 3 NVR...- 3
	3IR1.25D76SH-1.0	1.25	0.6	1.50	2.50	1.00	2.30	•	•		
	3IR1.50D76SH-1.15	1.50	0.8	1.85	3.00	1.15	2.10	•	•		
	3IR1.75D76SH-1.30	1.75	1.0	2.20	3.50	1.30	1.90	•	•		

Range of profiles also available on IC 1/4", 1/2" and 5/8" inserts on request.

• In stock ○ Available upon request

Laydown Grooving Internal Holders

Standard Toolholders.....	113
Standard Toolholders with Clamp.....	114
Standard Toolholders with Carbide Shank.....	115

Laydown Grooving Holders - Ordering Code System

Internal Holders

C	A	VR	C	20	-	3		
1	2	3	4	5		7	8	9

1- Shank Type B - Anti Vibration System C - Carbide Shank	2 - Anvil A - Anvil Required N - No Anvil Required	3 - Tool Type VR - Internal Round Shank	4 - Cooling C - With Coolant Channel	5 - Shank Front Dia 10, 10D, 12, 13, 16 16D, 20, 25, 25D, 32, 40, 50
--	---	---	--	---

7- Insert Size 3 - IC3/8"	8- Clamping C - With Clamp	9 - RH/LH Holder None - Right Hand LH - Left Hand
-------------------------------------	--------------------------------------	--

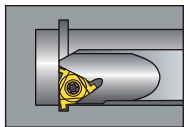

Internal Toolholders

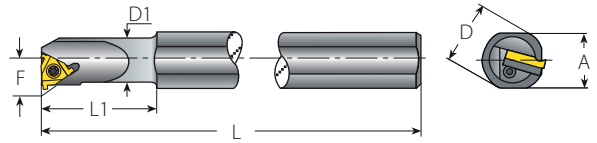

Standard

Spare Parts

Insert Size	Ordering Code	Dimensions mm							Min Bore Dia.	Spare Parts			
		IC	RH	A	L	L1	D	D1		F	mm	Insert Screw	Anvil Screw
1/4"	NVR10D-2	18.0	100	25	10	10.0	7.3	13					
	NVR10-2	18.0	180	25	20	10.0	7.3	13	SN2T	-	K2T	-	
	NVR13-2	18.0	180	32	20	13.0	8.9	16					
3/8"	NVR13-3	18.0	180	32	20	12.7	10.3	17					
	NVR16-3	18.0	180	40	20	16.0	11.5	20	SN3T	-	K3T	-	
	NVR16D-3	15.2	150	32	16	16.0	11.3	20					
	AVR20-3	18.0	180	40	20	20.0	13.4	24					
	AVR25-3	29.0	250	60	32	25.0	16.3	29					
	AVR25D-3	22.6	200	45	25	24.6	16.1	29	SA3T	SY3T	K3T	YI3M-1.5N	
	AVR32-3	29.0	250	60	32	32.0	19.6	36					
1/2"	AVR40-3	36.0	300	60	40	40.0	23.8	44					
	NVR20-4	18.0	180	50	20	20.0	15.6	27	SN4T	-	K4T	-	
	AVR25-4	29.0	250	60	32	25.0	17.4	32					
	AVR25D-4	22.6	200	45	25	24.6	17.2	32	SA4T	SY4T	K4T	YI4M-1.5N	
	AVR32-4	29.0	250	60	32	32.0	21.5	39					
5/8"	AVR40-4	36.0	300	60	40	40.0	25.8	47					
	AVR32-5	29.0	250	60	32	32.0	22.4	40	SN5T	SY5T	K5T	YI5M-1.5N	
	AVR40-5	36.0	300	60	40	40.0	26.4	48					
	AVR50-5	45.0	350	75	50	50.0	31.4	58	SA5T	SY5T	K5T	YI5M-1.5N	
	AVR60-5	54.0	400	75	60	60.0	36.4	69					

* The toolholders are supplied with standard anvils. For Grooving, please use the anvils indicated in the table above. Holders with coolant channel available as standard. For ordering code see page 112.



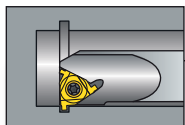

Internal Toolholders

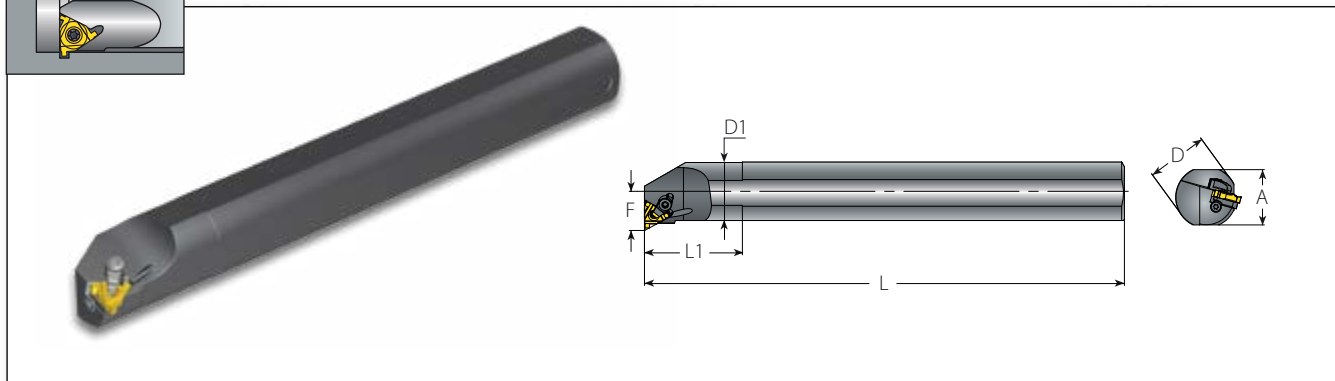

Standard with Clamp

(Dual System, Screw or Clamp)

Spare Parts

Insert Size	Ordering Code	Dimensions mm							Min Bore Dia.	Spare Parts				
IC	RH/LH	A	L	L1	D	D1	F	mm	Insert Screw	Anvil Screw	Clamp	Torx Key	Anvil RH	
3/8"	AVR20-3C	18.0	180	50	20	20.0	13.4	24	SA3T	SY3T	C3	K3CT	Y13M-1.5N	
	AVR25-3C	28.0	250	60	32	25.0	16.3	29						
	AVR25D-3C	22.6	200	45	25	24.6	16.1	29						
	AVR32-3C	29.0	250	60	32	32.0	19.6	36						
1/2"	AVR25-4C	29.0	250	60	32	25.0	17.4	32	SA4T	SY4T	C4	K4T	Y14M-1.5N	
	AVR25D-4C	22.6	200	45	25	24.6	17.2	32						
	AVR32-4C	29.0	250	60	32	32.0	21.5	39						
5/8"	AVR40-3C	36.0	300	60	40	40.0	23.8	44	SN5T	SY5T	C5	K5T	Y15M-1.5N	
	AVR32-5C	29.0	250	60	32	32.0	22.4	40						
	AVR40-5C	36.0	300	60	40	40.0	26.4	48						
	AVR50-5C	45.0	350	75	50	50.0	31.4	58						
	AVR60-5C	54.0	400	75	60	60.0	36.4	69	SA5T	SY5T	C5	K5T	Y15M-1.5N	

* The toolholders are supplied with standard anvils. For Grooving, please use the anvils indicated in the table above. Holders with coolant channel available as standard. For ordering code see page 112.



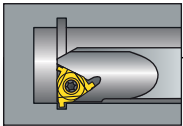



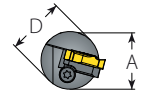
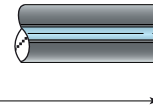
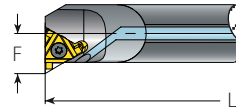

Internal Toolholders



Standard with Carbide Shank

Standard with Carbide Shank							Spare Parts			
Insert Size	Ordering Code	Min Bore Dia.								
IC	RH/LH	D	A	F	L	mm	Insert Screw	Anvil Screw	Torx Key	Anvil RH
1/4"	CNVRC10-2	10	9.5	7.3	150	13	SN2T	-	K2T	-
	CNVRC12-2	12	11.7	8.3	180	15				
3/8"	CNVRC16-3	16	15.6	11.5	200	20	SN3T	-	K3T	-
	CAVRC20-3	20	19.5	13.4	250	24	SA3T	SY3T	K3T	Y13M-1.5N
1/2"	CNVRC20-4	20	19.5	13.8	250	25	SN4T	-	K4T	-

* The toolholders are supplied with standard anvils. For Grooving, please use the anvils indicated in the table above. The above Toolholders have coolant channel as standard.

Carbide Shank toolholders should be used when extra accuracy is required or when the bar length to bar diameter ratio exceeds 3:1.

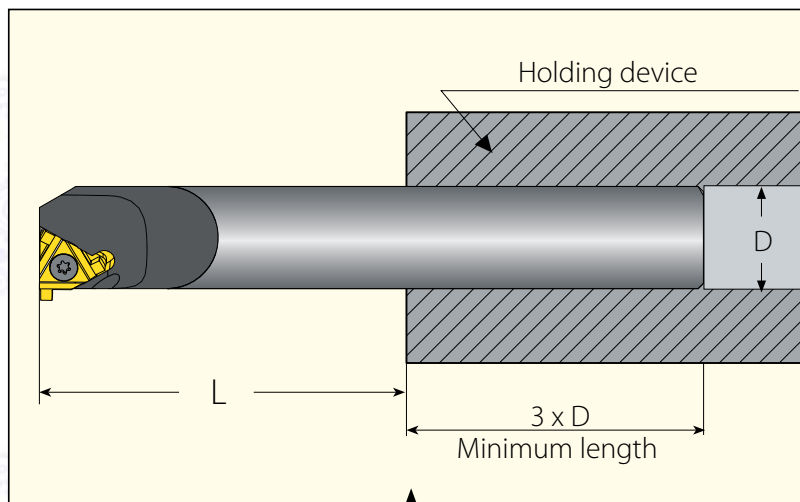

The overhang to bar diameter ratio should be as small as possible to eliminate the chance of chatter (vibration).

The minimum length inside a holding device should be 3 times the diameter of the bar shank.



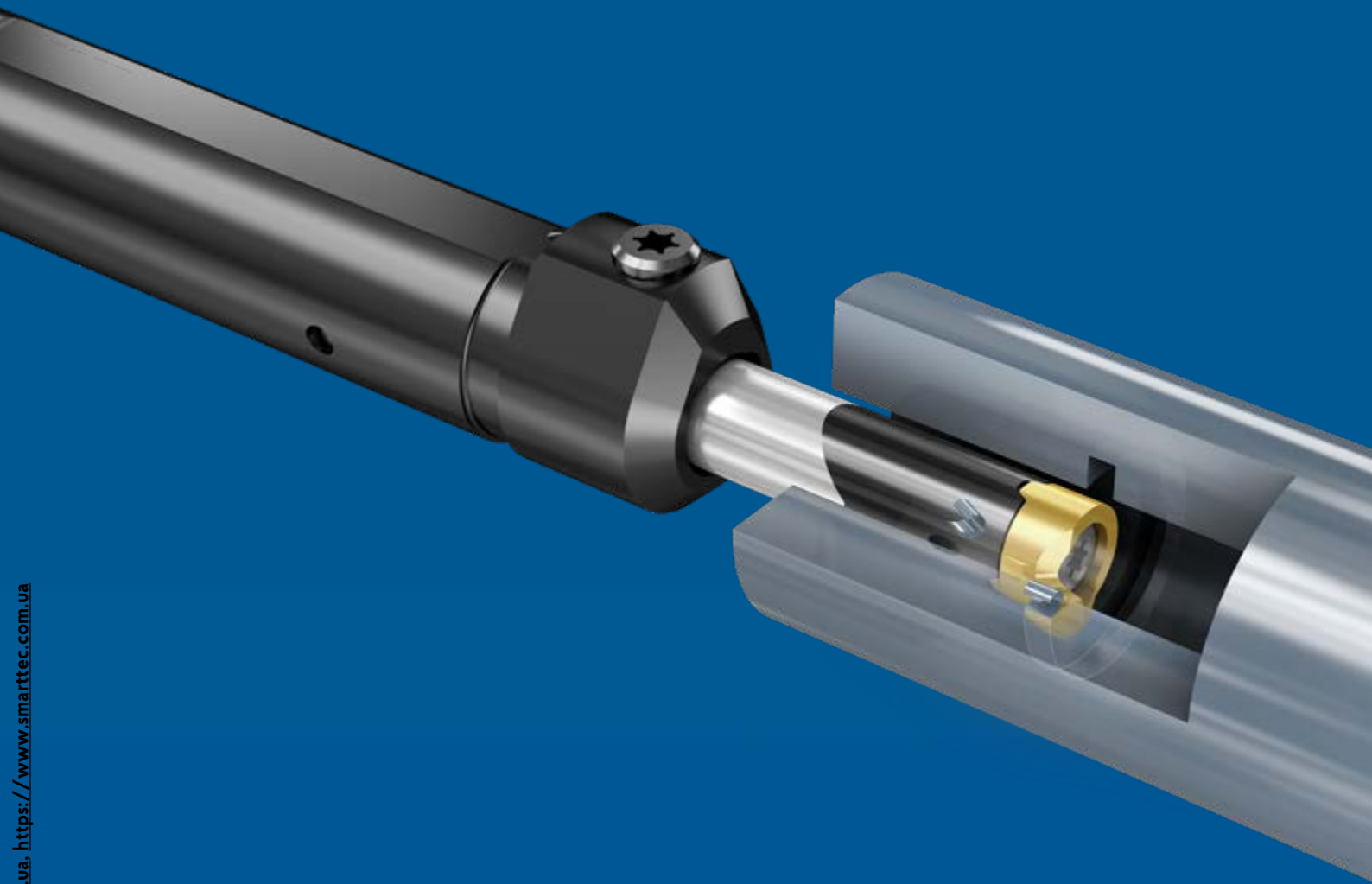

ТОВ «СМАРТТЕК ІНЖИНІРИНГ», Т. +380-50-396-90-96, info@smarttec.com.ua, <https://www.smarttec.com.ua>

INTERNAL GROOVE TURNING | **FINISHING**

Mini-V

Precise Turning, Grooving,
Threading & Face Grooving



СМАРТТЕК
РОЗУМНІ ТЕХНОЛОГІЇ

Mini-V

Mini Tools for Small & Medium Bores

The Mini-V line by **Groovex** offers improved solutions for mini boring, grooving and threading in bores starting from 7.8 mm.



Simple Clamping System

Double Cooling System
Effective chip evacuation and cooling of the cutting edge

Mini-VE Sizes 08 & 11

New Geometry for Inserts and Holders for Improved Performance and Better Chip Evacuation

NEW

Features and Benefits:

- Better chip evacuation
- Improved performance
- Available for boring, grooving, and threading inserts
- New Mini-VE 08 & 11 left-hand inserts available as standard
- New Mini-VE tools feature two flat areas for versatile mounting of the tool
- Mini-VE VE08 & VE11 inserts can be mounted on both VE & V tools
- RH and LH inserts can be mounted on the same tool

Ordering Code:

- New Mini-VE inserts and holders are marked with "E"
Insert example: VE08020BCR VTX
Holder example: CVE08-1221

Availability:

- Mini V inserts and tools available while supplies last

New Geometry

VE08 and VE11 inserts

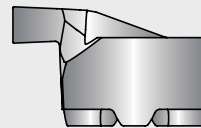

Previous Geometry

V08 and V11 inserts

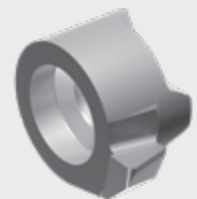
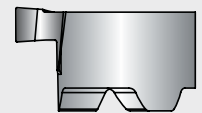

Applications

BORING

Pages 123 - 125

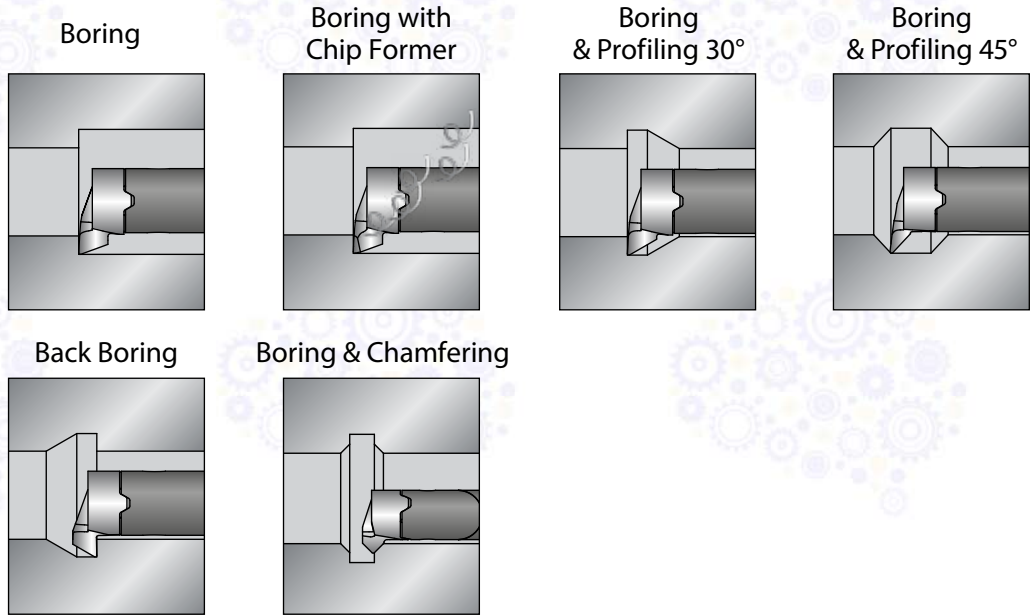

GROOVING

Pages 126 - 129

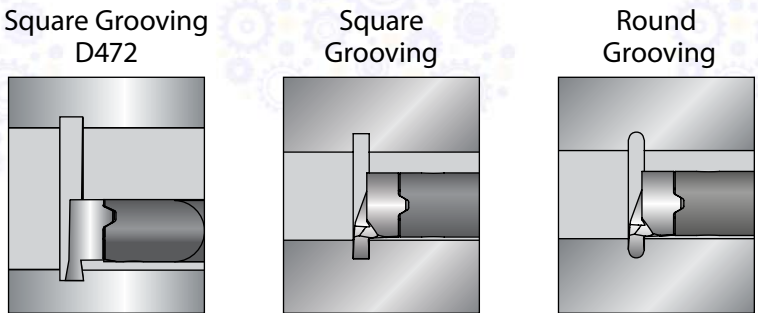

FACE GROOVING

Pages 130 - 131

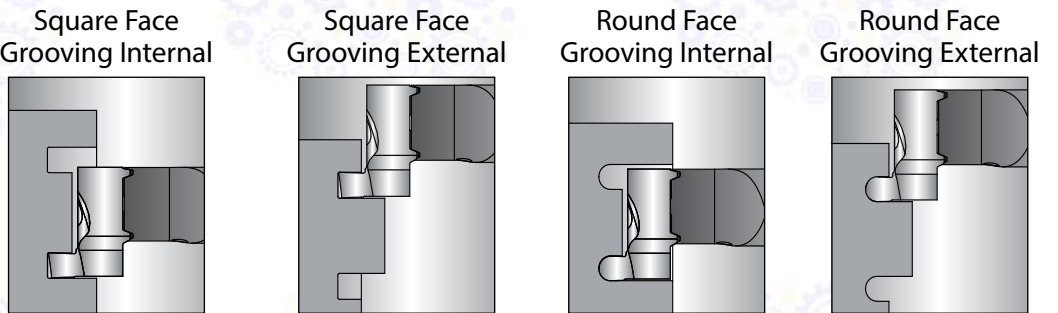

THREADING

Pages 132 - 134

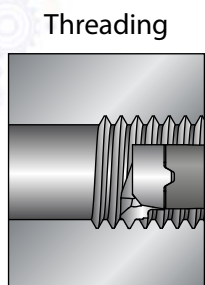

Mini-V Technical Data

Recommended Grades, Cutting Speeds Vc [m/min], Feed f [mm/rev] and Max. Depth [mm]

Material Group	Vargus No.	Material		Hardness Brinell HB	VBX		Max Depth on R [mm]
					Vc [m/min]		
					Threading	Grooving	Boring
P Steel	1	Unalloyed steel	Low carbon (C=1-.25%)	125	40-80	40-180	0.30-0.50
	2		Medium carbon (C=.25-.55%)	150	40-80	40-170	0.30-0.50
	3		High Carbon (C=.55-.85%)	170	40-80	40-160	0.25-0.35
	4	Low alloy steel (alloying elements≤5%)	Non hardened	180	40-80	40-155	0.28-0.45
	5		Hardened	275	40-80	40-160	0.25-0.45
	6		Hardened	350	40-80	40-150	0.25-0.40
	7	High alloy steel (alloying elements>5%)	Annealed	200	40-60	40-115	0.20-0.30
	8		Hardened	325	40-60	40-100	0.18-0.30
	9	Cast steel	Low alloy (alloying elements <5%)	200	40-60	40-170	0.20-0.30
	10		High alloy (alloying elements >5%)	225	40-60	40-130	0.17-0.30
M Stainless Steel	11	Stainless steel Ferritic	Non hardened	200	40-60	40-180	0.22-0.34
	12		Hardened	330	40-60	40-180	0.21-0.32
	13	Stainless steel Austenitic	Austenitic	180	40-60	40-140	0.25-0.40
	14		Super Austenitic	200	40-60	40-140	0.17-0.26
	15	Stainless steel Cast Ferritic	Non hardened	200	40-60	40-140	0.25-0.37
	16		Hardened	330	40-60	40-140	0.17-0.26
	17	Stainless steel Cast austenitic	Austenitic	200	40-60	40-120	0.20-0.30
	18		Hardened	330	40-60	40-120	0.17-0.26
K Cast Iron	28	Malleable Cast iron	Ferritic (short chips)	130	40-80	40-120	0.25-0.37
	29		Pearlitic (long chips)	230	40-80	40-100	0.20-0.30
	30	Grey cast iron	Low tensile strength	180	40-80	40-100	0.22-0.34
	31		High tensile strength	260	40-80	40-100	0.20-0.30
	32	Nodular SG iron	Ferritic	160	40-80	40-100	0.15-0.25
	33		Pearlitic	260	40-80	40-90	0.20-0.30
N(K) Non-Ferrous Metals	34	Aluminum alloys Wrought	Non aging	60	40-120	40-400	0.60-1.00
	35		Aged	100	40-120	40-400	0.50-0.90
	36	Aluminum alloys	Cast	75	40-120	40-400	0.50-0.90
	37		Cast & aged	90	40-120	40-200	0.40-0.60
	38	Aluminum alloys	Cast Si 13-22%	130	40-120	40-200	0.50-0.90
	39	Copper and Copper alloys	Brass	90	40-120	40-200	0.60-1.00
	40		Bronze and non leaded copper	100	40-120	40-200	0.50-0.90
	S(M) Heat Resistant Material	19	High temperature alloys	Annealed (Iron based)	200	20-30	20-30
20		Aged (Iron based)		280	20-30	20-30	0.10-0.20
21		Annealed (Nickel or Cobalt based)		250	15-20	15-20	0.08-0.20
22		Aged (Nickel or Cobalt based)		350	10-15	10-15	0.08-0.20
23		Titanium alloys	Pure 99.5 Ti	400Rm	40-60	40-60	0.10-0.20
24			α+β alloys	1050Rm	20-30	20-30	0.10-0.20

VTX

Excellent for Boring applications in medium-to-high cutting speeds and in dry conditions.

Multi-layered AlTiN PVD coated, general purpose grade for prevention of peeling and chipping.

* For **VTX Grade**, increase speed by 20%.

VBX

Excellent for all applications and outstanding wear resistance in low-to-medium cutting speeds, combined with good fracture toughness.

TiCN PVD coated.

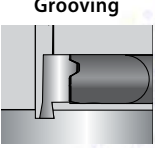
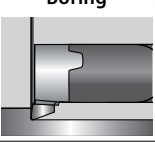

Feed Rate f [mm/rev]

 <p>Grooving</p>	0.02 - 0.05 mm/rev
 <p>Boring</p>	0.03 - 0.15 mm/rev

Threading

Depths of Cut and Number of Passes

- High pressure coolant is recommended
- Infeed method - modified flank infeed 1°

Option of modified volume chip

		Pitch mm	0.5	0.75	1	1.25	1.5	1.75	2	2.5	3	3.5	4			
		Pitch TPI	48	32	27	24	20	19	18	16	14	12	10	8	7	6
Insert Style	Standard	Passes (modified volume)														
VE08	ISO															
	UN	13	19		25	16			19	22						
	W															
	NPT				28				43							
	NPTF															
VE11	ISO															
	UN	13	19		25	16			19	22	24					
	W															
	BSPT						19									
V14	ISO															
	UN	7	10		13	16			19	22	24	32	38			
	W															
V16	ISO															
	UN	7	10		13	16			19	22	24	32	38			
	W															

Option of constant depth chip

		Pitch mm	0.5	0.75	1	1.25	1.5	1.75	2	2.5	3	3.5	4			
		Pitch TPI	48	32	27	24	20	19	18	16	14	12	10	8	7	6
Insert Style	Standard	Passes (same)														
VE08	ISO															
	UN	11-24	17-35		23-48	18-28			21-34	25-40						
	W															
	NPT				25-53				40-83							
	NPTF															
VE11	TR									50-104		70-145				
	ISO															
	UN	11-24	17-35		23-48	14-28			17-34	20-40	23-46					
	W															
V14	BSPT						21-34									90-187
	TR															
	ISO															
V16	UN	11-24	17-35		23-48	14-28			9-15	11-18	11-18	12-21	18-24			
	W															

Number of passes can be decreased when high pressure coolant is used.

Mini-V Inserts

Boring.....	123	Square Grooving - 0.05 mm Corner Radius.....	127
Boring with Chip Former.....	123	Square Grooving.....	128
Boring & Profiling 30°.....	124	Round Grooving - DIN 7993.....	129
Boring & Profiling 45°.....	124	Square Face Grooving.....	130
Back Boring.....	125	Round Face Grooving.....	131
Boring & Chamfering.....	125	Threading.....	132
Grooving DIN 472 - Sharp Corner Radius.....	126		

Mini-V Inserts - Ordering Code System

Boring Inserts

V	08	CL		R	VBX
1	2	3	4	5	6

1- Line Name
VE - Mini-V Improved Geometry Inserts (sizes 08 & 11) V - Mini-V Inserts (sizes 14 & 16)

2 - Insert Size
08, 11, 14, 16

3 - Type of Application
BC - Boring BCF - Boring with Chip Former CL - Boring & Profiling BB - Back Boring CH45 - Boring & Profiling 45°

4 - Copy Angle
None - Profiling 20° 3 - Profiling 30° CL+ None - Profiling 45°

5 - RH or LH	6 - Carbide Grade
R - RH L - LH	VTX VBX

Grooving Inserts

V	08	GS	W120	T 100	R	VBX
1	2	3	4	5	6	7

1- Line Name
VE - Mini-V Improved Geometry Inserts (sizes 08 & 11) V - Mini-V Inserts (sizes 14 & 16)

2 - Insert Size
08, 11, 14, 16

3 - Type of Application
D472 - Square Grooving Sharp Corner Radius GS - Square Grooving 0.05 mm Corner Radius GSR - Square Grooving D7993 - Round Grooving D7993 FGW - Square Face Grooving Internal FGR - Round Face Grooving Internal FEGW - Square Face Grooving External FEGR - Round Face Grooving External

4 - Groove Width
W070 - 0.7 mm W080 - 0.8 mm W090 - 0.9 mm W100 - 1.0 mm W110 - 1.1 mm W120 - 1.2 mm W130 - 1.3 mm W150 - 1.5 mm W160 - 1.6 mm W180 - 1.8 mm W200 - 2.0 mm W250 - 2.5 mm W300 - 3.0 mm W350 - 3.5 mm W400 - 4.0 mm

5 - Groove Depth	6 - RH or LH	7 - Carbide Grade
T100 - 1.0 mm T230 - 2.3 mm T400 - 4.0 mm T430 - 4.3 mm	R - RH L - LH	VTX VBX

Threading Inserts

V	08	TH	.5	ISO	R	VBX
1	2	3	4	5	6	7

1- Line Name
VE - Mini-V Improved Geometry Inserts (sizes 08 & 11) V - Mini-V Inserts (sizes 14 & 16)

2 - Insert Size
08, 11, 14, 16

3 - Type of Application
TH - Threading

4 - Pitch (for Threading)			
Full Profile - Pitch Range			
TPI	mm		
32-12	0.5-2.0		
Partial Profile - Pitch Range			
	TPI		mm
H	48-32	H	0.5-.75
I	24-20	I	1.0-1.25
J	16-14	J	1.5-1.75
G	14-8	G	1.75-3.0
AG	48-8	AG	0.5-3.0

5 - Threading Standard
60° - Partial Profile 60° 55° - Partial Profile 55° ISO - ISO Metric UN - American UN W - Whitworth for BSW, BSP BSPT - British Standard Pipe Thread NPT - NPT National Pipe Thread NPTF - NPTF National Seal Pipe Thread TR - Trapez Din 103

6 - RH or LH
R - RH L - LH

7 - Carbide Grade
VBX VTX



Boring

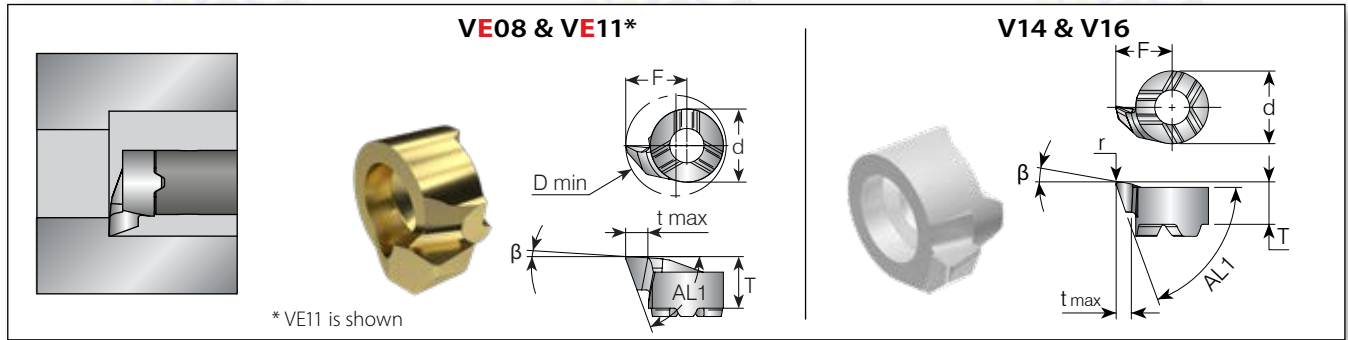

VE08 & VE11 | Mini-VE

Insert Style	Ordering Code	Dimensions mm							Min. Bore Dia. mm	Grade	
		RH/LH	r	d	T	t max	AL1	β			F
VE08	VE08020BCR/L		0.2	6.0	4.45	1.3	70°	8°	4.65	7.8	•
VE11	VE11020BCR/L		0.2	8.0	5.65	2.3	70°	3°	6.7	11.0	•

• In stock ◦ Available upon request

V14 & V16

Insert Style	Ordering Code	Dimensions mm							Min. Bore Dia. mm	Grades		
		RH	r	d	T	t max	AL1	β		F	VBX	VTX
V14	V14BC R		0.2	9	5.6	4.0	69.8°	8°	8.7	13.8	•	•
V16	V16BC R		0.2	11	5.6	4.3	69.8°	5.5°	9.7	15.5	•	•

• In stock ◦ Available upon request

Boring with Chip Former



VE08 & VE11 | Mini-VE

Insert Style	Ordering Code	Dimensions mm							Min. Bore Dia. mm	Grade	
		RH/LH	r	d	T	t max	AL1	β			F
VE08	VE08020BCFR/L		0.2	6.0	4.45	1.3	70°	8°	4.65	7.8	•
VE11	VE11020BCFR/L		0.2	8.0	5.65	2.3	70°	3°	6.7	11.0	•

• In stock ◦ Available upon request

ТОВ «СМАРТТЕК ІНЖИНІРИНГ», Т. +380-50-396-90-96, info@smarttec.com.ua, https://www.smarttec.com.ua



Boring & Profiling 30°



VE08 & VE11 | Mini-VE

Insert Style	Ordering Code	Dimensions mm								Min. Bore Dia.	Grade
	RH/LH	r	d	T	t max	AL1	β	F	mm	VTX	
VE08	VE08020P30R/L	0.2	6.0	4.45	1.3	58°	8°	4.65	7.8	•	
VE11	VE11020P30R/L	0.2	8.0	5.65	2.3	58°	3°	6.70	11.0	•	

- In stock ◦ Available upon request

Boring & Profiling 45°

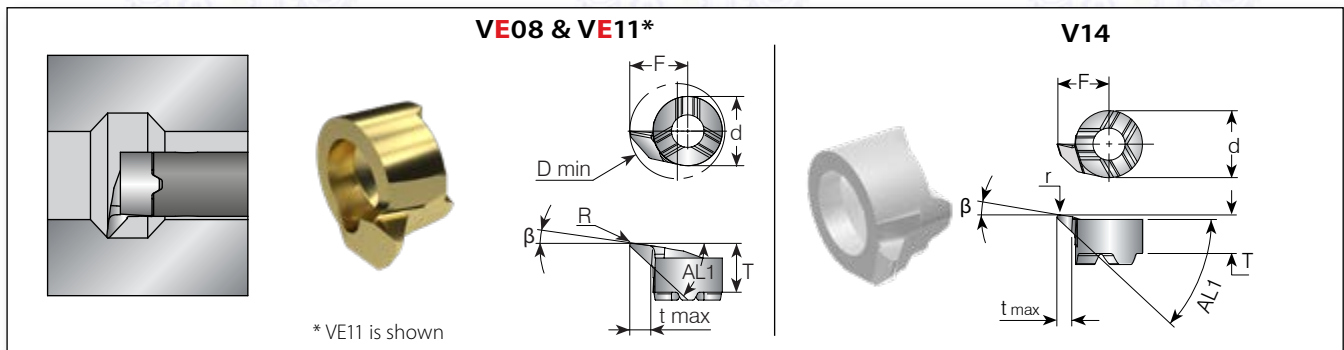

VE08 & VE11 | Mini-VE

Insert Style	Ordering Code	Dimensions mm								Min. Bore Dia.	Grade
	RH/LH	r	d	T	t max	AL1	β	F	mm	VTX	
VE08	VE08020P47R/L	0.2	6.0	4.45	1.3	43°	5.5°	4.65	7.8	•	
VE11	VE11020P47R/L	0.2	8.0	5.65	2.3	43°	7°	6.70	11.0	•	

- In stock ◦ Available upon request

V14 & V16

Insert Style	Ordering Code	Dimensions mm								Min. Bore Dia.	Grades
	RH	r	d	T	t max	AL1	β	F	mm	VBX	VTX
V14	V14CL R	0.2	9	5.6	4.0	43°	6°	8.7	13.7	•	•
V16	V16CL R	0.2	11	5.6	4.3	43°	6°	10.2	15.8	•	•

- In stock ◦ Available upon request



Back Boring

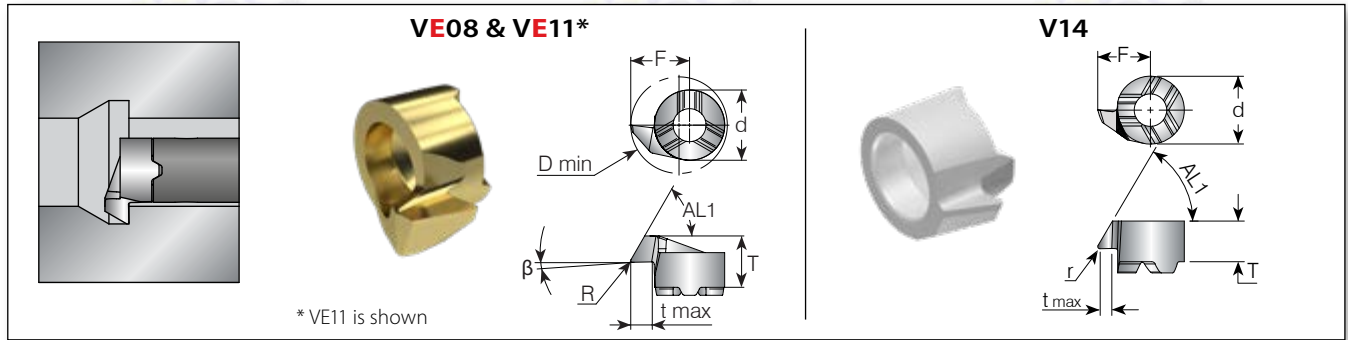

VE08 & VE11 | Mini-VE

Insert Style	Ordering Code	Dimensions mm								Min. Bore Dia.	Grade
		RH/LH	r	d	T	t max	AL1	β	F	mm	VTX
VE08	VE08020BBR/L		0.2	6	4.6	1.2	60°	4.65	4.65	7.8	•
VE11	VE11020BBR/L		0.2	8	5.85	2.2	60°	6.7	6.70	11.0	•

• In stock ◦ Available upon request

V14

Insert Style	Ordering Code	Dimensions mm							Min. Bore Dia.	Grades	
		RH	r	d	T	t max	AL1	F	mm	VBX	VTX
V14	V14BB R		0.2	9	5.6	3.5	59.5°	8.70	13.8	•	•

• In stock ◦ Available upon request

Boring & Chamfering 45°

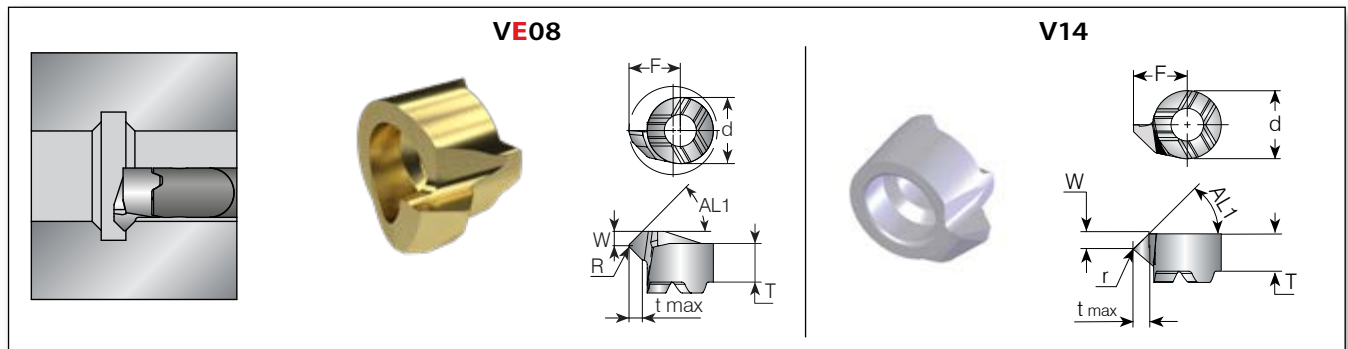

VE08 | Mini-VE

Insert Style	Ordering Code	Dimensions mm								Min. Bore Dia.	Grade
		RH/LH	r	d	W ^{+0.03}	T	t max	AL1	F	mm	VTX
VE08	VE08020CH45R/L		0.2	6	1.3	4.6	1.2	45°	4.65	7.8	•

• In stock ◦ Available upon request

V14

Insert Style	Ordering Code	Dimensions mm							Min. Bore Dia.	Grades		
		RH	r	d	W ^{+0.03}	T	t max	AL1	F	mm	VBX	VTX
V14	V14CH45 R		0.2	9	2.7	5.6	2.6	45°	9	14.0	•	•

• In stock ◦ Available upon request

ТОВ «СМАРТТЕК ІНЖИНІРИНГ», Т. +380-50-396-90-96, info@smarttec.com.ua, https://www.smarttec.com.ua

Grooving DIN 472 - Sharp Corner Radius

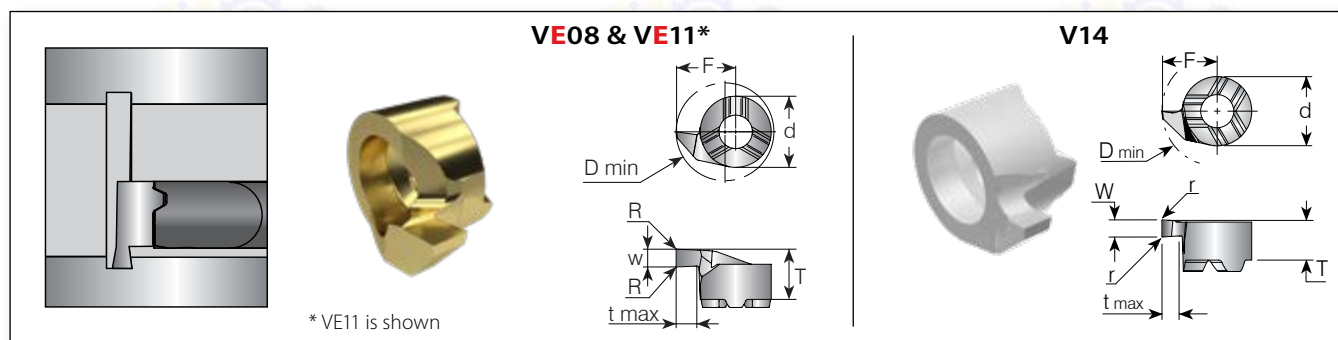

VE08 & VE11 | Mini-VE

Insert Style	Ordering Code	Width of Circlip		Dimensions mm					Min. Bore Dia.	Grade
		mm	W ^{+0.03}	d	t max	T	F	r		
VE08	VE0800GSW070T100R/L	0.7	0.73	6	1.0	4.4	4.8	0	8	○
	VE0800GSW080T100R/L	0.8	0.83							●
	VE0800GSW090T100R/L	0.9	0.93							○
	VE0800GSW110T100R/L	1.1	1.20							○
	VE0800GSW130T100R/L	1.3	1.40							○
	VE0800GSW160T100R/L	1.6	1.70							○
VE11	VE1100GSW070T120R/L	0.7	0.73	8	1.2	5.7	6.7	0	11	○
	VE1100GSW080T130R/L	0.8	0.83		1.3					●
	VE1100GSW090T150R/L	0.9	0.93		1.5					○
	VE1100GSW110T220R/L	1.1	1.20		2.2					○
	VE1100GSW130T220R/L	1.3	1.40		2.2					○
	VE1100GSW160T220R/L	1.6	1.70		2.2					○

● In stock ○ Available upon request

V14

Insert Style	Ordering Code	Width of Circlip		Dimensions mm					Min. Bore Dia.	Grades	
		mm	W ^{+0.03}	d	t max	T	F	r		D min	VBX
V14	V14D472 W130T400 R	1.3	1.40	9	4.3	5.6	9	0	14	●	●
	V14D472 W160T400 R	1.6	1.70							●	●

● In stock ○ Available upon request

Square Grooving - 0.05 mm Corner Radius

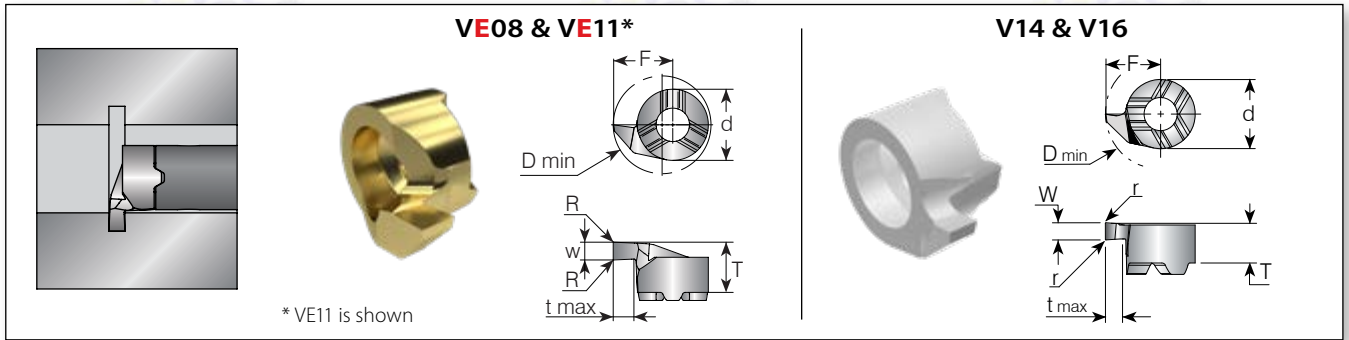

VE08 & VE11 | Mini-VE

Insert Style	Ordering Code	Dimensions mm						Min. Bore Dia.	Grade	
		RH/LH	d	W ^{+0.03}	t max	T	F			r
VE08	VE08005GS W078T100R/L		6	0.78	1.0	4.4	4.8	0.05	8	○
	VE08005GS W086T100R/L		0.86	○						
	VE08005GS W100T100R/L		1.00	●						
	VE08005GS W117T100R/L		1.17	○						
	VE08005GS W150T100R/L		1.50	●						
	VE08005GS W157T100R/L		1.57	○						
	VE08005GS W198T100R/L		1.98	○						
	VE08005GS W200T100R/L		2.00	●						
VE11	VE11005GS W100T230R/L		8	1	2.3	5.7	6.7	0.05	11	●
	VE11005GS W117T230R/L		1.17	○						
	VE11005GS W120T230R/L		1.2	○						
	VE11005GS W142T230R/L		1.42	○						
	VE11005GS W150T230R/L		1.5	●						
	VE11005GS W157T230R/L		1.57	○						
	VE11005GS W198T230R/L		1.98	○						
	VE11005GS W200T230R/L		2	●						
	VE11005GS W238T230R/L		2.38	○						
	VE11005GS W250T230R/L		2.5	○						
VE11005GS W318T230R/L		3.18	○							

● In stock ○ Available upon request

V14 & V16

Insert Style	Ordering Code	Dimensions mm						Min. Bore Dia.	Grades		
		RH	d	W ^{+0.03}	t max	T	F		r	VBX	VTX
V14	V14GS W117T400 R		9	1.17	4.0	5.6	9.0	0.05	14	●	●
	V14GS W150T400 R		1.50	●						●	
	V14GS W157T400 R		1.57	●						●	
	V14GS W198T400 R		1.98	●						●	
	V14GS W200T400 R		2.00	●						●	
	V14GS W238T400 R		2.38	●						●	
	V14GS W250T400 R		2.50	●						●	
	V14GS W300T400 R		3.00	●						●	
	V14GS W318T400 R		3.18	●						●	
V16	V16GS W117T430 R		11	1.17	4.3	5.6	10.2	0.05	16	●	●
	V16GS W142T430 R		1.42	●						●	
	V16GS W157T430 R		1.57	●						●	
	V16GS W198T430 R		1.98	●						●	
	V16GS W200T430 R		2.00	●						●	
	V16GS W238T430 R		2.38	●						●	
	V16GS W300T430 R		3.00	●						●	
	V16GS W318T430 R		3.18	●						●	
	V16GS W350T430 R		3.50	●						●	
V16GS W400T430 R		4.00	●	●							

● In stock ○ Available upon request

ТОВ «СМАРТТЕК ІНЖИНІРИНГ», Т. +380-50-396-90-96, info@smarttec.com.ua, https://www.smarttec.com.ua



Square Grooving

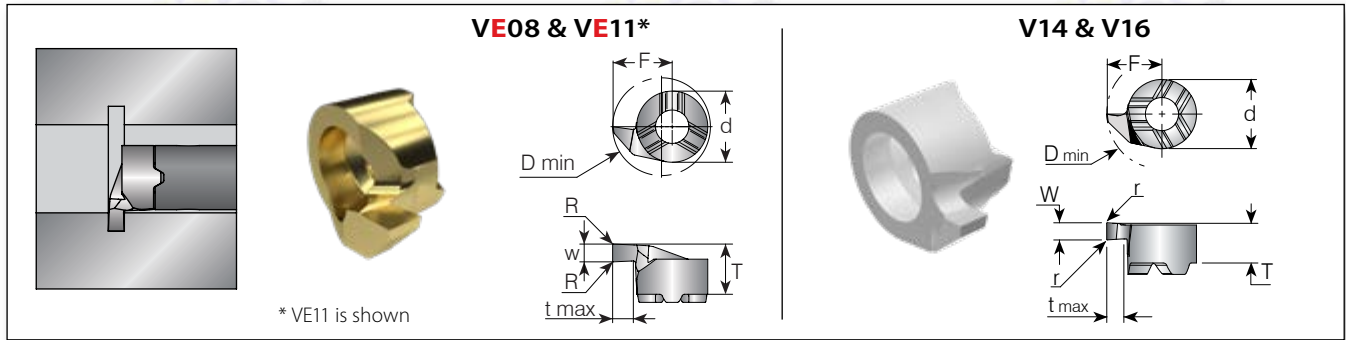

* VE11 is shown

VE08 & VE11 | Mini-VE

Insert Style	Ordering Code	Dimensions mm						Min. Bore Dia.	Grade
	RH/LH	d	W ^{+0.03}	t max	T	F	r	D min	VTX
VE08	VE08020GS W150T100R/L	6	1.50	1.00	4.4	4.8	0.20	8	•
	VE08064GS W186T146R/L		1.86	1.46			0.64		○
	VE08020GS W198T100R/L		1.98	1.00			0.20		○
VE11	VE11020GS W070T180R/L	8	0.70	1.80	5.7	6.7	0.20	11	○
	VE11020GS W117T230R/L		1.17	2.30			0.20		○
	VE11020GS W200T230R/L		2.00	2.30			0.20		○

• In stock ○ Available upon request

V14 & V16

Insert Style	Ordering Code	Dimensions mm						Min. Bore Dia.	Grades	
	RH	d	W ^{+0.03}	t max	T	F	r	D min	VBX	VTX
V14	V14GSR W078T400 R	9	0.78	4.0	5.6	9.0	0.2	14	•	•
	V14GSR W117T400 R		1.17						•	•
	V14GSR W150T400 R		1.50						•	•
	V14GSR W157T400 R		1.57						•	•
	V14GSR W198T400 R		1.98						•	•
	V14GSR W200T400 R		2.00						•	•
	V14GSR W238T400 R		2.38						•	•
	V14GSR W318T400 R		3.18						•	•
V16	V16GSR W117T430 R	11	1.17	4.3	5.6	10.2	0.2	16	•	•
	V16GSR W157T430 R		1.57						•	•
	V16GSR W198T430 R		1.98						•	•
	V16GSR W238T430 R		2.38						•	•
	V16GSR W318T430 R		3.18						•	•

• In stock ○ Available upon request



Round Grooving - DIN 7993

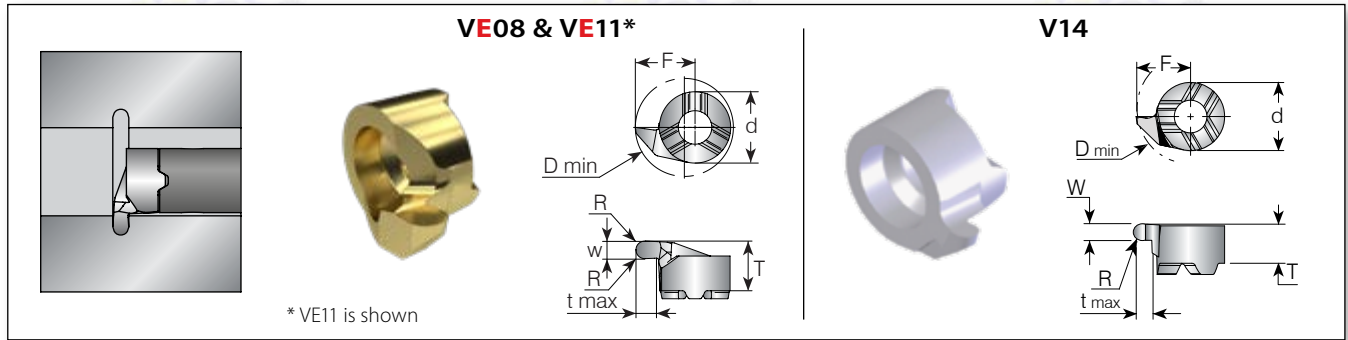

VE08 & VE11 | Mini-VE

Insert Style	Ordering Code	Dimensions mm						Min. Bore Dia.	Grade	
		RH/LH	d	W ^{+0.03}	t max	T	F			r
VE08	VE08040GR W080T100R/L			0.800				0.400	8	•
	VE08060GR W120T100R/L			1.200				0.600		○
	VE08080GR W160T100R/L		6	1.600	1.0	4.4	4.8	0.800		○
	VE08090GR W180T100R/L			1.800				0.900		○
	VE08100GR W200T100R/L			2.000				1.000		•
VE11	VE11028GR W057T200R/L			0.577	2.0			0.287	11	○
	VE11030GR W060T170R/L			0.600	1.7			0.300		○
	VE11040GR W080T230R/L			0.800	2.3			0.400		•
	VE11060GR W120T230R/L		8	1.200	2.3	5.7	6.7	0.600		○
	VE11078GR W157T230R/L			1.570	2.3			0.785		○
	VE11100GR W200T230R/L			2.000	2.3			1.000		•
	VE11120GR W240T230R/L			2.400	2.3			1.200		○

• In stock ○ Available upon request

V14

Insert Style	Ordering Code	Dimensions mm						Min. Bore Dia.	Grades		
		RH	d	W ^{+0.03}	t max	T	F		r	VBX	VTX
V14	V14D7993 W120T400 R			1.20				0.6	14	•	•
	V14D7993 W157T400 R			1.57				0.785		•	•
	V14D7993 W180T400 R			1.80				0.9		•	•
	V14D7993 W200T400 R			2.00				1.0		•	•
	V14D7993 W220T400 R		9	2.20	4.0	5.6	9.0	1.1		•	•
	V14D7993 W238T400 R			2.38				1.19		•	•
	V14D7993 W300T400 R			3.00				1.5		•	•
	V14D7993 W318T400 R			3.18				1.59		•	•

• In stock ○ Available upon request

ТОВ «СМАРТТЕК ІНЖИНІРИНГ», Т. +380-50-396-90-96, info@smarttec.com.ua, https://www.smarttec.com.ua

Square Face Grooving



V14

Insert Style	Ordering Code	Dimensions mm						Min. Bore Dia.	Grades	
		d	W ^{+0.03}	t max	T	F	r		VBX	VTX
V14	RH	9	1.00	1.5	7.7	9	0.2	14	•	○
	V14FGW100T150 R								•	○
	V14FGW150T250 R								•	○
	V14FGW200T300 R								•	○
	V14FGW200T500 R								•	○
	V14FGW250T300 R								•	○
	V14FGW250T500 R								•	○
V14FGW300T300 R	•	○								

• In stock ○ Available upon request

Square Face Grooving



V14

Insert Style	Ordering Code	Dimensions mm						Min. Bore Dia.	Grades	
		d	W ^{+0.03}	t max	T	F	r		VBX	VTX
V14	RH	9	1.00	1.5	7.3	9	0.2	12	•	○
	V14FEGW100T150 R								•	○
	V14FEGW150T250 R								•	○
	V14FEGW200T300 R								•	○
	V14FEGW200T500 R								•	○
	V14FEGW250T300 R								•	○
	V14FEGW250T500 R								•	○
V14FEGW300T300 R	•	○								

• In stock ○ Available upon request

Round Face Grooving



V14

Insert Style	Ordering Code	Dimensions mm						Min. Bore Dia.		Grades	
		RH	d	W ^{+0.03}	t max	T	F	r	D min	VBX	VTX
V14	V14FGR050T150 R		9	1.00	1.5	7.7	9	0.5	14	•	◦
	V14FGR100T300 R		9	2.00	3	9.2	9	1.0	14	•	◦
	V14FGR150T300 R		9	3.00	3	9.2	9	1.5	14	•	◦

• In stock ◦ Available upon request

Round Face Grooving



V14

Insert Style	Ordering Code	Dimensions mm						Min. Bore Dia.		Grades	
		RH	d	W ^{+0.03}	t max	T	F	r	D min	VBX	VTX
V14	V14FEGR100T500 R		9	2.00	5	10.7	9	1.00	12	•	◦
	V14FEGR125T500 R		9	2.50	5	10.7	9	1.25	12	•	◦

• In stock ◦ Available upon request

Threading

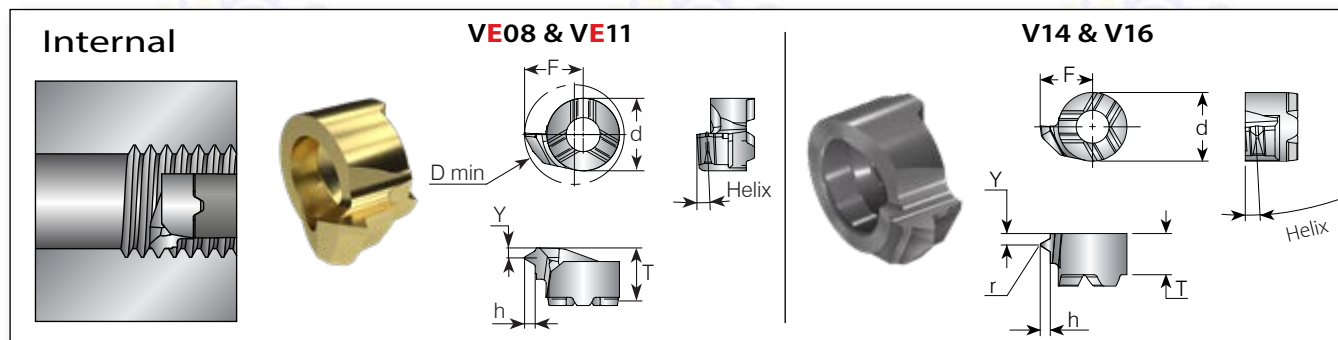

Partial Profile 60° | Mini-VE

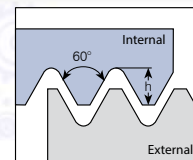

Insert Style	Pitch		Ordering Code	Dimensions mm						Helix		Grade	
	TPI	mm		RH/LH	d	T	F	Y	r	h max	Deg.	VTX	
VE08	48-32	0.5-0.75	VE08TH H60R/L	6	4.6	4.20	0.5	0.025	0.49	1.5	o		
	24-20	1.0-1.25	VE08TH I60R/L			4.46	0.8	0.095	0.74	2.5	o		
	16-14	1.5-1.75	VE08TH J60R/L			4.76	0.9	0.137	1.04	3	o		
VE11	48-32	0.5-0.75	VE11TH H60R/L	8	5.8	5.80	0.5	0.025	0.49	1.5	o		
	24-20	1.0-1.25	VE11TH I60R/L			6.06	0.8	0.095	0.74	1.5	o		
	16-14	1.5-1.75	VE11TH J60R/L			5.61	0.9	0.137	1.04	3	o		

• In stock ◦ Available upon request

Partial Profile 60° - V14 & V16

Insert Style	Pitch		Ordering Code	Dimensions mm						Helix		Grades	
	TPI	mm		RH	d	T	F	Y	r	h max	Deg.	VBX	VTX
V14	48-16	0.5-1.5	V14TH A60 R	9	5.7	9	0.9	0.05	1.485	1.5	•	•	
	14-8	1.75-3.0	V14TH G60 R				1.7	0.16	2.350		•	•	
	48-8	0.5-3.0	V14TH AG60 R				1.7	0.05	2.350		•	•	
V16	48-16	0.5-1.5	V16TH A60 R	11	5.7	10.2	0.9	0.05	1.485	1.5	•	•	
	14-8	1.75-3.0	V16TH G60 R				1.7	0.16	2.835		•	•	
	48-8	0.5-3.0	V16TH AG60 R				1.7	0.05	2.835		•	•	

• In stock ◦ Available upon request

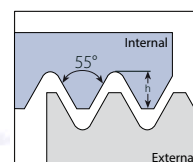

Partial Profile 55°

Insert Style	Pitch		Ordering Code	Dimensions mm						Helix		Grades	
	TPI	mm		RH	d	T	F	Y	r	h max	Deg.	VBX	VTX
V14	48-16	0.5-1.5	V14TH A55 R	9	5.7	9	0.9	0.05	1.71	1.5	•	•	
	14-8	1.75-3.0	V14TH G55 R				1.7	0.21	2.700		•	•	
	48-8	0.5-3.0	V14TH AG55 R				1.7	0.07	2.700		•	•	
V16	48-16	0.5-1.5	V16TH A55 R	11	5.7	10.2	0.9	0.07	1.71	1.5	•	•	
	14-8	1.75-3.0	V16TH G55 R				1.7	0.25	3.236		•	•	
	48-8	0.5-3.0	V16TH AG55 R				1.7	0.07	3.236		•	•	

• In stock ◦ Available upon request

Threading

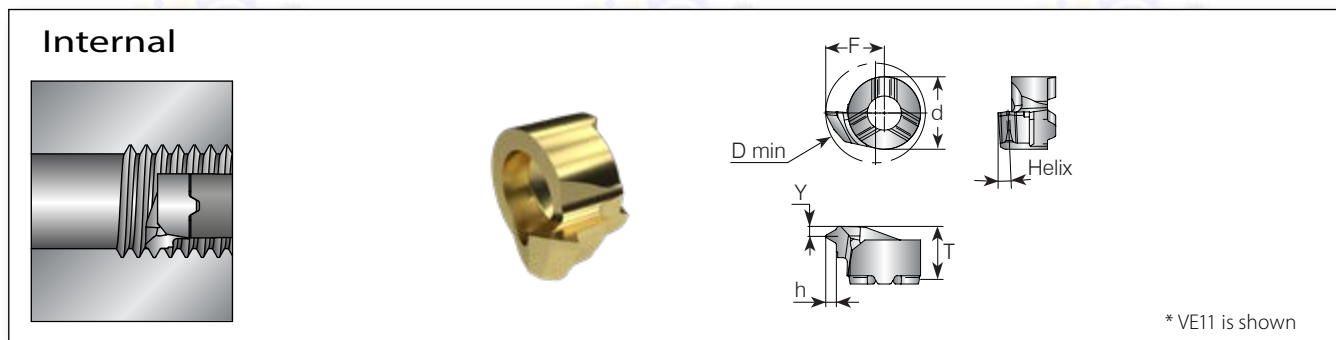

* VE11 is shown

ISO Metric | Mini-VE

Defined by: R262 (DIN 13)
Tolerance class: 6g/6H

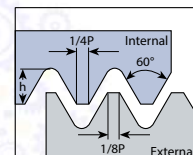

Min Thread	Insert Style	Ordering Code	Dimensions mm					Helix	Grade		
			mm	RH/LH	d	T	F			Y	h min
M8x.5	VE08	VE08TH .50ISOR/L	0.50		6	4.6	3.86	0.35	0.29	1.0	o
M8.5x.75		VE08TH .75ISOR/L	0.75				4.19	0.50	0.43	1.5	o
M9x1.0		VE08TH 1.00ISOR/L	1.00				4.29	0.50	0.58	2.0	o
M10x1.25		VE08TH 1.25ISOR/L	1.25				4.44	0.80	0.72	2.5	o
M10x1.5		VE08TH 1.50ISOR/L	1.50				4.58	0.90	0.87	3.0	o
M12x1.75		VE08TH 1.75ISOR/L	1.75				4.80	0.90	1.01	3.0	o
M14x2.0	VE11	VE11TH 2.00ISOR/L	2.00		8	5.85	6.47	1.10	1.15	2.5	o

- In stock
- Available upon request

American UN | Mini-VE

Defined by: ANSI B1.1:74
Tolerance class: 2A/2B

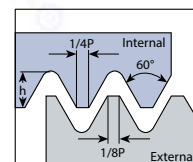

Min Thread	Insert Style	Ordering Code	Dimensions mm					Helix	Grade		
			TPI	RH/LH	d	T	F			Y	h min
3/8"-32UNEF	VE08	VE08TH 32UNR/L	32		6	4.6	4.21	0.50	0.46	1.5	o
3/8"-28UN		VE08TH 28UNR/L	28				4.28	0.50	0.52	2	o
3/8"-24UNF		VE08TH 24UNR/L	24				4.32	0.65	0.61	2	o
3/8"-20UN		VE08TH 20UNR/L	20				4.45	0.80	0.73	2.5	o
3/8"-18UNS		VE08TH 18UNR/L	18				4.53	0.85	0.81	2.5	o
3/8"-16UNC		VE08TH 16UNR/L	16				4.33	0.95	0.92	2.5	o
7/16"-14UNC		VE08TH 14UNR/L	14				4.78	1.10	1.05	3	o
9/16"-12UNC	VE11	VE11TH 12UNR/L	12		8	5.85	6.44	1.24	1.22	2.5	o

- In stock
- Available upon request

Whitworth - BSW, BSP, BSF, BSB | Mini-VE

Defined by: B.S.84:1956, DIN 259,
ISO228/1:1982
Tolerance class: Medium Class A

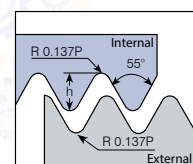

Min Thread	Insert Style	Ordering Code	Dimensions mm					Helix	Grade		
			TPI	RH/LH	d	T	F			Y	h min
1/2"x19W	VE11	VE11TH 19WR/L	19		8	5.85	6.18	0.85	0.86	2	o

- In stock
- Available upon request

Threading

Internal

* VE11 is shown

BSPT | Mini-VE - New Geometry

Defined by: B.S.21:1985
Tolerance class: Standard BSPT

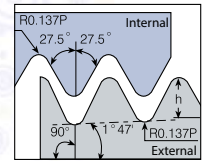

Min Thread	Insert Style	Ordering Code		Dimensions mm					Helix		VTX
	TPI	RH/LH	d	T	F	Y	h min	Deg.			
1/4"-19BSPT	VE11	19	VE11TH 19BSPTR/L	8	5.65	6.18	0.85	0.86	2	o	

- In stock ◦ Available upon request

NPT | Mini-VE - New Geometry

Defined by: USAS B2.1:1968
Tolerance class: Standard NPT

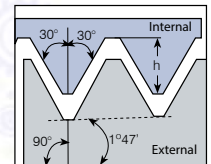

Min Thread	Insert Style	Ordering Code		Dimensions mm					Helix	Grade
	TPI	RH/LH	d	T	F	Y	h min	Deg.	VTX	
1/8"-27NPT	VE08	27	VE08TH 27NPTR/L	6	4.6	4.35	0.6	0.64	2	o
1/4"-18NPT		18	VE08TH 18NPTR/L			4.80	0.9	1.00	2	o

- In stock ◦ Available upon request

NPTF

Defined by: ANSI 1.2.3-1976
Tolerance class: Standard NPTF

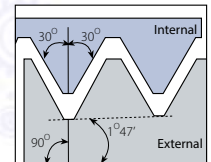

Min Thread	Insert Style	Ordering Code		Dimensions mm					Helix	Grades	
	TPI	RH	d	T	F	Y	h min	Deg.	VBX	VTX	
1/4"-18NPTF	V08	18	V08TH 18NPTF R	6	3.8	4.64	0.9	1.0	2	•	•

- In stock ◦ Available upon request

Trapez | Mini-VE - New Geometry

Defined by: DIN 103
Tolerance class: 7e/7H

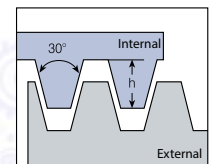

Min Thread	Insert Style	Ordering Code		Dimensions mm					Helix	Grade
	mm	RH/LH	d	T	F	Y	h min	Deg.	VTX	
TR10x2.0	VE08	2	VE08TH 2.0TRR/L	6	4.6	4.79	0.90	1.25	3.5	o
TR11x3.0		3	VE08TH 3.0TRR/L			4.95	1.18	1.75	5	o
TR16x4.0	VE11	4	VE11TH 4.0TRR/L	8	5.85	6.53	1.60	2.25	5	o

- In stock ◦ Available upon request



Mini-V Holders

Alloy Steel Shank.....	136
Reinforced Alloy Steel Shank.....	136
Carbide Shank.....	137
Reinforced Carbide Shank.....	138
Carbide Shank for Sleeves.....	138
V-CAP Holders NEW	139
Micro Holders for Carbide Shank Sleeve Clamping.....	139



Mini-V Holders - Ordering Code System

C	V	08	-	12	21	-
1	2	3		4	5	6

1 - Holder Type C - Carbide Shank None - Steel Shank	2 - Product Line VE - Mini-V Improved Toolholders (sizes 08 & 11) V - Mini-V Toolholders (sizes 14 & 16)	3 - Insert Size 08, 11, 14, 16	4 - Shank Diameter 6, 8, 12, 16
---	---	--	---

5 - Tool Overhang 12, 21, 29, 30, 42, 50, 56, 64, 80	6 - RH or LH None - RH L - LH
---	--

Mini-V Sleeves

MH	C	16	-	6
1	2	3		4

V-CAP Sleeve

MH	C	3	-	8	-	C4
1	2	S		5		6

1 - Holder Type MH - Microscope Holder	2 - Coolant C - Coolant Channels	3 - V-CAP System S - V-CAP System	4 - Shank Diameter 12, 16, 20	5 - Sleeve Bore Dia. 6, 8
--	--	---	---	-------------------------------------

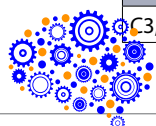

6 - V-CAP polygon Size C3, C4

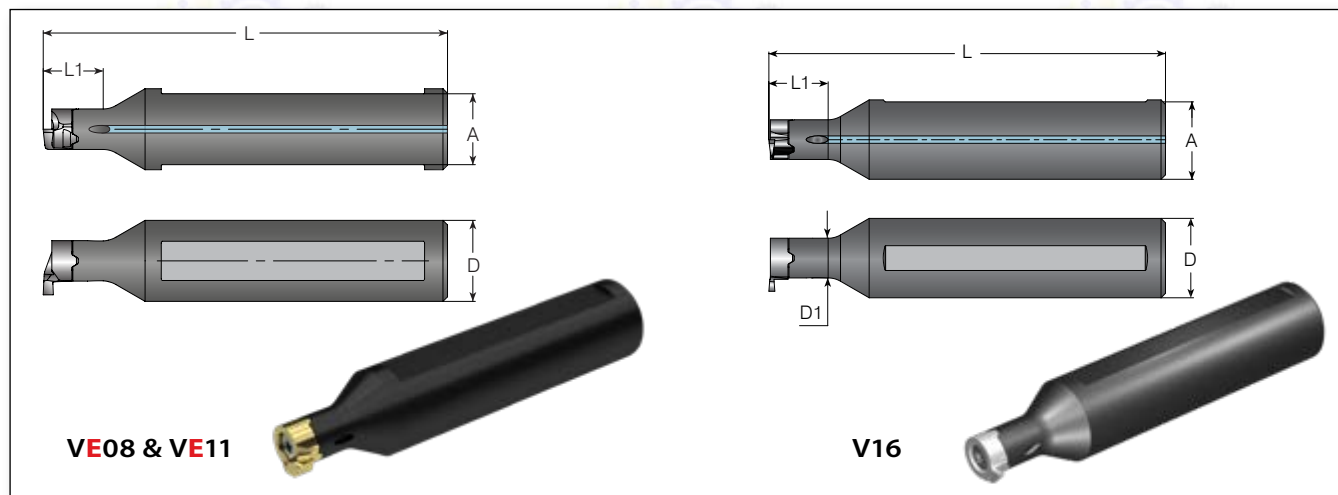

Alloy Steel Shank





Alloy Steel Shank | Mini-VE - New Geometry

Insert Style	Ordering Code	Dimensions mm					Spare Parts	
		A	L	L1	D	D1		
VE08	VE08-1612	14.6	80	12	16	6	SNV08	K2T
VE11	VE11-1612	14.6	80	12	16	8	SNV11	K3T

* Tightening Torque: 1.6 Nm.

Alloy Steel Shank - V16



Insert Style	Ordering Code	Dimensions mm					Spare Parts	
		A	L	L1	D	D1		
V16	V16-1622	15	100	22	16	11	SNV16	K4T

* Tightening Torque: 5.0 Nm max.

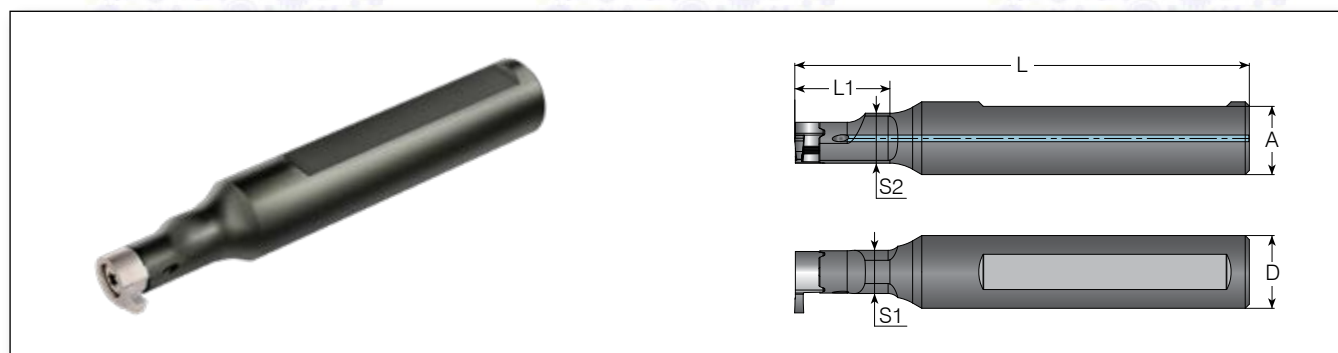
Reinforced Alloy Steel Shank



Reinforced Alloy Steel Shank - V14

Insert Style	Ordering Code	Dimensions mm						Spare Parts	
		A	L	L1	D	S1	S2		
V14	V14-1620	15.0	100	20	16	9.5	11	SNV14	KT15

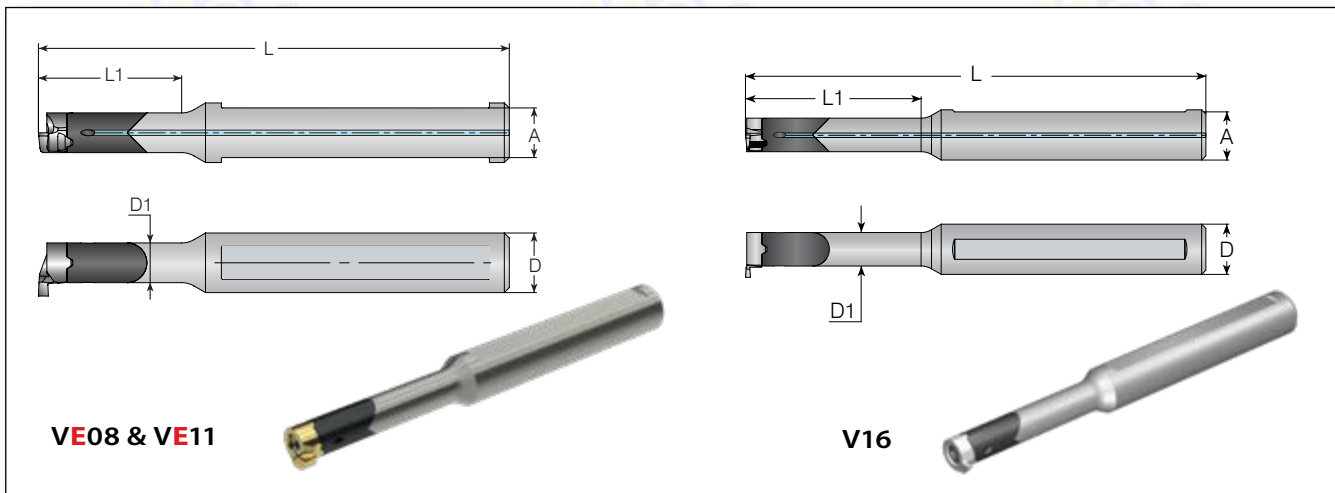

* Tightening Torque: 2.8 Nm max.

Carbide Shank



Carbide Shank | Mini-VE - New Geometry



Spare Parts

Insert Style		Dimensions mm						
		A	L	L1	D	D1	Screw*	Key
VE08	CVE08-1221	10.0	80.5	21	12	6	SNV08	K2T
	CVE08-1230		90.5	30				
	CVE08-1242		100	42				
	CVE08-1250		115	50				
VE11	CVE11-1229	10.0	95	29	12	8	SNV11	K3T
	CVE11-1242		110	42				
	CVE11-1256		120	56				
	CVE11-1264		130	64				

* Tightening Torque: VE08 - 1.6 Nm | VE11 - 2.2 Nm.

Carbide Shank - V16

Spare Parts



Insert Style		Dimensions mm						
Holder RH		A	L	L1	D	D1	Screw*	Key
V16	CV16-1240	11.0	130	40	12	11	SNV16	K4T
	CV16-1256		130	56				
	CV16-1280		150	80				

* Tightening Torque: 5.0 Nm max.

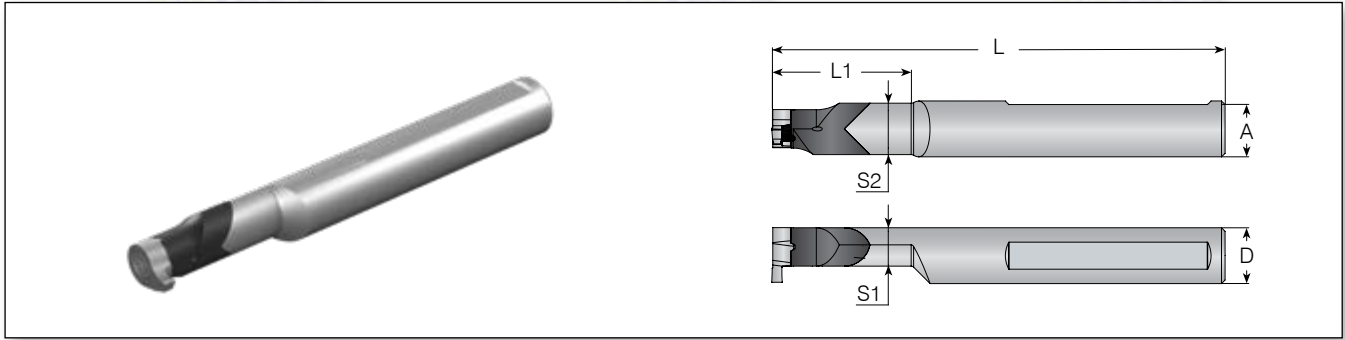
Reinforced Carbide Shank



Reinforced Carbide Shank - V14 & V16

Reinforced Carbide Shank - V14 & V16								Spare Parts	
Insert Style	Ordering Code	Dimensions mm							
	Holder RH	A	L	L1	D	S1	S2	Screw*	Key
V14	CV14-1234	11	100	34	12	9.3	11.9	SNV14	KT15
	CV14-1245**		110	45					
	CV14-1264**		130	64					
	CV14-1634	15	100	34	16	9.3	12.45		
	CV14-1645**		110	45					
	CV14-1664**		130	64					
CV14-1675**	145	75							
V16	CV16-1640	15	129.7	39.7	16	11	14.75	SNV16	K4T
	CV16-1656**		129.7	55.7					
	CV16-1680**		149.7	79.7					



* Tightening Torque: V14 - 2.8 Nm max. | V16 - 5.0 Nm max.

** For boring, chamfering and face grooving only.

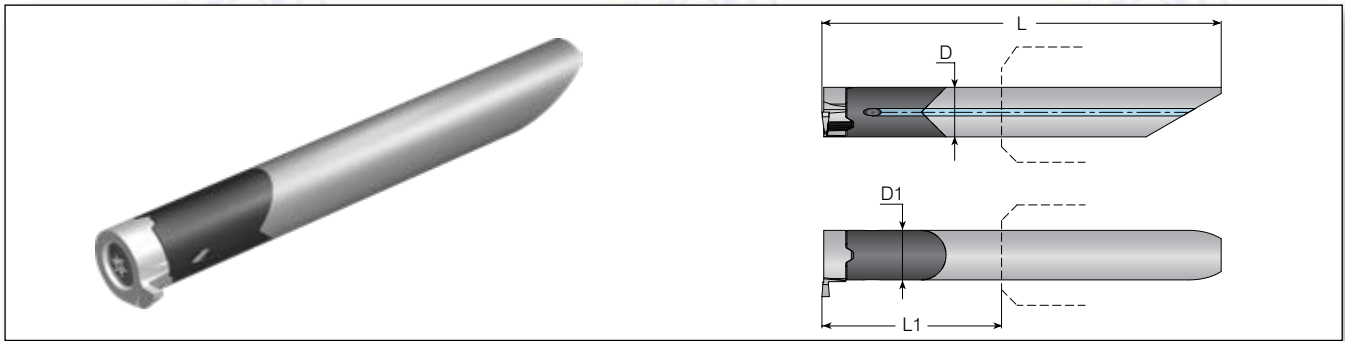
Carbide Shank for Sleeves



Carbide Shank for Sleeves - V08 & V11

Carbide Shank for Sleeves - V08 & V11								Spare Parts		
Insert Style	Ordering Code	Dimensions mm						Ordering Code		
	Holder RH	A	L	L1	D	D1	Sleeve	Screw*	Key	
V08	CV08-0621	-	45	21	6	6	MHC...-6	SNV08	K2T	
	CV08-0630**	-	54	30						
V11	CV11-0829	-	64.5	29	8	8	MHC...-8	SNV11	K3T	
	CV11-0842**	-	77.5	42						

* Tightening Torque: V08 - 0.65 Nm max. | V11 - 2.0 Nm max.

** For boring and chamfering only.

V-CAP Holders for Carbide Shank Sleeve Clamping

NEW

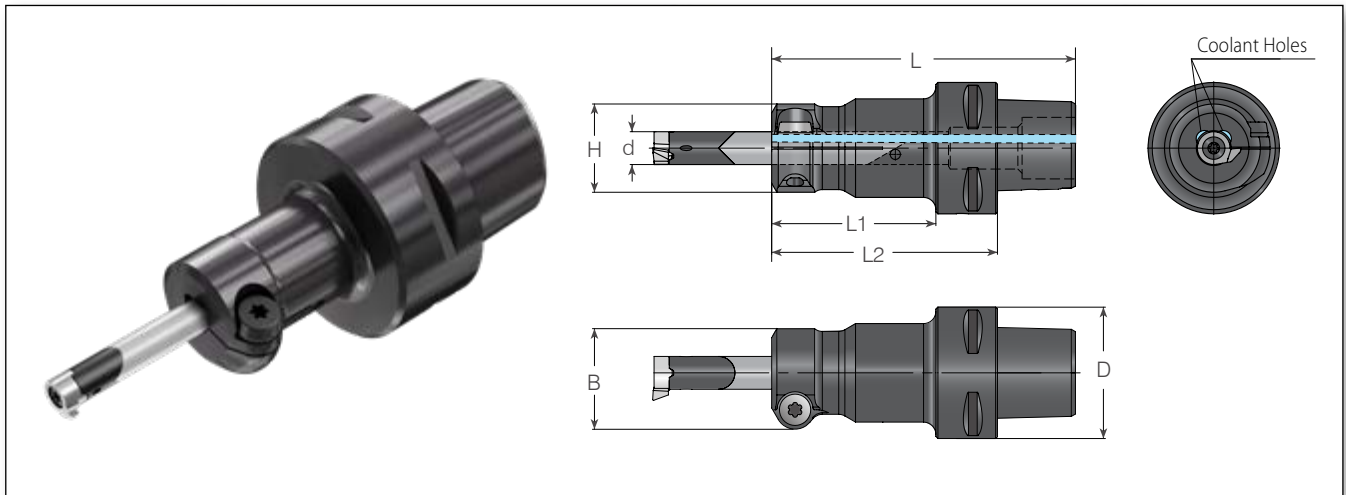

Micro Insert Dia.	Ordering Code	Dimensions mm						Spare Parts	
		D	B	H	L1	L2	L		
6.0	MHCS-6-C3	32.0	23.7	20.0	30.0	45.0	64.0	SM5X10-15IPX2**	L15IP / LX15IP
	MHCS-6-C4	40.0	23.7	20.0	30.0	50.0	74.0		
8.0	MHCS-8-C3	32.0	24.5	21.5	40.0	55.0	74.0		
	MHCS-8-C4	40.0	24.5	21.5	40.0	60.0	84.0		

V-CAP holders are according to ISO 26623.

* Tightening Torque: 7 Nm max.

** SM5X10-15IPX2 is a special, double-sided screw. For an alternative screw, please use MS5X10 (key: S4).

Micro Holders for Carbide Shank Sleeve Clamping

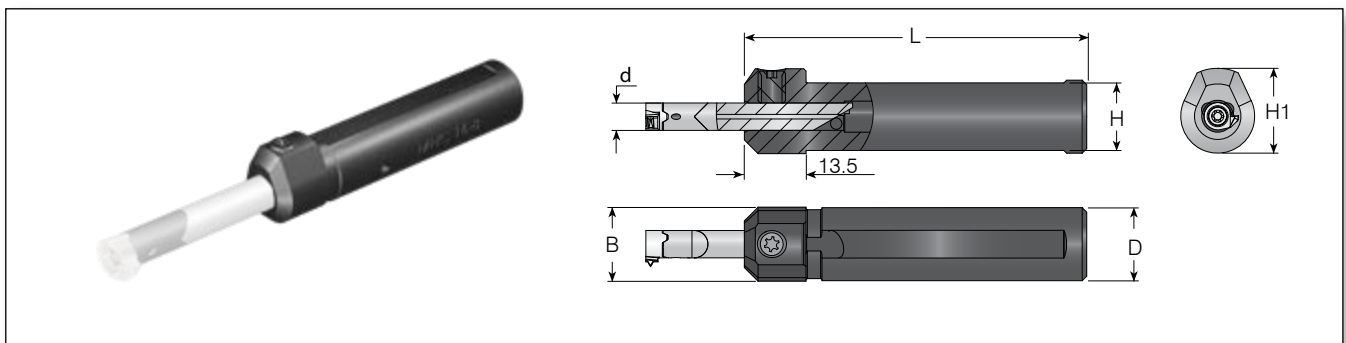

d	Ordering Code	Dimensions mm				Spare Parts	
		D=B	H1	H	L		
6	MHC 12-6	12	16	10.8	70	SL7DT15	KT15
	MHC 16-6	16	18.6	14.8	75		
	MHC 20-6	20	22	18.8	84		
8	MHC 16-8	16	18.6	14.8	100		
	MHC 20-8	20	22	18.8	103.5		

* Tightening Torque: 2.8 Nm max.

ТОВ «СМАРТТЕК ІНЖИНІРИНГ», Т. +380-50-396-90-96, info@smarttec.com.ua, https://www.smarttec.com.ua



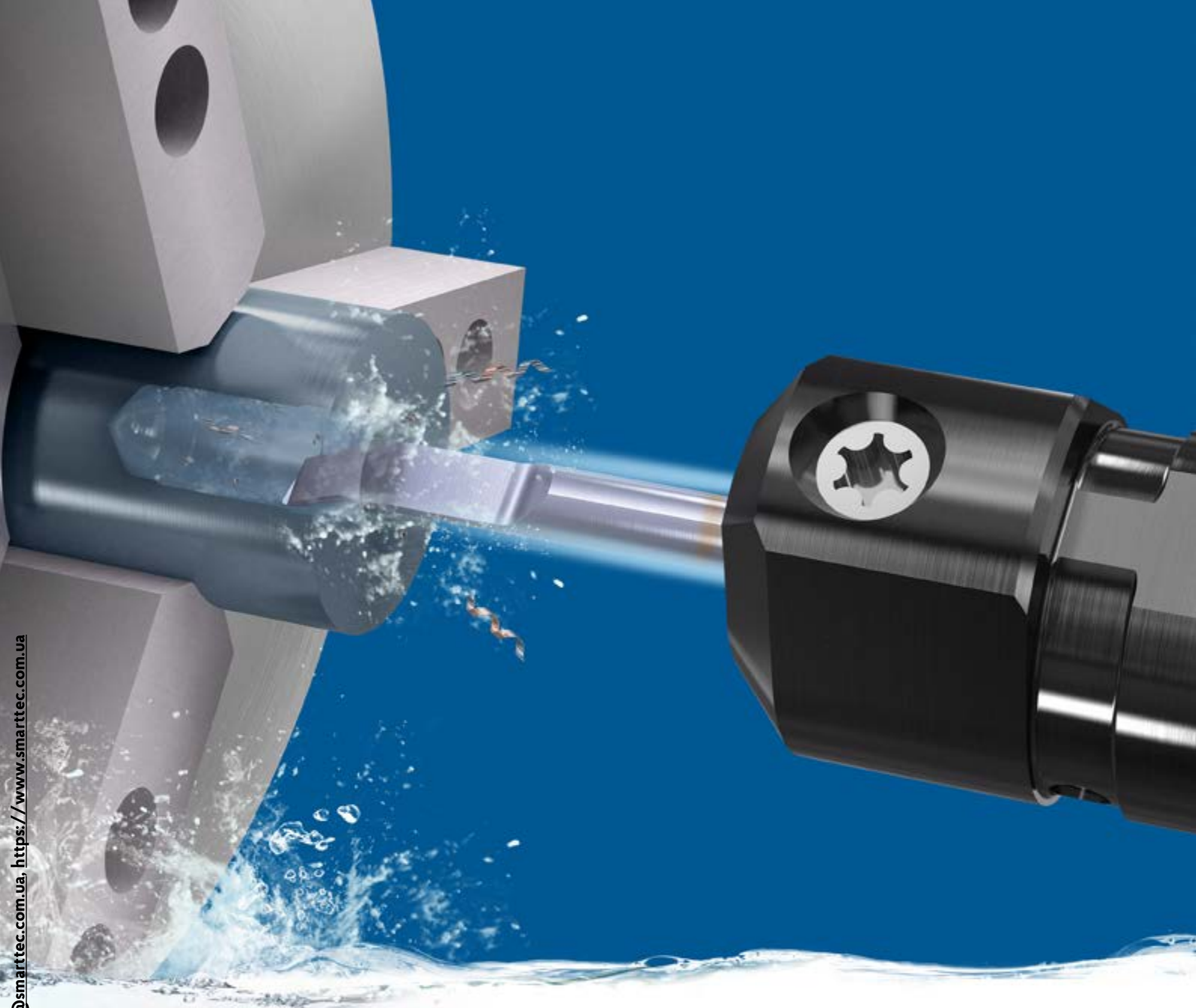

ТОВ «СМАРТТЕК ІНЖИНІРИНГ», Т. +380-50-396-90-96, info@smarttec.com.ua, <https://www.smarttec.com.ua>

INTERNAL GROOVE TURNING | **FINISHING**

microscope

Precise Turning, Grooving, Threading
& Face Grooving

microscope

Micro Tools for Small Bores

The **Microscope** line offers new and improved solutions for micro boring, grooving, chamfering and threading in bores as small as 1.0 mm.

The **Microscope** line offers a large and extended range of single-ended inserts and a full range of toolholders with a simple clamping system.



Improved Coolant Thru

Two coolant holes for effective chip removal and cooling of cutting edge

Slanted Insert Design

Provides exact radial insert location for high repeatability

Simple Clamping System

Simple and fool-proof. The new clamping system uses one large screw to secure the insert in the holder

Stopper Pin

Provides precise cutting edge height and perfect axial location

Internal Tools with High Pressure Coolant Thru



Boring with Chip Breaker

Boring

Boring & Profiling

Boring with Chip Former

Square Grooving

Pre-Part Off

Miniature Toolholders



V-Cap Holder with Shrink Clamping

Shrink Toolholders

Round Toolholders without Shoulder

Double Sided Round Toolholders without Shoulder

ТОВ «СМАРТТЕК ІНЖИНІРИНГ», Т. +380-50-396-90-96, info@smarttec.com.ua, https://www.smarttec.com.ua



Applications

BORING

Pages 150 - 161

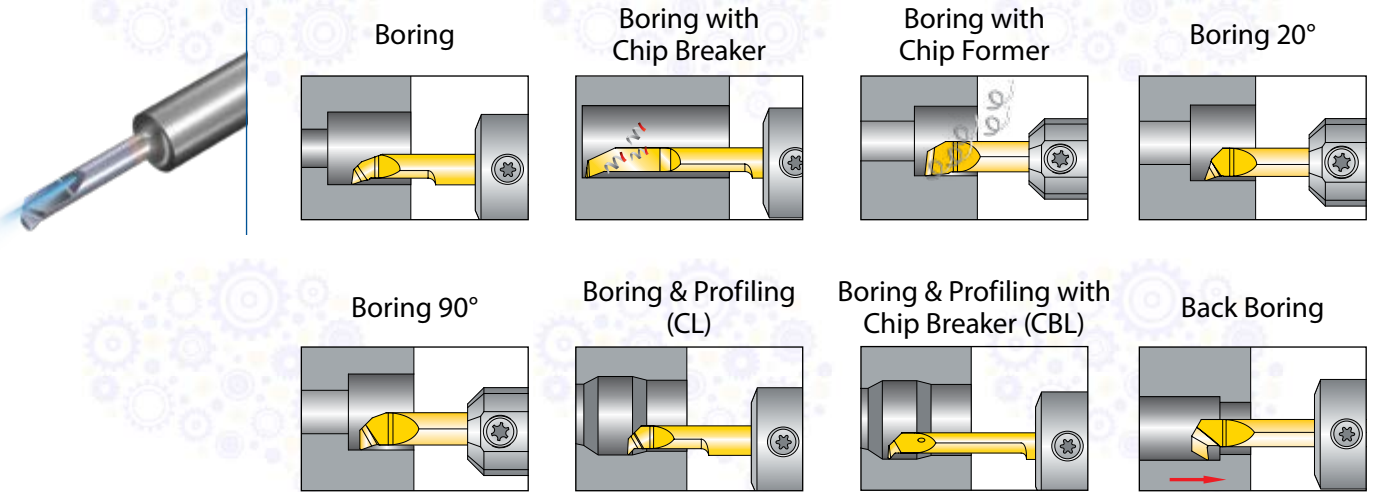

CHAMFERING

Page 161, 168

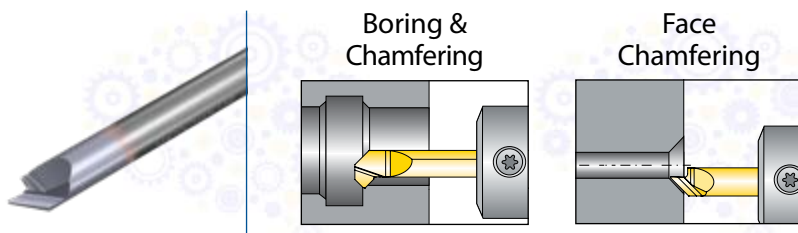

GROOVING

Pages 162 - 168

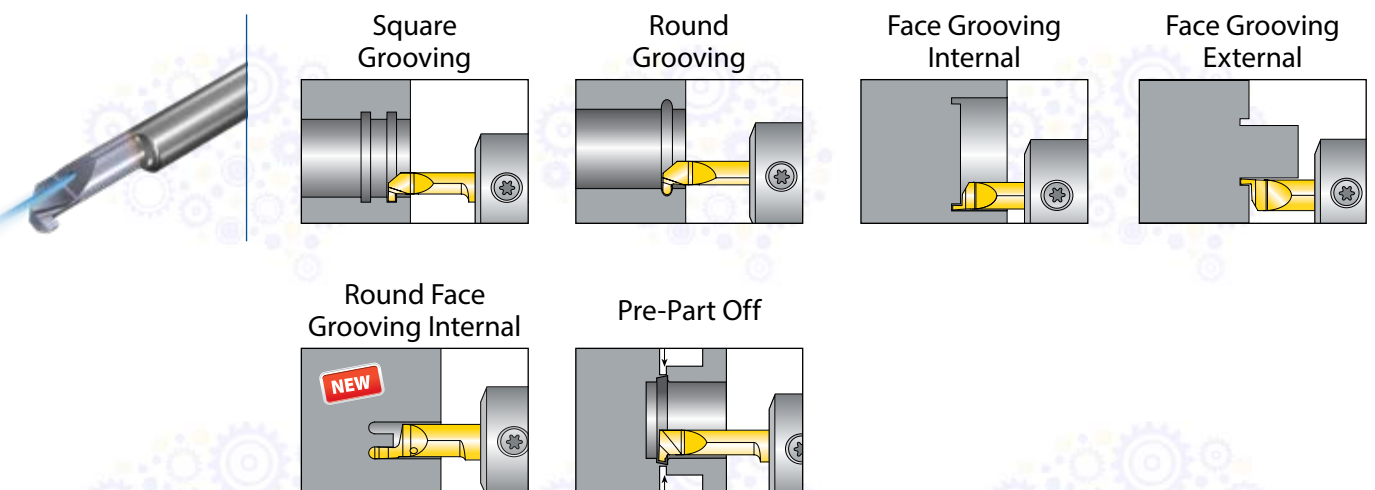

THREADING

Pages 169 - 171

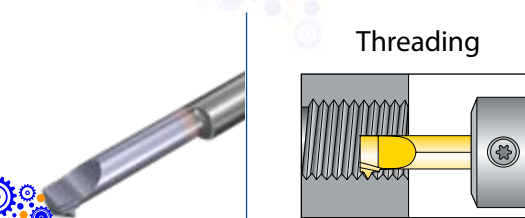

ТОВ «СМАРТТЕК ІНЖИНІРИНГ», Т. +380-50-396-90-96, info@smarttec.com.ua, https://www.smarttec.com.ua

Boring Technical Data

Recommended VBX Cutting Speeds Vc [m/min]

Material Group	Vargus No.	Material	Hardness Brinell HB	Vc[m/min] (Coated)
P Steel	1	Unalloyed Steel	Low Carbon (C=0.1-0.25%)	125
	2		Medium Carbon (C=0.25-0.55%)	150
	3		High Carbon (C=0.55-0.85%)	170
	4	Low Alloy Steel (alloying elements ≤5%)	Non Hardened	180
	5		Hardened	275
	6		Hardened	350
	7	High Alloy Steel (alloying elements >5%)	Annealed	200
	8		Hardened	325
	9	Cast Steel	Low Alloy (alloying elements <5%)	200
	10		High Alloy (alloying elements >5%)	225
M Stainless Steel	11	Stainless Steel Ferritic	Non Hardened	200
	12		Hardened	330
	13	Stainless Steel Austenitic	Austenitic	180
	14		Super Austenitic	200
	15	Stainless Steel Cast Ferritic	Non Hardened	200
	16		Hardened	330
	17	Stainless Steel Cast Austenitic	Austenitic	200
	18		Hardened	330
K Cast Iron	28	Malleable Cast Iron	Ferritic (short chips)	130
	29		Pearlitic (long chips)	230
	30	Grey Cast Iron	Low Tensile Strength	180
	31		High Tensile Strength	260
	32	Nodular SG Iron	Ferritic	160
	33		Pearlitic	260
N(K) Non-Ferrous Metals	34	Aluminum Alloys Wrought	Non Aging	60
	35		Aged	100
	36	Aluminum Alloys	Cast	75
	37		Cast & Aged	90
	38	Aluminum Alloys	Cast Si 13-22%	130
	39	Copper and Copper Alloys	Brass	90
	40		Bronze and non leaded Copper	100
	S(M) Heat Resistant Material	19	High Temperature Alloys	Annealed (Iron based)
20		Aged (Iron based)		280
21		Annealed (Nickel or Cobalt based)		250
22		Aged (Nickel or Cobalt based)		350
23		Titanium Alloys	Pure 99.5 Ti	400Rm
24			α+β Alloys	1050Rm
H(K) Hardened Material	25	Extra Hard Steel	Hardened & Tempered	45-50HRc
	26			51-55HRc

Carbide Grade



VBX - TiCN PVD coated
VTX - AlTiN PVD coated

VTX

Excellent for Boring applications in medium-to-high cutting speeds and in dry conditions.

Multilayered AlTiN PVD coated, general purpose grade for prevention of peeling and chipping.

* For **VTX Grade**, increase speed by 20%.

VBX

Excellent for all applications and outstanding wear resistance in low-to-medium cutting speeds, combined with good fracture toughness.

TiCN PVD coated.



Boring Technical Data

Boring and Profiling in Finishing Operations – Recommended Depth of Cut [a_p max. (mm)] and Feed f [mm/rev]

High Alloy Steel, 330 HB, 2100 Kc [N/mm ²]			
D min.	Vmax mm ²	a_p max. (mm)	f mm/rev
1 mm - 1.7 mm	0.0012	0.08	0.015
1.8 mm - 2.7mm	0.0017	0.10	0.017
2.8 mm - 3.2 mm	0.0031	0.18	0.017
3.3 mm - 3.7 mm	0.0040	0.22	0.018
3.8 mm - 4.2 mm	0.0050	0.25	0.020
4.3 mm - 5.2 mm	0.0084	0.30	0.028
5.2 mm - 6.2 mm	0.0150	0.30	0.050
6.3 mm - 7.2 mm	0.0210	0.35	0.060

Austenitic Stainless Steel, 200 HB, 2600 Kc [N/mm ²]			
D min.	Vmax mm ²	a_p max. (mm)	f mm/rev
1 mm - 1.7 mm	0.0009	0.06	0.015
1.8 mm - 2.7mm	0.0015	0.10	0.015
2.8 mm - 3.2 mm	0.0018	0.12	0.015
3.3 mm - 3.7 mm	0.0023	0.15	0.015
3.8 mm - 4.2 mm	0.0027	0.18	0.015
4.3 mm - 5.2 mm	0.0030	0.20	0.015
5.2 mm - 6.2 mm	0.0050	0.20	0.025
6.3 mm - 7.2 mm	0.0063	0.25	0.025

Machining Recommendation

- $V_{max} = \text{Feed mm/rev} \times a_p \text{ (mm)}$
- Exceeding the V_{max} value may cause corner excessive wear and breakage
- Recommendations listed are for average roughness of 0.5 (Ra)
- Lower Hardness and Lower Kc enable to increase the value of V_{max} , for higher metal removal
- Recommendations listed are for medium L1. Increase V_{max} value by using shorter L1 tools

When encountering chip flow evacuation problems, it is recommended to increase the distance between the workpiece and sleeve.

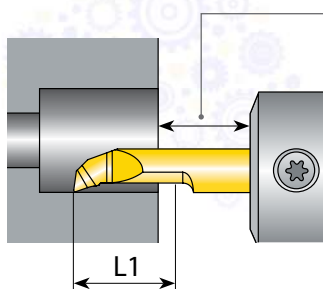

Grooving Technical Data

Recommended VBX Cutting Speeds Vc [m/min] and Feed f [mm/rev]

Material Group	Vargus No.	Material	Hardness Brinell HB	Vc[m/min] (Coated)	Feed f [mm/rev]	
P Steel	1	Unalloyed Steel	Low Carbon (C=0.1-0.25%)	125	50-120	0.05
	2		Medium Carbon (C=0.25-0.55%)	150	40-100	0.05
	3		High Carbon (C=0.55-0.85%)	170	30-80	0.05
	4	Low Alloy Steel (alloying elements ≤5%)	Non Hardened	180	50-70	0.05
	5		Hardened	275	40-60	0.05
	6		Hardened	350	30-50	0.05
	7	High Alloy Steel (alloying elements >5%)	Annealed	200	30-50	0.05
	8		Hardened	325	25-40	0.05
	9	Cast Steel	Low Alloy (alloying elements <5%)	200	30-50	0.05
	10		High Alloy (alloying elements >5%)	225	25-40	0.05
M Stainless Steel	11	Stainless Steel Ferritic	Non Hardened	200	60-100	0.05
	12		Hardened	330	40-60	0.05
	13	Stainless Steel Austenitic	Austenitic	180	50-90	0.05
	14		Super Austenitic	200	40-60	0.05
	15	Stainless Steel Cast Ferritic	Non Hardened	200	40-60	0.05
	16		Hardened	330	30-50	0.05
	17	Stainless Steel Cast Austenitic	Austenitic	200	40-60	0.05
	18		Hardened	330	30-50	0.05
K Cast Iron	28	Malleable Cast Iron	Ferritic (short chips)	130	50-70	0.04
	29		Pearlitic (long chips)	230	50-70	0.04
	30	Grey Cast Iron	Low Tensile Strength	180	50-70	0.04
	31		High Tensile Strength	260	40-60	0.04
	32	Nodular SG Iron	Ferritic	160	50-70	0.04
33	Pearlitic		260	60-80	0.04	
N(K) Non-Ferrous Metals	34	Aluminum Alloys Wrought	Non Aging	60	100-300	0.04
	35		Aged	100	100-150	0.04
	36	Aluminum Alloys	Cast	75	100-150	0.04
	37		Cast & Aged	90	60-100	0.04
	38	Aluminum Alloys	Cast Si 13-22%	130	100-150	0.04
	39	Copper and Copper Alloys	Brass	90	60-100	0.03
	40		Bronze and non leaded Copper	100	60-100	0.04
S(M) Heat Resistant Material	19	High Temperature Alloys	Annealed (Iron based)	200	25-45	0.02
	20		Aged (Iron based)	280	20-30	0.02
	21		Annealed (Nickel or Cobalt based)	250	15-20	0.02
	22		Aged (Nickel or Cobalt based)	350	10-15	0.02
	23	Titanium Alloys	Pure 99.5 Ti	400Rm	60-100	0.02
24	α+β Alloys		1050Rm	40-50	0.02	
H(K) Hardened Material	25	Extra Hard Steel	Hardened & Tempered	45-50HRc	20-40	0.02
	26			51-55HRc	20-35	0.02

Carbide Grade

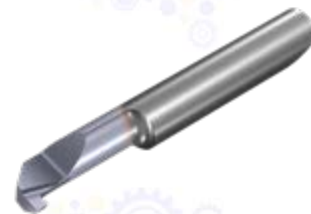

VBX - TiCN PVD coated
VTX - AlTiN PVD coated

Machining Recommendation

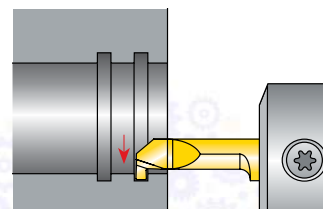

Machine the groove in one motion instead of intervals.

VTX

Excellent for Boring applications in medium-to-high cutting speeds and in dry conditions.

Multilayered AlTiN PVD coated, general purpose grade for prevention of peeling and chipping.

* For **VTX Grade**, increase speed by 20%.

VBX

Excellent for all applications and outstanding wear resistance in low-to-medium cutting speeds, combined with good fracture toughness.

TiCN PVD coated.

Threading Technical Data

Recommended VBX Cutting Speeds Vc [m/min]

Material Group	Vargus No.	Material	Hardness Brinell HB	Vc[m/min] (Coated)
P Steel	1	Unalloyed Steel	Low Carbon (C=0.1-0.25%)	125
	2		Medium Carbon (C=0.25-0.55%)	150
	3		High Carbon (C=0.55-0.85%)	170
	4	Low Alloy Steel (alloying elements ≤ 5%)	Non Hardened	180
	5		Hardened	275
	6		Hardened	350
	7	High Alloy Steel (alloying elements > 5%)	Annealed	200
	8		Hardened	325
	9	Cast Steel	Low Alloy (alloying elements < 5%)	200
	10		High Alloy (alloying elements > 5%)	225
M Stainless Steel	11	Stainless Steel Ferritic	Non Hardened	200
	12		Hardened	330
	13	Stainless Steel Austenitic	Austenitic	180
	14		Super Austenitic	200
	15	Stainless Steel Cast Ferritic	Non Hardened	200
	16		Hardened	330
	17	Stainless Steel Cast Austenitic	Austenitic	200
	18		Hardened	330
K Cast Iron	28	Malleable Cast Iron	Ferritic (short chips)	130
	29		Pearlitic (long chips)	230
	30	Grey Cast Iron	Low Tensile Strength	180
	31		High Tensile Strength	260
	32	Nodular SG Iron	Ferritic	160
	33		Pearlitic	260
N(K) Non-Ferrous Metals	34	Aluminum Alloys Wrought	Non Aging	60
	35		Aged	100
	36	Aluminum Alloys	Cast	75
	37		Cast & Aged	90
	38	Aluminum Alloys	Cast Si 13-22%	130
	39	Copper and Copper Alloys	Brass	90
	40		Bronze and non leaded Copper	100
	S(M) Heat Resistant Material	19	High Temperature Alloys	Annealed (Iron based)
20		Aged (Iron based)		280
21		Annealed (Nickel or Cobalt based)		250
22		Aged (Nickel or Cobalt based)		350
23		Titanium Alloys	Pure 99.5 Ti	400Rm
24	α+β Alloys		1050Rm	
H(K) Hardened Material	25	Extra Hard Steel	Hardened & Tempered	45-50HRc
	26			51-55HRc

Carbide Grade

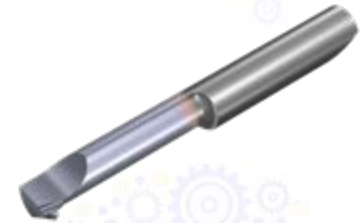

VBX - TiCN PVD coated
VTX - AlTiN PVD coated

Calculation of N [RPM]

$$N = \frac{1000 \times V_c}{\pi \times D}$$

$$V_c = \frac{N \times \pi \times D}{1000}$$

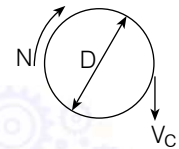

N - Revolution Per Minute [RPM]
V_c - Cutting Speed [m/mm]
D - Workpiece Diameter [mm]

Number of Passes for Threading

Pitch	mm	0.50	0.75	1.00	1.25	1.50	1.75	2.00
TPI		48	32	24	20	16	14	12
No. of Passes (Microscope)		6-9	6-11	6-12	8-14	9-15	11-18	11-18

VTX

Excellent for Boring applications in medium-to-high cutting speeds and in dry conditions. Multilayered AlTiN PVD coated, general purpose grade for prevention of peeling and chipping.

* For **VTX Grade**, increase speed by 20%.

VBX

Excellent for all applications and outstanding wear resistance in low-to-medium cutting speeds, combined with good fracture toughness. TiCN PVD coated.

microscope Inserts



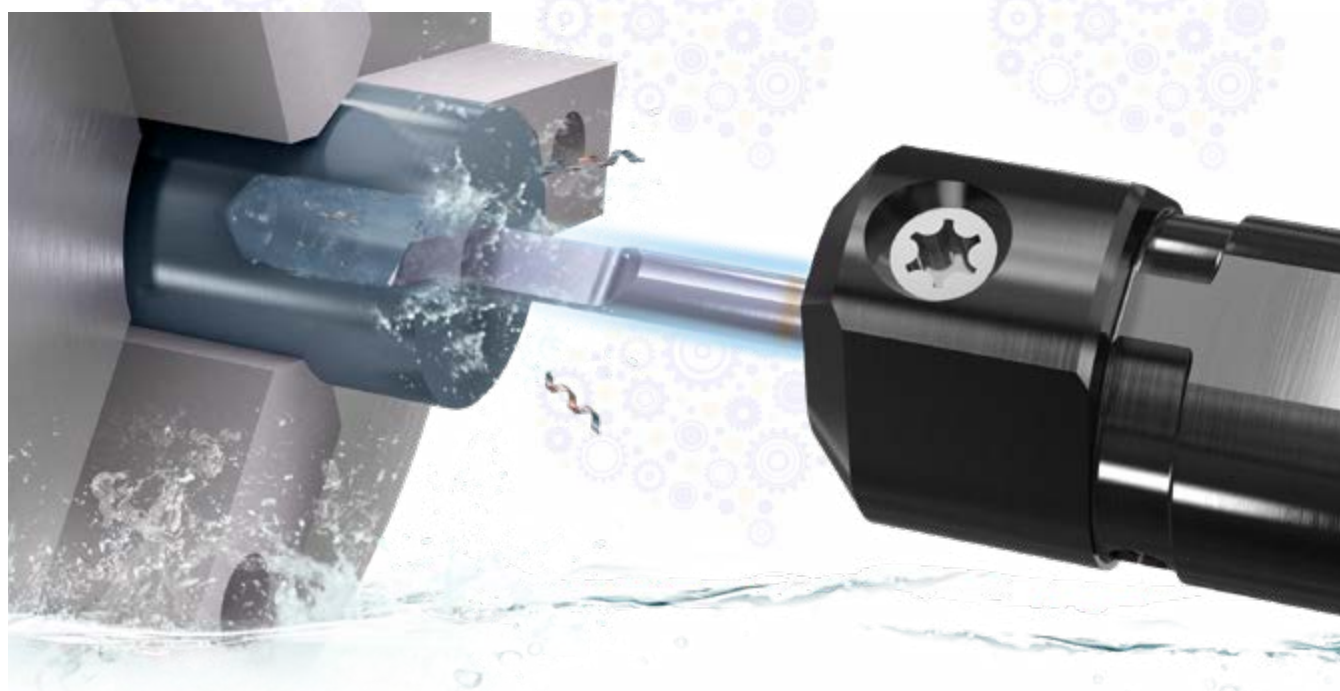











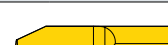

Boring with HPC.....	150
Boring.....	151
Boring with Chip Breaker and HPC.....	154
Boring with Chip Breaker.....	155
Boring with Chip Former and HPC.....	156
Boring with Chip Former.....	157
Boring 20°.....	158
Boring 90°.....	158
Boring & Profiling with Chip Breaker & HPC (CBLF) NEW	159
Boring & Profiling (CL) with HPC.....	160
Boring & Profiling (CL).....	160
Back Boring.....	161
Boring & Chamfering 45°.....	161
Square Grooving with HPC.....	162
Square Grooving.....	163
Round Grooving.....	165
Pre-Part Off.....	165
Face Grooving with HPC NEW	166
Face Grooving.....	167
Round Face Grooving with HPC NEW	168
Face Chamfering 45°.....	168
Threading.....	169

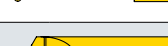

microscope Inserts - Ordering Code System

Boring:	M 1	4 2	42 3	BC 4	R05 5	- 6	L10 7	R 8	C 9	VTX 10
Grooving:	M 1	5 2	52 3	GS 4	W100 5	- 6	L10 7	R 8	C 9	VBX 10
Threading:	M 1	5 2	42 3	TH 4	0.5 5	ISO 6	L16 7	R/L 8	- 9	VBX 10

1 - Product Line
M/ MS / MN- Microscope MC - Microscope central location of cutting tip
2 - Shank Dia.
4, 5, 6, 7
3 - Min. Bore Dia. (mm)
1,7, 2,2, 3,2...

4 - Application Type
BC Boring 
BE Boring with Edge Prep 
B20 Boring 20° 
B90 Boring 90° 
CBLF Boring & Profiling with Chip Breaker 
CL Boring & Profiling 
BCB Boring with Chip Breaker 
BCF Boring with Chip Former 
BB Back Boring 
CH4545 Boring & Chamfering 45° 
CH45 Face Chamfering 45° 
GS Square Grooving 
GR Round Grooving 
FG Face Grooving Internal 
FP Face Grooving External 
PP Pre-Part Off 
RFG Round Face Grooving Internal 
TH Threading 

5 - Boring Nose Radius	
0.05, 0.1, 0.15, 0.2 (mm)	
5 - Grooving Width	
079 - 318 (mm)	
5 - Threading Pitch	
Full Profile - Pitch Range	
mm	TPI
0.5 - 1.5	28-18
Partial Profile - Pitch Range	
mm	TPI
A 0.5 - 1.5	A 48-16
F 0.5 - 1.0	F 48-24

6 - Threading Standard
A60 - Partial Profile 60° A55 - Partial Profile 55° ISO - ISO Metric UN - American UN NPT - NPT W - Whitworth for BSW, BSP TR - Trapez

7 - Maximum Length of Cut (mm)
L10 - 10mm, L15 - 15mm...

8 - RH or LH
R - RH L - LH

9 - Coolant
C - Internal Coolant NONE - Without Coolant

10 - Carbide Grade
VBX, VTX

ТОВ «СМАРТТЕК ІНЖИНІРИНГ», Т. +380-50-396-90-96, info@smarttec.com.ua, https://www.smarttec.com.ua

Boring with High Pressure Coolant

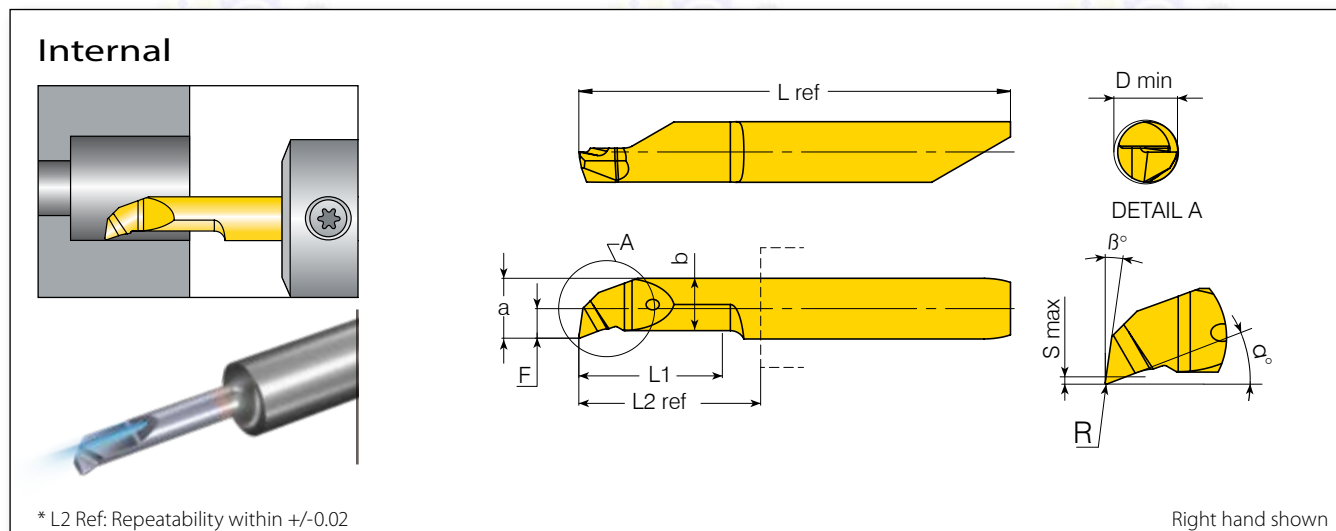

Shank Dia.	Min. Bore Dia.	Ordering Code	Dimensions mm								Grades				
d (mm)	D min. (mm)	RH/LH	L1	R	F	S max	a	b	α°	β°	L2 ref*	L ref	VBX	VTX	
4.0	3.0	M430BCR15L20RC**	20.0	0.15	1.36	0.2	2.7	2.36	17.5	8	22.8	39.8	◦	•	
	3.2	M432BCR15L10RC**	10.0	0.15	1.44	0.2	2.9	2.5	17.5	8	11.5	28.5	◦	•	
		M432BCR15L20RC**	20.0	0.15	1.4		2.87	2.45			22.8	39.8	◦	•	
	4.0	4.0	M440BCR20L10RC	10.0	0.20	1.90	0.25	3.74	3.35	17.5	8	11.5	28.5	◦	•
	4.2	4.2	M442BCR15L10RC**	10.0	0.15	1.93	0.3	3.93	3.13	19	8	11.5	28.5	◦	•
			M442BCR20L10RC**	10.0	0.20	1.98		3.98	3.13			11.5	28.5	◦	•
M442BCR15L21RC**			21.0	0.15	1.93	3.93		3.13	22.8			39.8	◦	•	
5.0	5.2	M552BCR20L10RC**	10.0	0.20	2.44	0.5	4.94	4.04	21	8	12.15	35	•	◦	
		M552BCR20L15RC	15.0	0.20	2.44		4.94	4.24			18.15	41	◦	•	
		M552BCR20L21RC**	21.0	0.20	2.44		4.94	4.04			23.15	46	◦	•	
		M552BCR20L30RC**	30.0	0.20	2.44		4.94	4.04			32.15	55	◦	•	
		M552BCR20L35RC**	35.0	0.20	2.44		4.94	4.04			37.15	60	◦	•	

** LH Tools are available upon request.

• In stock ◦ Available upon request

Boring

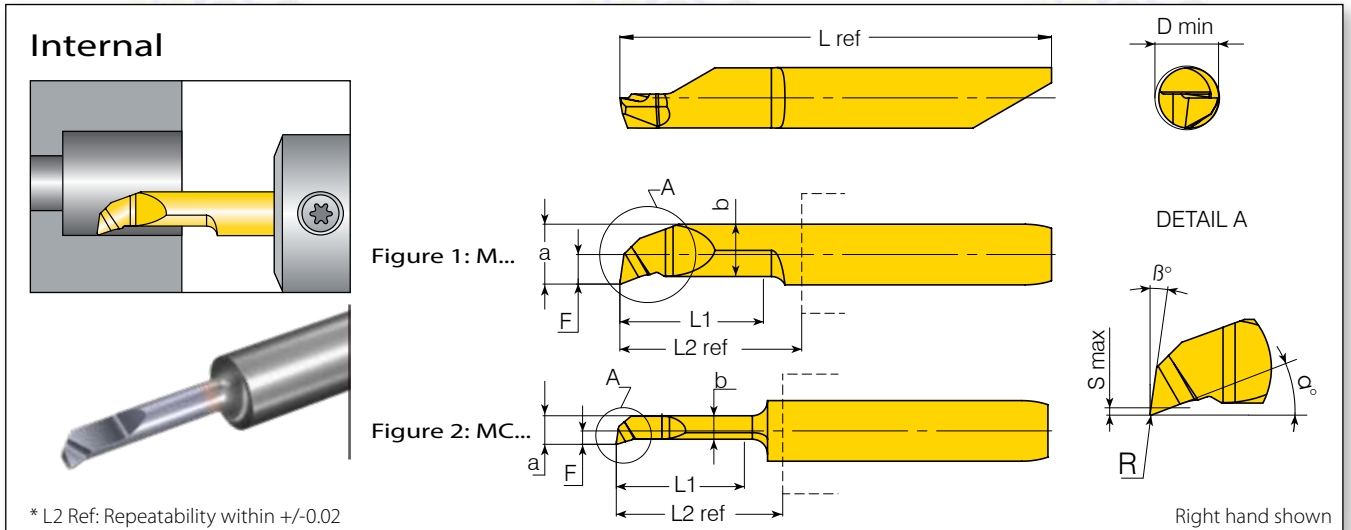

* L2 Ref: Repeatability within +/-0.02

Shank Dia.	Min. Bore Dia.	Ordering Code	Dimensions mm								Grades			
d (mm)	D min. (mm)	RH/LH	L1	R	F	S max	a	b	α°	β°	L2 ref*	L ref	VBX	VTX
4.0	1.0	MC410BCR05L04R	4.0	0.05	0.48	0.1	0.96	0.71	16.4	8	8.8	25.75	•	•
		MC410BCR05L04L	4.0	0.05	0.48	0.1	0.96	0.71	16.4		8.8	25.75	•	◦
		MC410BCR10L04R/L	4.0	0.1	0.48	0.1	0.96	0.71	17		8.8	25.75	•	◦
		MC410BCR05L06R	6.0	0.05	0.48	0.15	0.96	0.71	16.4		8.8	25.75	•	•
		MC410BCR05L06L	6.0	0.05	0.48	0.15	0.96	0.71	16.4		8.8	25.75	•	◦
		MC410BCR10L06R/L	6.0	0.1	0.48	0.15	0.96	0.81	17		8.8	25.75	•	◦
	1.5	MC415BCR05L04R	4.0	0.05	0.74	0.15	2.74	1.15	16	8	11.5	28.5	•	◦
		MC415BCR10L09R	9.0	0.1	0.74	0.15	1.45	1.22	16		11.5	28.5	•	◦
		MC415BCR10L09L	9.0	0.1	0.74	0.15	1.45	1.22	16		11.5	28.5	•	•
		MC417BCR05L06R/L	6.0	0.05	0.62	0.2	1.43	1.02	16		11.5	28.5	•	◦
		MC417BCR10L06R/L	6.0	0.1	0.77		1.58	1.18	16		11.5	28.5	•	•
		MC417BCR05L09R/L	9.0	0.05	0.62		1.43	1.04	16		11.5	28.5	•	◦
	MC417BCR10L09R/L	9.0	0.1	0.82	1.63		1.3	16	11.5	28.5	•	◦		
	1.9	MC419BCR05L06R**	6.0	0.05	0.72	0.2	1.62	1.2	16	8	11.5	28.5	•	◦
		MC419BCR05L09R/L	9.0	0.05	0.72		1.62	1.2	16		11.5	28.5	•	•
		MC422BCR05L06R/L	6.0	0.05	0.88		1.88	1.55	17.7		11.5	28.5	•	◦
		MC422BCR10L06R/L	6.0	0.1	0.93		1.93	1.55	17.7		11.5	28.5	•	◦
		MC422BCR05L09R/L	9.0	0.05	0.88		1.88	1.55	17.7		11.5	28.5	•	◦
		MC422BCR10L09R/L	9.0		0.1		0.1	2.06	1.76		17.7	11.5	28.5	•
	2.2	MC422BCR10L14R/L	14.0		1.04	2.04	1.76	17.7	18.2	35.2	•	•		
		MC422BER10L14R**	14.0	0.1	1.04	2.04	1.76	17.7	18.2	35.2	◦	•		
		MC427BCR05L10R/L	10.0		0.05	2.47	2.06	17.5	11.5	28.5	•	◦		
		MC427BCR15L10R/L	10.0		1.19	2.41	2.06	17.5	8	11.5	28.5	•	◦	
		MC427BCR15L15R/L	15.0	0.15	1.23	2.48	2.06	17.5		18.2	35.2	•	•	
MC427BER15L15R**		15.0		1.23	2.48	2.06	17.5	18.2		35.2	◦	•		
MC427BCR05L16R/L	16.0	0.05	1.22	2.47	2.06	17.5	18.2	35.2		•	•			
3.0	MC427BER05L16R**	16.0	0.05	1.22	2.47	2.06	17.5	18.2	35.2	◦	•			
	MC430BCR05L10R**	10.0	0.05	1.33	2.7	2.25	17.5	11.5	28.7	◦	•			
	MC430BCR05L16R/L	16.0	0.05	1.33	2.7	2.25	17.5	18.2	35.2	•	◦			
	MC430BCR15L20R/L	20.0	0.15	1.36	2.7	2.36	17.5	22.8	39.8	•	◦			
		MC430BCR05L26R/L	26.0	0.05	1.33	2.7	2.25	17.5	28.7	45.7	•	◦		

** LH Tools are available upon request.

• In stock ◦ Available upon request
 Inserts marked with E are available with edge prep.

ТОВ «СМАРТТЕК ІНЖИНІРИНГ», Т. +380-50-396-90-96, info@smarttec.com.ua, https://www.smarttec.com.ua



Boring (con't)

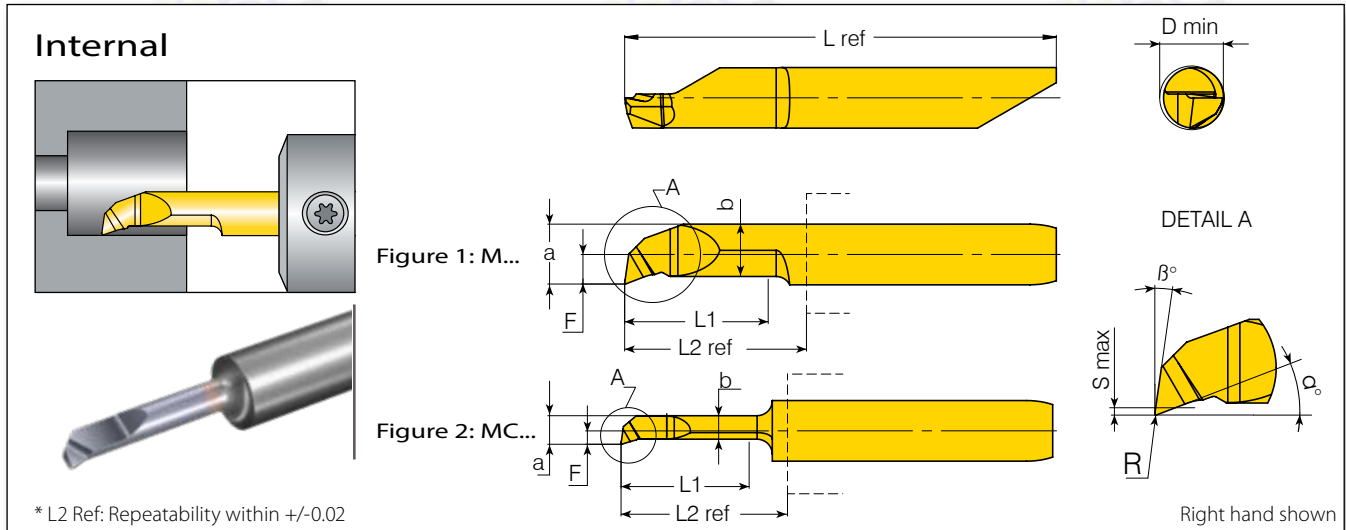

* L2 Ref: Repeatability within +/-0.02

Shank Dia. Min. Bore Dia.		Ordering Code	Dimensions mm										Grades			
d (mm)	D min. (mm)	RH/LH	L1	R	F	S max	a	b	α°	β°	L2 ref*	L ref	VBX	VTX		
4.0	3.2	MC432BCR05L10R/L	10.0	0.05	1.43		2.9	2.45	17.5			11.5	28.5	•	◦	
		MC432BCR15L10R/L	10.0	0.15	1.44		2.9	2.5	17.5			11.5	28.5	•	◦	
		MC432BCR05L16R/L	16.0	0.05	1.43		2.9	2.45	17.5			18.2	35.2	•	•	
		MC432BER05L16R**	16.0	0.05	1.43		2.9	2.45	17.5			18.2	35.2	◦	•	
		MC432BCR15L16R/L	16.0	0.15	1.44		2.87	2.5	17.5			18.2	35.2	•	•	
		MC432BER15L16R**	16.0	0.15	1.44	0.2	2.87	2.5	17.5		8	18.2	35.2	◦	•	
		MC432BCR05L20R/L	20.0	0.05	1.43		2.9	2.45	17.5				22.8	39.8	•	•
		MC432BER05L20R**	20.0	0.05	1.43		2.9	2.45	17.5				22.8	39.8	◦	•
		MC432BCR15L20R/L	20.0	0.15	1.4		2.87	2.45	17.5				22.8	39.8	•	•
		MC432BER15L20R**	20.0	0.15	1.4		2.87	2.45	17.5				22.8	39.8	◦	•
	MC432BER10L23R**	23.0	0.10	1.43		2.90	2.45	17.5				22.8	45.7	◦	•	
	MC437BCR05L10R**	3.7	10.0	0.05	1.78		3.48	3.05	17.5			11.5	28.5	•	◦	
	MC437BCR15L10R/L		10.0	0.15	1.74		3.44	3.05	17.5			11.5	28.5	•	◦	
	MC437BCR15L15R		15.0	0.15	1.74		3.44	3.05	17.5			18.2	35.2	•	•	
	MC437BCR15L15L		15.0	0.15	1.74		3.44	3.05	17.5			18.2	35.2	•	◦	
	MC437BER15L15R**		15.0	0.15	1.74	0.2	3.44	3.05	17.5		8	18.2	35.2	◦	•	
	MC437BCR15L20R		20.0	0.15	1.74		3.44	3.05	17.5			22.8	39.8	◦	•	
	MC437BCR15L20L		20.0	0.15	1.74		3.44	3.05	17.5			22.8	39.8	•	◦	
	MC437BER15L20R**		20.0	0.15	1.74		3.44	3.05	17.5			22.8	39.8	◦	•	
	MC437BCR05L26R**	26.0	0.05	1.78		3.48	3.05	17.5			28.7	45.7	◦	•		
	M442BCR03L10R**	4.2	10.0	0.03	1.98		3.98	3.13	19			11.5	28.5	◦	•	
	M442BCR05L10R**		10.0	0.05	1.95		3.95	3.45	21			11.5	28.5	•	◦	
	MS442BCR15L10R		10.0	0.15	1.93		3.93	3.13	19			11.5	28.5	•	•	
	MS442BCR15L10L		10.0	0.15	1.93		3.93	3.13	19			11.5	28.5	•	◦	
	M442BCR05L16R/L		16.0	0.05	1.95		3.95	3.45	21			18.2	35.2	•	◦	
	M442BER05L16R**		16.0	0.05	1.95		3.95	3.45	21			18.2	35.2	◦	•	
	M442BCR03L15R**		15.0	0.03	1.98		3.98	3.13	19			18.2	35.2	◦	•	
	MS442BCR15L16R		16.0	0.15	1.93		3.93	3.13	19			18.2	35.2	•	•	
	MS442BCR15L16L		16.0	0.15	1.93		3.93	3.13	19			18.2	35.2	•	◦	
	MS442BER15L16R**		16.0	0.15	1.93		3.93	3.13	19			18.2	35.2	◦	•	
	M442BCR05L21R		21.0	0.05	1.95		3.95	3.45	21			22.8	39.8	•	•	
	M442BCR05L21L		21.0	0.05	1.95		3.95	3.45	21			22.8	39.8	•	◦	
M442BER05L21R**	21.0		0.05	1.95		3.95	3.45	21			22.8	39.8	◦	•		
MS442BCR15L21R	21.0		0.15	1.93		3.93	3.13	19			22.8	39.8	•	•		
MS442BCR15L21L	21.0		0.15	1.93		3.93	3.13	19			22.8	39.8	•	◦		
MS442BER15L21R**	21.0		0.15	1.98		3.98	3.13	19			24.7	41.7	◦	•		
M442BCR03L25R**	25.0		0.03	1.98		3.98	3.13	19			28.7	45.7	◦	•		
M442BCR05L26R/L	26.0		0.05	1.95		3.95	3.45	21			28.7	45.7	•	◦		
MS442BCR15L26R/L	26.0		0.15	1.93		3.93	3.13	19			28.7	45.7	•	◦		
M442BCR05L30R**	30.0		0.05	1.95		3.95	3.45	21			33.7	50.7	•	◦		

** LH Tools are available upon request. | • In stock ◦ Available upon request | Inserts marked with E are available with edge prep.

Boring (con't)

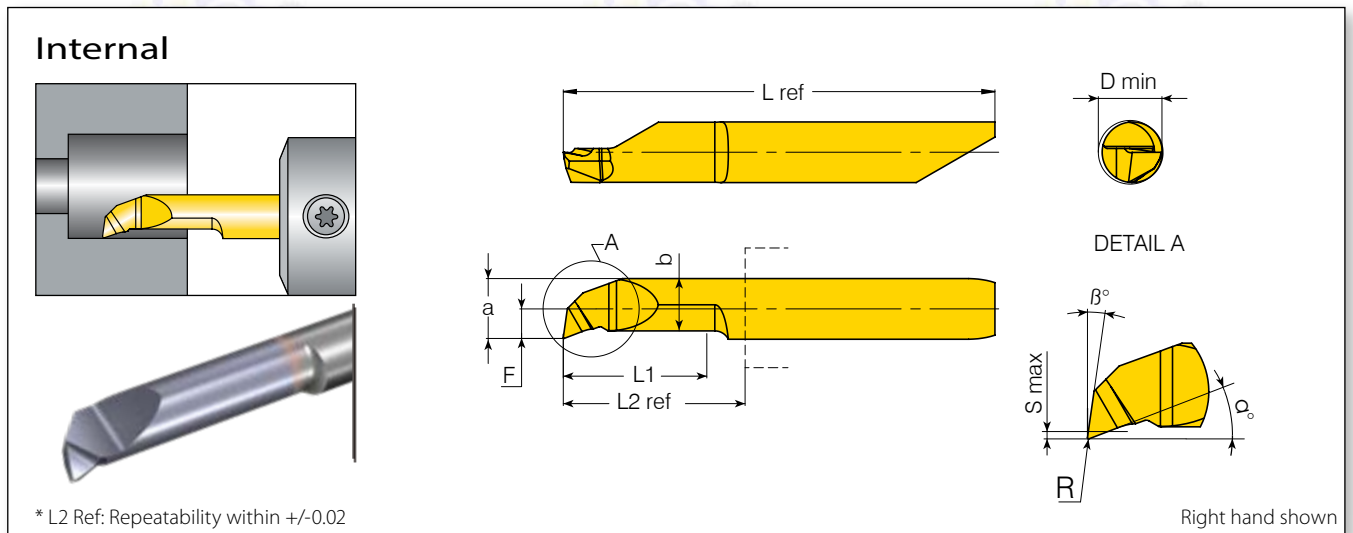

* L2 Ref: Repeatability within +/-0.02

Right hand shown

Shank Dia. Min. Bore Dia.		Ordering Code	Dimensions mm									Grades			
d (mm)	D min. (mm)	RH/LH	L1	R	F	S max	a	b	α°	β°	L2 ref*	L ref	VBX	VTX	
5.0	5.2	M552BCR05L10R**	10.0	0.05	2.43	0.5	4.93	4.24	19	21	8	12.15	35	○	●
		M552BCR20L10R/L	10.0	0.20	2.44		4.94	4.04	12.15			35	●	○	
		M552BCR03L15R**	15.0	0.03	2.44		4.94	4.24	18.15			41	○	●	
		M552BCR20L16R	16.0	0.20	2.44		4.94	4.04	18.15			41	●	●	
		M552BCR20L16L	16.0	0.20	2.44		4.94	4.04	18.15			41	●	○	
		M552BCR05L20R**	20.0	0.05	2.43		4.93	4.24	23.15			46	●	○	
		M552BCR20L20R**	20.0	0.20	2.44		4.94	4.04	23.15			46	●	○	
		M552BCR20L21R/L	21.0	0.20	2.44		4.94	4.04	23.15			46	●	●	
		M552BER20L21R**	21.0	0.20	2.44		4.94	4.04	23.15			46	○	●	
		M552BCR20L26R/L	26.0	0.20	2.44		4.94	4.04	28.15			51	●	●	
		M552BER20L26R**	26.0	0.20	2.44		4.94	4.04	28.15			51	○	●	
		M552BCR05L30R**	30.0	0.05	2.42		4.92	4.24	32.15			55	●	●	
		M552BCR20L30R/L	30.0	0.20	2.44		4.94	4.04	32.15			55	●	○	
		M552BCR20L35R	35.0	0.20	2.44		4.94	4.04	37.15			60	●	●	
M552BCR20L35L	35.0	0.20	2.44	4.94	4.04	37.15	60	●	○						
6.0	6.2	M662BCR20L16R/L	16.0	0.20	2.93	0.5	5.93	4.73	22	8	18.3	42	●	○	
		M662BCR05L20R**	20.0	0.05							23.3	47	○	●	
		M662BCR20L21R	21.0	0.20							23.3	47	●	○	
		M662BCR20L21L	21.0	0.20							23.3	47	●	●	
		M662BCR20L26R	26.0	0.20							28.3	52	●	●	
		M662BCR20L26L	26.0	0.20							28.3	52	●	○	
		M662BCR05L30R**	30.0	0.05							32.3	56	○	●	
		M662BCR20L30R/L	30.0	0.20							32.3	56	●	●	
		M662BER20L30R**	30.0	0.20							32.3	56	○	●	
		M662BCR20L35R/L	35.0	0.20							37.3	61	●	●	
		M662BER20L35R**	35.0	0.20							37.3	61	○	●	
M662BCR20L40R/L	40.0	0.20	42.3	66	●	○									
7.0	7.2	M772BCR10L15R**	15.0	0.10	3.44	0.5	6.94	5.74	22	8	16.4	41	○	●	
		M772BCR20L15R/L	15.0	16.4							41	●	○		
		M772BCR20L25R	25.0	26.4							51	●	●		
		M772BCR20L25L	25.0	26.4							51	●	○		
		M772BCR20L30R**	30.0	31.4							56	○	●		
		M772BCR20L35R/L	35.0	0.20							36.4	61	●	○	
		M772BCR20L40R/L	40.0	41.4							66	●	●		
		M772BER20L40R**	40.0	41.4							66	○	●		
		M772BCR20L45R/L	45.0	46.4							71	●	●		
		M772BER20L45R**	45.0	46.4							71	○	●		
		M772BCR20L50R/L	50.0	51.4							76	●	○		

** LH Tools are available upon request.

● In stock ○ Available upon request

Inserts marked with E are available with edge prep.



ТОВ «СМАРТТЕК ІНЖИНІРИНГ», Т. +380-50-396-90-96, info@smarttec.com.ua, https://www.smarttec.com.ua

Boring with Chip Breaker and HPC

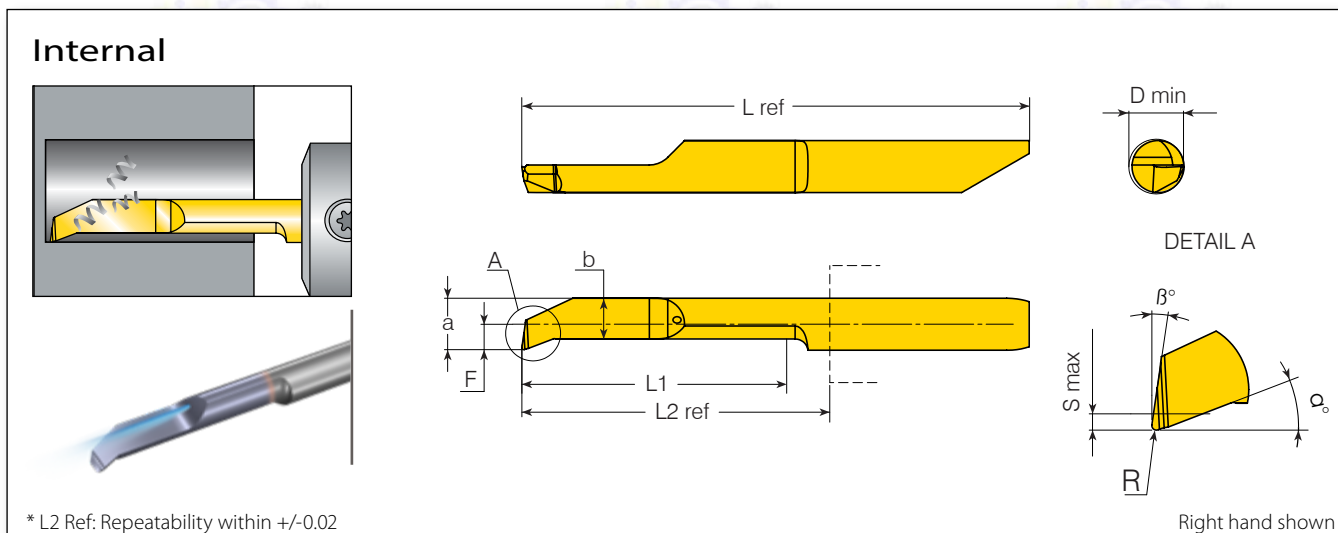

Shank Dia.	Min. Bore Dia.	Ordering Code	Dimensions mm									Grades		
d (mm)	D min. (mm)	RH/LH	L1	R	F	S max	a	b	α°	β°	L2 ref*	L ref	VBX	VTX
4.0	4.2	M442BCBR15L20RC	20	0.15	1.95	0.3	3.95	3.13			22.8	39.8	○	●
5.0	5.2	M552BCBR20L15RC	15		2.44		4.94	4.04	21	8	18.15	41	○	●
		M552BCBR20L25RC	25	0.2	2.44	0.5	4.94	4.04			28.15	51	○	●
6.0	6.2	M662BCBR20L30RC	30		2.93		5.93	4.73	22		32.3	56	○	●

■ ● In stock ○ Available upon request
■ All tools are available in LH upon request.



Boring with Chip Breaker

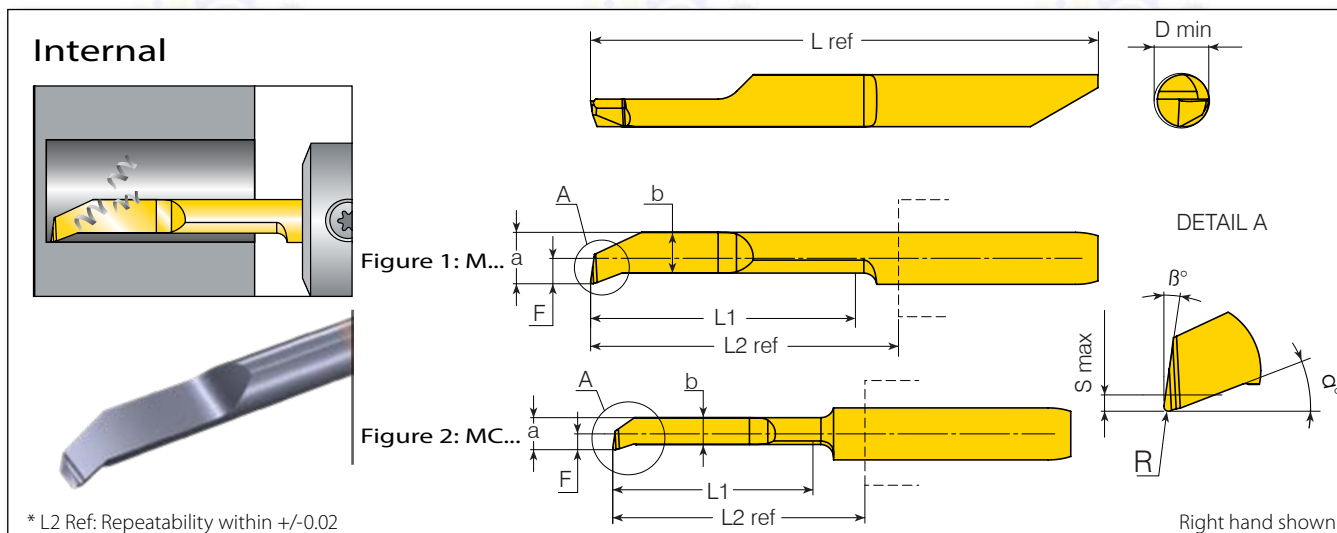

Shank Dia.	Min. Bore Dia.	Ordering Code	Dimensions mm										Grades		
d (mm)	D min. (mm)	RH/LH	L1	R	F	S max	a	b	α°	β°	L2 ref*	L ref	VBX	VTX	
4.0	2.2	MC422BCBR10L14R	14	0.1	1.04		2.04	1.76	18	8	18.2	35.2	•	◦	
	2.7	MC427BCBR15L15R		0.15	1.22		2.47	2.06			18.2	35.2	•	◦	
		MC427BCBR05L15R	15	0.05	1.22		2.47	2.06			18.2	35.2	•	◦	
	3.2	MC432BCBR05L15R		0.05	1.43		2.90	2.45			18.2	35.2	•	◦	
		MC432BCBR15L15R		0.15	1.43	0.2	2.90	2.45			18.2	35.2	•	•	
		MC432BCBR05L20R	20	0.05	1.43		2.90	2.45			22.8	39.8	•	◦	
	3.7	MC432BCBR15L20R		0.15	1.43		2.90	2.45	22.8	39.8	•	◦			
		MC437BCBR15L15R	15	0.15	1.77		3.47	3.05	18.2	35.2	•	◦			
	4.2	MC437BCBR15L20R		20	0.15	1.77		3.47	3.05	22.8	39.8	•	◦		
		M442BCBR15L12R		12	0.15	1.95		3.95	3.13	21	8	15.2	32.2	◦	•
		M442BCBR05L15R		15	0.05	1.95		3.95	3.13			18.2	35.2	•	◦
		M442BCBR15L15R		15	0.15	1.95	0.3	3.95	3.13			18.2	35.2	•	◦
M442BCBR05L20R			20	0.05	1.95		3.95	3.13	22.8			39.8	•	◦	
M442BCBR15L20R		20	0.15	1.95		3.95	3.13	22.8	39.8			•	◦		
5.0	5.2	M552BCBR20L20R	20		2.44		4.94	4.04	22	8	23.15	46	•	•	
		M552BCBR20L25R	25		2.44		4.94	4.04			28.15	51	•	◦	
6.0	6.2	M662BCBR20L30R	30	0.2	2.93	0.5	5.93	4.73	22	8	32.3	56	•	◦	
		M662BCBR20L35R	35		2.93		5.93	4.73			37.3	61	•	◦	
7.0	7.2	M772BCBR20L40R	40		3.44		6.94	5.74	22	8	41.4	66	•	◦	
		M772BCBR20L45R	45		3.44		6.94	5.74			46.4	71	•	◦	

• In stock ◦ Available upon request
 | All tools are available in LH upon request.

Boring with Chip Former and HPC

Internal

* L2 Ref: Repeatability within +/-0.02

Right hand shown

Shank Dia.	Min. Bore Dia.	Ordering Code	Dimensions mm									Grades		
d (mm)	D min. (mm)	RH/LH	L1	R	F	S max	a	b	α°	β°	L2 ref*	L ref	VBX	VTX
4.0	4.2	M442BCFR15L10RC	10.0	0.15	1.85	0.05	3.85	3.35	7.5	6	11.50	28.5	o	•

- In stock o Available upon request
- ! All tools are available in LH upon request.

Boring with Chip Former

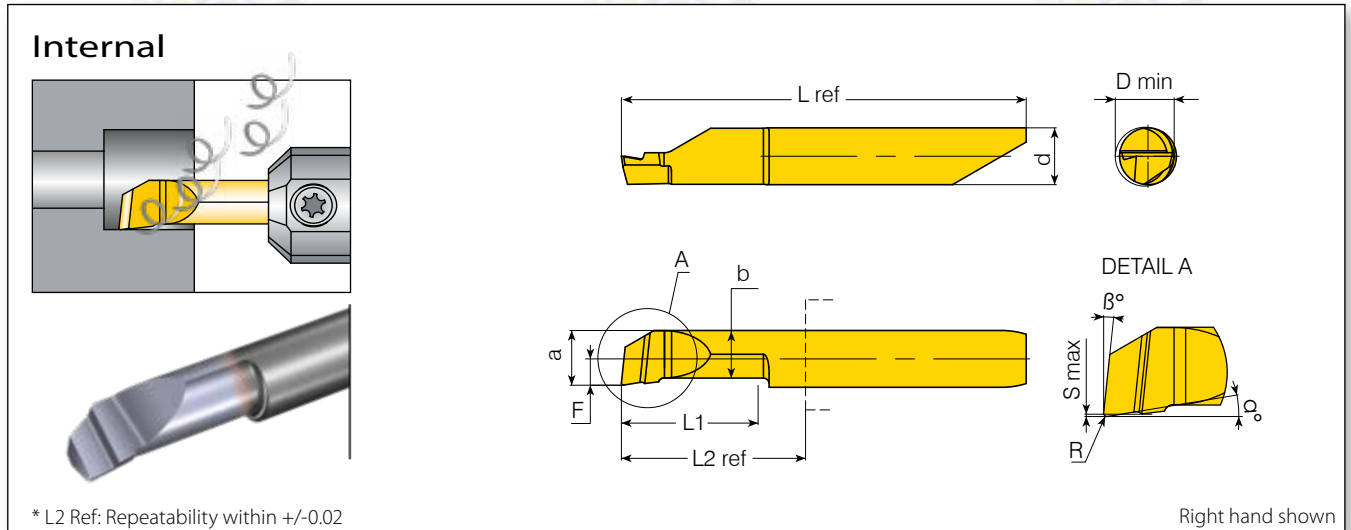

Shank Dia.	Min. Bore Dia.	Ordering Code	Dimensions mm										Grades	
d (mm)	D min. (mm)	RH/LH	L1	R	F	S max	a	b	α°	β°	L2 ref*	L ref	VBX	VTX
4.0	4.2	MS442BCFR15L10R	10.0	0.15							11.50	28.5	•	•
		MS442BCFR15L10L	10.0	0.15							11.50	28.5	•	○
		M442BCFR20L10R	10.0	0.20							11.50	28.5	○	•
		MS442BCFR15L15R	15.0	0.15	1.85		3.85	3.35			18.20	35.2	•	•
		MS442BCFR15L15L	15.0	0.15							18.20	35.2	•	○
		MS442BCFR15L20R	20.0	0.15							22.80	39.8	•	•
		MS442BCFR15L20L	20.0	0.15							22.80	39.8	•	○
5.0	5.2	M552BCFR20L10R	10.0								12.15	35.0	•	•
		M552BCFR20L15R	15.0							18.15	41.0	•	•	
		M552BCFR20L20R	20.0								23.15	46.0	•	•
		M552BCFR20L20L	20.0		2.35		4.85	4.25			23.15	46.0	•	○
		M552BCFR20L25R	25.0								28.15	51.0	•	•
		M552BCFR20L30R	30.0							9.47	6	32.15	55.0	•
6.0	6.2	M662BCFR20L15R	15.0								18.30	42.0	•	•
		M662BCFR20L20R	20.0								23.30	47.0	•	•
		M662BCFR20L20L	20.0								23.30	47.0	•	○
		M662BCFR20L25R	25.0	0.2	2.85		5.85	5.1			28.30	52.0	•	•
		M662BCFR20L30R	30.0								32.30	56.0	•	•
		M662BCFR20L30L	30.0								32.30	56.0	•	○
		M662BCFR20L35R	35.0								37.30	61.0	•	•
7.0	7.2	M772BCFR20L15R	15.0								16.40	41.0	•	•
		M772BCFR20L20R	20.0								26.40	51.0	•	○
		M772BCFR20L25R	25.0								26.40	51.0	•	○
		M772BCFR20L30R	30.0		3.4		6.9	6.1			36.40	61.0	•	○
		M772BCFR20L35R/L	35.0								36.40	61.0	•	○
		M772BCFR20L40R	40.0								41.40	66.0	•	○

• In stock ○ Available upon request
 ! All tools are available in LH upon request.

ТОВ «СМАРТТЕК ІНЖИНІРИНГ», Т. +380-50-396-90-96, info@smarttec.com.ua, https://www.smarttec.com.ua

Boring 20°

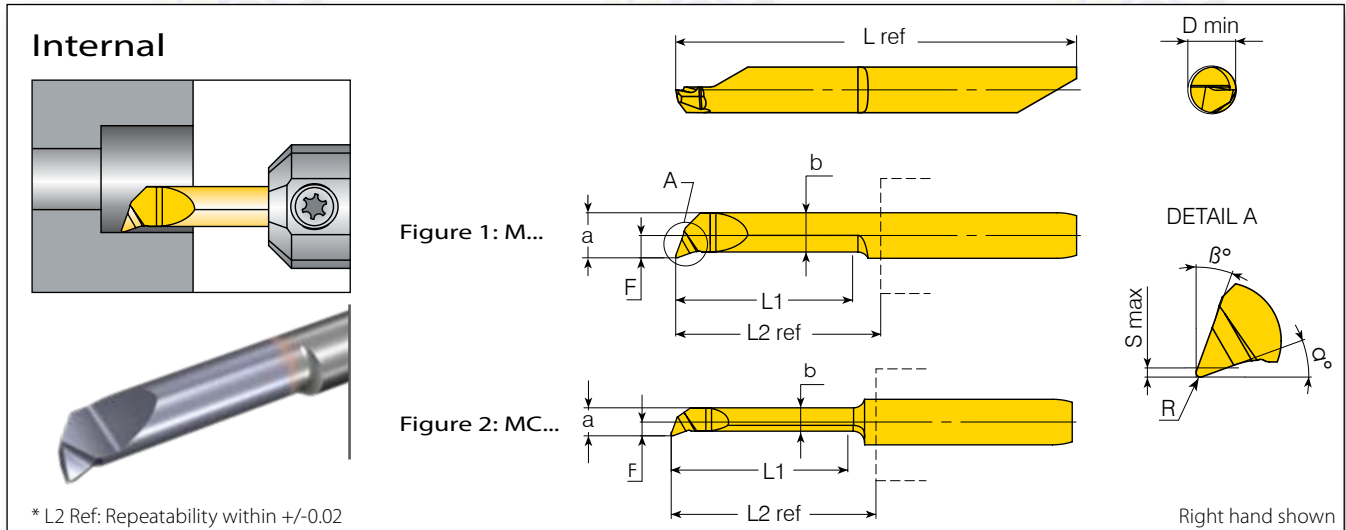

* L2 Ref: Repeatability within +/-0.02

Shank Dia.	Min. Bore Dia.	Ordering Code	Dimensions mm										Grades					
d (mm)	D min. (mm)	RH/LH	L1	R	F	S max	a	b	α°	β°	L2 ref*	L ref	VBX	VTX				
4.0	2.2	MC422B20R10L09R	9.0	0.1	0.95		1.95	1.55	20	20	11.5	28.5	•	◦				
		MC427B20R15L10R	10.0										•	•				
	2.7	MC427B20R15L16R	16.0		1.2	0.2	2.45	2.05			18.2	35.2	•	◦				
		MC427B20R15L16L	16.0									◦	•					
	3.2	MC432B20R15L10R	10.0	0.15	1.45		2.95	2.55			11.5	28.5	•	•				
		MC432B20R15L16R/L	16.0										•	•				
	4.2	M442B20R15L16R	16.0												18.2	35.2	•	•
		M442B20R15L21R/L	21.0															

• In stock ◦ Available upon request
 | All tools are available in LH upon request.

Boring 90°

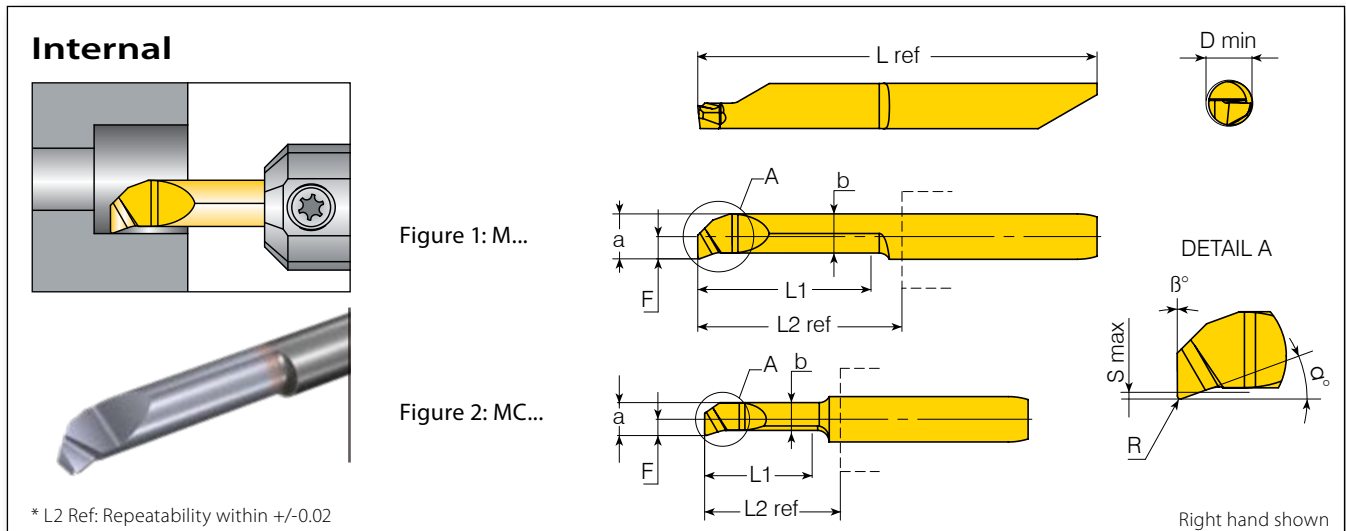

* L2 Ref: Repeatability within +/-0.02

Shank Dia.	Min. Bore Dia.	Ordering Code	Dimensions mm										Grades	
d (mm)	D min. (mm)	RH/LH	L1	R	F	S max	a	b	α°	β°	L2 ref*	L ref	VBX	VTX
4.0	3.2	MC432B90R15L10R	10.0	0.15	1.43	0.2	2.90	2.45	18	0	11.5	25.8	•	◦
		MC432B90R15L10L	10.0										•	•
	4.2	M442B90R15L16R/L	16.0		1.95	0.3	3.95	3.45			18.2	35.2	•	◦
5.0	5.2	M552B90R20L10R/L	10.0	0.2	2.44	0.5	4.94	4.2	20	0	12.15	35	•	◦
		M552B90R20L16R/L	16.0								18.15	41	•	◦
		M552B90R20L21R/L	21.0								23.15	46	•	◦

• In stock ◦ Available upon request

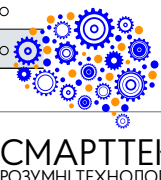

Boring & Profiling with Chip Breaker & High Pressure Coolant (CBLF)

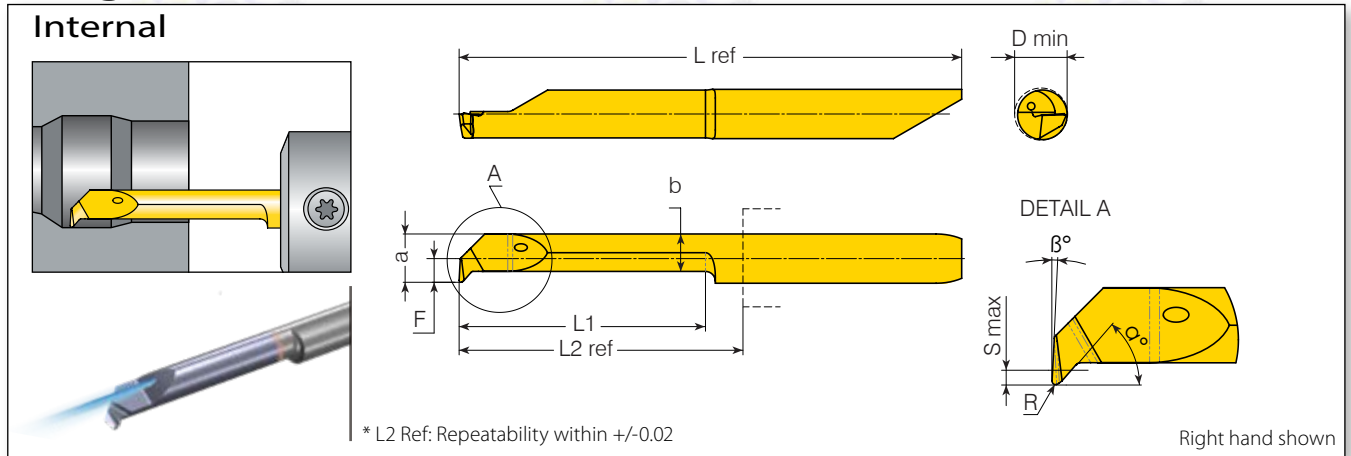

Shank Dia.	Min. Bore Dia.	Ordering Code	Dimensions mm										Grades	
d (mm)	D min. (mm)	RH/LH	L1	R	F	S max	a	b	α°	β°	L2 ref*	L ref	VBX	VTX
4.0	4.2	M442CBLFR15 L10R/LC	10								11.5	28.5	o	•
		M442CBLFR15L16R/LC	16	0.15	1.9	0.7	3.9	3.1	47		18.2	35.2	o	•
		M442CBLFR15L21R/LC	21								22.8	39.8	o	•
5.0	5.2	M552CBLFR20L16R/LC	16	0.2	2.4	0.95	4.9	3.8	49	3	18.15	41	o	•
		M552CBLFR20L25R/LC	25								28.15	51	o	•
6.0	6.2	M662CBLFR20L16R/LC	16								18.3	42	o	•
		M662CBLFR20L21R/LC	21	0.2	2.78	1.75	5.8	3.9	49		23.3	47	o	•
		M662CBLFR20L30R/LC	30								32.3	56	o	•

• In stock ◦ Available upon request
 Inserts marked with **C** are available with internal coolant.

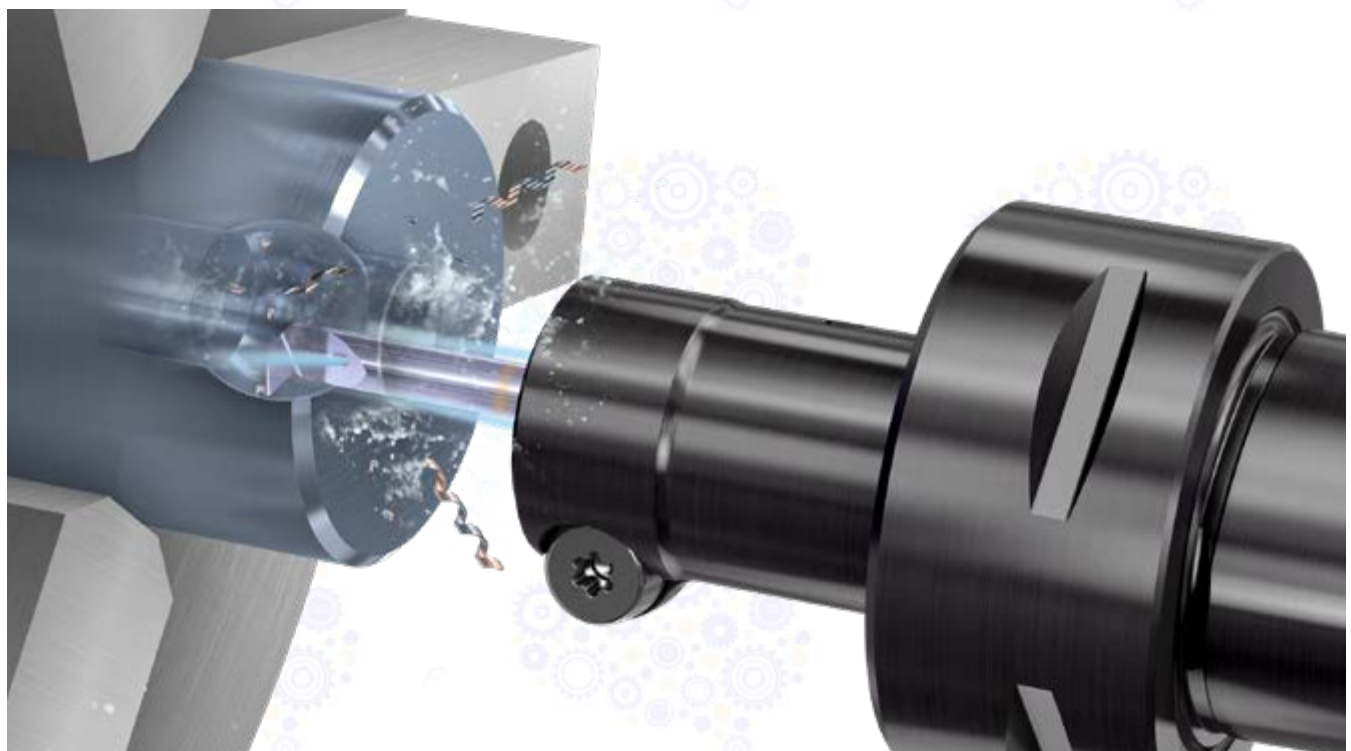

ТОВ «СМАРТТЕК ІНЖИНІРИНГ», Т. +380-50-396-90-96, info@smarttec.com.ua, https://www.smarttec.com.ua

Boring & Profiling (CL) with High Pressure Coolant

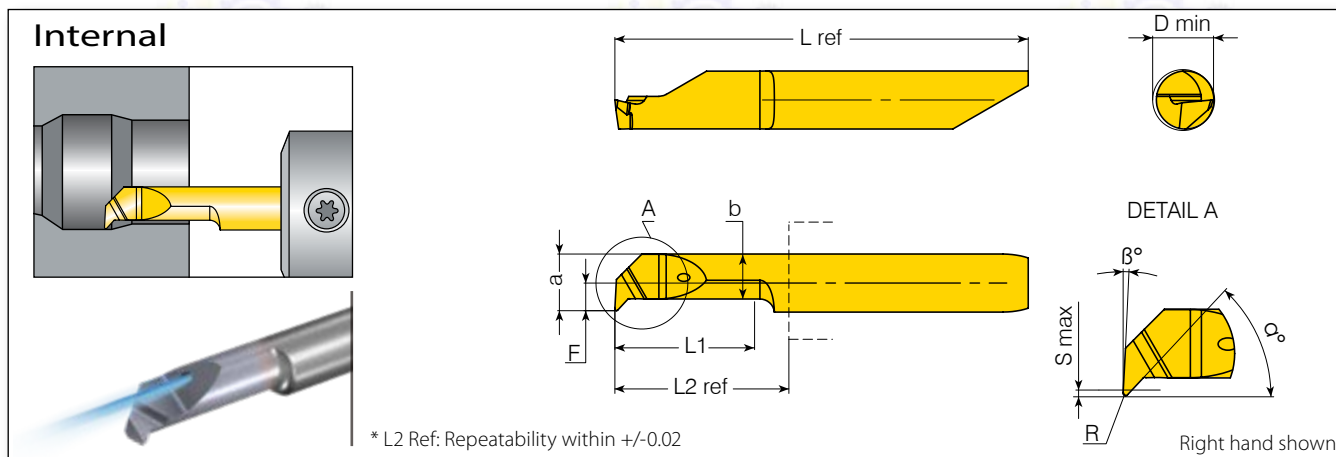

Shank Dia.	Min. Bore Dia.	Ordering Code	Dimensions mm								Grades			
d (mm)	D min. (mm)	RH/LH	L1	R	F	S max	a	b	α°	β°	L2 ref*	L ref	VBX	VTX
4.0	4.2	M442CLR15L10RC	10	0.15	1.9	0.7	3.9	3.1	47	3	11.5	28.5	○	●
		M442CLR15L21RC	21								18.2	35.2	○	●
5.0	5.2	M552CLR20L25RC	25	0.2	2.4	0.95	4.9	3.8	49		28.15	51	○	●

● In stock ○ Available upon request

Boring & Profiling (CL)

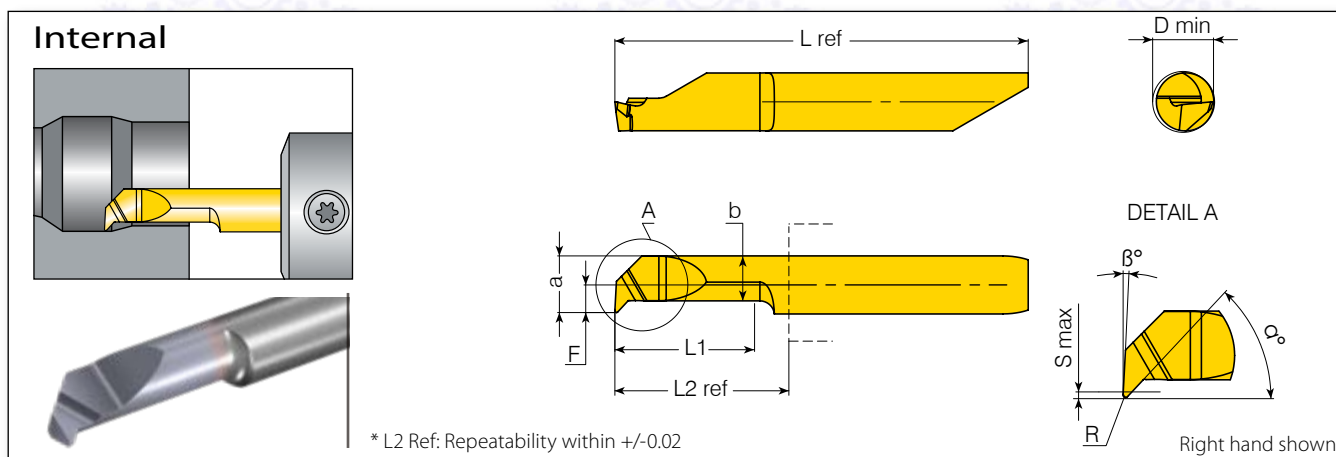

Shank Dia.	Min. Bore Dia.	Ordering Code	Dimensions mm								Grades			
d (mm)	D min. (mm)	RH/LH	L1	R	F	S max	a	b	α°	β°	L2 ref*	L ref	VBX	VTX
4.0	4.2	MS442CLR10L10R	10	0.10	1.9	0.7	3.9	3.1	47	3	11.5	28.5	●	○
		MS442CLR15L10R	10								11.5	28.5	●	●
		MS442CLR15L10L	10	11.5							28.5	●	○	
		MS442CLR15L16R/L	16	0.15							18.2	35.2	●	○
		MS442CLR15L21R	21								22.8	39.8	●	●
		MS442CLR15L21L	21	22.8							39.8	●	○	
5.0	5.2	M552CLR07L07R	7	0.07	2.4	0.95	4.9	3.75	49	3	18.2	35.2	○	●
		M552CLR20L16R	16								18.15	41	●	●
		M552CLR20L16L	16	18.15							41	●	○	
		M552CLR20L25R	25	0.2							28.15	51	●	●
		M552CLR20L25RL	25								28.15	51	●	○
6.0	6.2	M662CLR10L16R	16	0.1	2.78	1.75	5.78	3.9	49	3	18.3	42	○	●
		M662CLR20L16R	16								18.3	42	●	●
		M662CLR20L16L	16	18.3							42	●	○	
		M662CLR20L21R/L	21	0.2							23.3	47	●	○
		M662CLR20L30R/L	30								32.3	56	●	○

● In stock ○ Available upon request

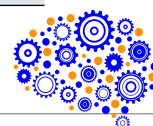

Back Boring

Internal

* L2 Ref: Repeatability within +/-0.03

Right hand shown

Shank Dia.	Min. Bore Dia.	Ordering Code	Dimensions mm										Grades		
d (mm)	D min. (mm)	RH/LH	L1	R	F	S max	a	b	α°	β°	L2 ref*	L3	L ref	VBX	VTX
4.0	4.2	M442BBR15L25R/L	25.0	0.15	1.95	0.8	3.95	2.6	30	6	26.4	2.30	45.7	•	◦
5.0	5.2	M552BBR15L30R/L			2.45	1.0	4.95	3.8		7	29.85		55.0	•	◦
6.0	6.2	M662BBR15L30R/L	30.0		2.95	1.8	5.95	4.0	7	29.8	56.0	•	◦		
7.0	7.2	M772BBR15L30R/L			3.45	2.5	6.95	4.3	7	34	61.0	•	◦		

• In stock ◦ Available upon request

Boring & Chamfering 45°

Internal

* L2 Ref: Repeatability within +/-0.02

Right hand shown

Shank Dia.	Min. Bore Dia.	Ordering Code	Dimensions mm										Grades	
d (mm)	D min. (mm)	RH/LH	L1	R	F	S max	a	b	α°	L2 ref*	L ref	VBX	VTX	
4.0	4.2	MS442CH4545L15R/L	15.0	0.2	1.95	0.7	3.95	2.8	45	18.4	35.4	•	◦	
5.0	5.2	M552CH4545L15R/L	15.0		2.45		4.95	3.7		18.35	41.2	•	◦	
		M552CH4545L20R/L	20.0		23.35		46.2	•		◦				
6.0	6.2	M662CH4545L20R/L	20.0		2.95		5.95	4.0		23.5	47.2	•	◦	
		M662CH4545L25R/L	25.0	28.5	52.2	•	◦							
7.0	7.2	M772CH4545L20R/L	20.0	3.45	6.95	4.25	26.6	51.2	•	◦				
		M772CH4545L40R/L	40.0				41.6	66.2	•	◦				

• In stock ◦ Available upon request

ТОВ «СМАРТТЕК ІНЖИНІРИНГ», Т. +380-50-396-90-96, info@smarttec.com.ua, https://www.smarttec.com.ua

Square Grooving with High Pressure Coolant

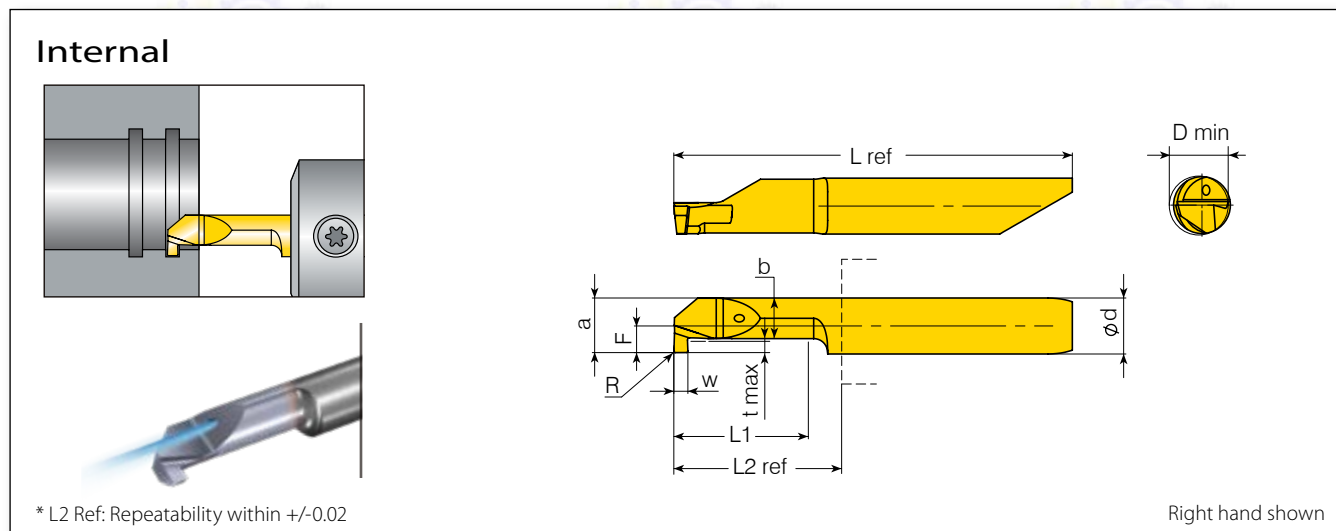

Shank Dia.	Min. Bore Dia.	Ordering Code	Dimensions mm										Grades	
d (mm)	D min. (mm)	RH/LH	W ^{±0.025}	t max	L1	F	R	a	b	L2 ref*	L ref	VBX	VTX	
4.0	4.2	M442GSW100L10RC**	1.00	0.8	10	1.90	0.1	3.90	2.9	11.5	28.5	○	●	
		M442GSW100L15RC**	1.00	0.8	15	1.90	0.1	3.90	2.9	18.2	35.2	○	●	
		M442GSW100L20RC**	1.00	0.8	20	1.90	0.1	3.90	2.9	22.8	39.8	○	●	
5.0	5.2	M552GSW100L10RC**	1.00	1	10	2.40	0.1	4.90	3.7	12.15	35	○	●	
		M552GSW100L15RC**	1.00	1	15	2.40	0.1	4.90	3.7	18.15	41	○	●	
		M552GSW150L15RC**	1.50	1	15	2.40	0.1	4.90	3.7	18.15	41	○	●	
		M552GSW150L20RC**	1.50	1	20	2.40	0.1	4.90	3.7	23.15	46	○	●	

** LH Tools are available upon request.

● In stock ○ Available upon request

Inserts marked with C are available with internal coolant.



Square Grooving

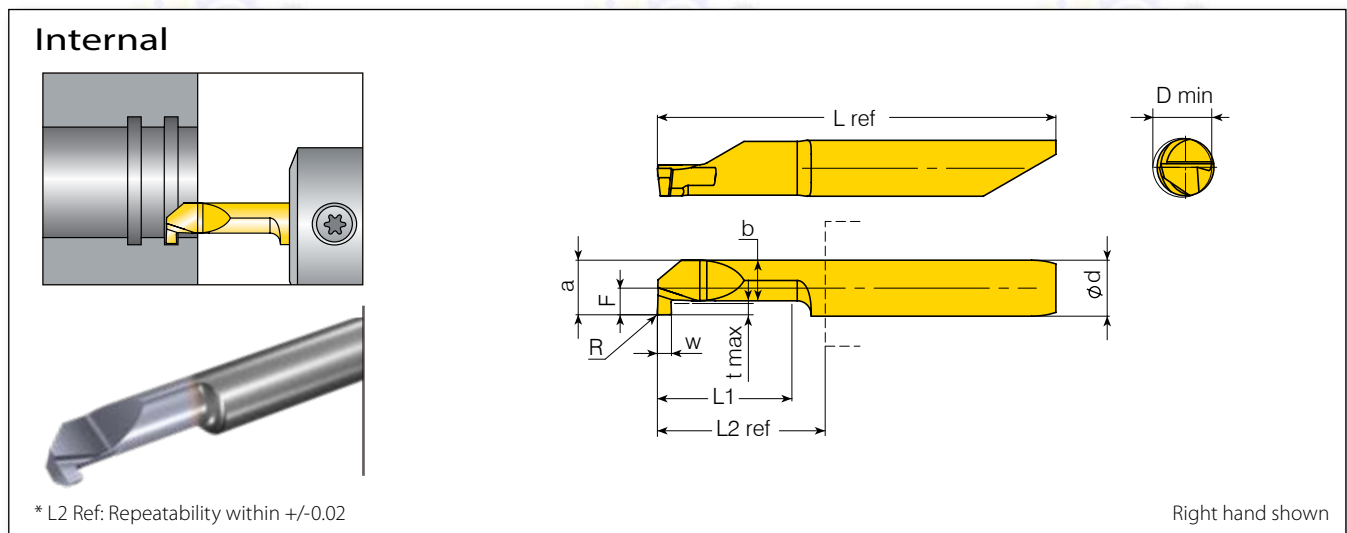

Shank Dia.	Min. Bore Dia.	Ordering Code	Dimensions mm										Grades									
d (mm)	D min. (mm)	RH/LH	W ^{+0.025}	t max	L1	F	R	a	b	L2 ref*	L ref	VBX	VTX									
4.0	3.0	MS430GSW070L16R	0.70	0.62	16	1.40	0.1	2.70	1.75	11.5	39.8	○	●									
	4.0	MS440GSW100L10R	1.00	1	10	1.90	0	3.90	2.5	18.2	35.2	○	●									
	4.2	MS442GSW079L10R/L	0.79	0.8	10	1.96	0.1	3.96	2.9	11.5	28.5	28.5	●	○								
		MS442GSW100L10R/L	1.00			1.90	0.1	3.90	2.9	11.5	28.5	28.5	●	○								
		MS442GSW150L10R**	1.50			1.90	0.1	3.90	2.9	18.2	35.2	●	○									
		MS442GSW079L15R/L	0.79											15	1.96	0.1	3.96	2.9	18.2	35.2	●	○
		MS442GSW100L15R/L	1.00											1.90	0.1	3.90	2.9	18.2	35.2	●	○	
		MS442GSW100L20R/L	1.00											20	1.90	0.1	3.90	2.9	22.8	39.8	●	○
MS442GSW079L25R/L	0.79	25	1.96	0.1	3.96	2.9	28.7	45.7	●	○												
5.0	5.2	M552GSW070L06L	0.70	1	6	2.40	0.1	4.90	3.7	12.15	32	○	●									
		M552GSW100L10R/L	1.00	1	10	2.40	0.1	4.90	3.7	12.15	35	●	○									
		M552GSW179L10R	1.79	1.35	10	2.40	0.1	4.90	3.7	12.15	35	○	●									
		M552GSW150L10R**	1.50	1	10	2.40	0.1	4.90	3.7	12.15	35	●	○									
		M552GSW200L10R**	2.00	1	10	2.40	0.1	4.90	3.7	12.15	35	●	○									
		M552GSW100L15R/L	1.00	1	15	2.40	0.1	4.90	3.7	18.15	41	●	○									
		M552GSW150L15R/L	1.50	1	15	2.40	0.1	4.90	3.7	18.15	41	●	○									
		M552GSW200L15R**	2.00	1	15	2.40	0.1	4.90	3.7	18.15	41	●	○									
		M552GSW100L20R/L	1.00	1	20	2.40	0.1	4.90	3.7	23.15	46	●	○									
		M552GSW150L20R/L	1.50	1	20	2.40	0.1	4.90	3.7	23.15	46	●	○									
		M552GSW200L20R**	2.00	1	20	2.40	0.1	4.90	3.7	23.15	46	●	○									
		M552GSW050L21R	0.50	1	21	2.40	0.1	4.90	3.7	23.15	46	○	●									
6.0	5.2	M652GSW160L10R	1.60	1.8	10	2.20	0.1	5.20	2.9	12.3	36	○	●									
	6.2	M662GSW150L06R	1.50	1.8	6	0.40	0.1	3.40	1.7	12.3	40	○	●									
		M662GSW080L09R	0.80	1.8	9	2.96	0.1	5.96	4	11.3	35	○	●									
		M662GSW079L10R**	0.79			2.90		5.90		12.3	36	●	○									
		M662GSW100L10R/L	1.00			2.90		5.90		12.3	36	●	○									
		M662GSW117L10R**	1.17			2.90		5.90		12.3	36	●	○									
		M662GSW150L10R	1.50			2.90		5.90	4.0	12.3	36	●	○									
		M662GSW150L10L	1.50		10	2.90		5.90		12.3	36	○	●									
		M662GSW157L10R**	1.57	1.8		2.90	0.1	5.94		12.3	36	●	○									
		M662GSW198L10R**	1.98			2.90		5.94		12.3	36	●	○									
		M662GSW200L10R/L	2.00			2.90		5.90		12.3	36	●	○									
		M662GSW079L15R**	0.79			2.90		5.94	4.0	18.3	42	●	○									
		M662GSW100L15R	1.00		15	2.90		5.90		18.3	42	●	●									
		M662GSW100L15L	1.00			2.90		5.90		18.3	42	●	○									

** LH Tools are available upon request.
 ● In stock ○ Available upon request

ТОВ «СМАРТТЕК ІНЖИНІРИНГ», Т. +380-50-396-90-96, info@smarttec.com.ua, https://www.smarttec.com.ua

Square Grooving (con't)

Shank Dia.	Min. Bore Dia.	Ordering Code	Dimensions mm										Grades				
d (mm)	D min. (mm)	RH/LH	W \pm 0.025	t max	L1	F	R	a	b	L2 ref*	L ref	VBX	VTX				
6.0	6.2	M662GSW117L15R**	1.17	1.8	15	2.96	0.1	5.96	4.0	18.3	42	●	○				
		M662GSW150L15R/L	1.50			2.90		5.90				●	○				
		M662GSW157L15R**	1.57			2.96		5.96				●	○				
		M662GSW198L15R**	1.98			2.96		5.96				●	○				
		M662GSW200L15R	2.00			2.96		5.96				●	●				
		M662GSW200L15L	2.00		2.90	5.90		●				○					
		M662GSW100L20R	1.00		20	2.90		5.90				23.3	47	●	●		
		M662GSW100L20L	1.00											●	○		
		M662GSW150L20R/L	1.50											●	○		
		M662GSW200L20R	2.00											●	●		
		M662GSW200L20L	2.00	●			○										
		M662GSW079L25R**	0.79	25	2.96	5.96	4.0	28.3	52	●	○						
		M662GSW100L25R	1.00							2.90	5.90	3.1	56	○	●		
		M662GSW117L25R**	1.17							2.96	5.96	4.0	52	●	○		
		M662GSW157L25R**	1.57							2.96	5.96	4.0	52	●	○		
		M662GSW198L25R**	1.98							2.96	5.96	4.0	52	●	○		
		M662GSW200L25R	2.00							2.90	5.90	3.2	56	○	●		
		M665GSW350L25R	3.50							2.96	5.96	4.0	52	○	●		
		M662GSW100L30R/L	1.00							30	2.90	5.90	4.0	32.3	56	●	○
		M662GSW150L30R/L	1.50													4.0	●
M662GSW200L30R/L	2.00	4.0	●													○	
M662GSW079L35R**	0.79	2.96	5.96	4.0	61	●	○										
M662GSW117L35R**	1.17	2.96	5.96	4.0	61	●	○										
M662GSW150L35R	1.50	35	2.95	5.90	3.95	37.3	59.85	○	●								
M662GSW157L35R**	1.57							2.96	5.96	4.0	61	●	○				
M772GSW250L15R	2.50							15	3.40	6.90	4.1	18.3	42	○	●		
M772GSW079L10R**	0.79	10	3.40	6.90	4.1	11.4	36	●	○								
M772GSW100L10R/L	1.00							●	○								
M772GSW150L10R/L	1.50							●	○								
M772GSW200L10R/L	2.00							●	○								
M772GSW600L10R	6.00	10	3.20	6.90	4.1	11.4	36	○	●								
M772GSW079L15R**	0.79	15	3.46	6.96	4.1	16.4	41	●	○								
M772GSW100L15R**	1.00							3.40	6.90	●	○						
M772GSW117L15R**	1.17							3.46	6.96	●	○						
M772GSW150L15R/L	1.50							3.40	6.90	●	○						
M772GSW157L15R**	1.57							3.46	6.96	●	○						
M772GSW198L15R**	1.98							3.46	6.96	●	○						
M772GSW200L15R/L	2.00							3.40	6.90	●	○						
M772GSW150L16R	1.50							16	3.4	6.90	4.1	17.4	42	○	●		
M772GSW079L20R**	0.79							20	3.46	6.96	4.1	26.4	51	●	○		
M772GSW117L20R**	1.17													3.46	6.96	51	●
M772GSW157L20R**	1.57	3.46	6.96	51	●	○											
M772GSW198L20R**	1.98	3.46	6.96	51	●	○											
M772GSW150L20R	1.50	3.40	6.90	46	○	●											
M772GSW100L25R**	1.00	25	3.40	6.90	4.1	26.4	51							●	○		
M772GSW150L25R/L	1.50							51	●	○							
M772GSW200L25R/L	2.00							51	●	○							
M772GSW100L35R**	1.00							35	3.40	6.90	4.1	36.4	61	●	○		
M772GSW150L35R/L	1.50													●	○		
M772GSW200L35R/L	2.00	●	○														

** LH Tools are available upon request.

● In stock ○ Available upon request

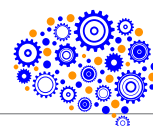

Round Grooving

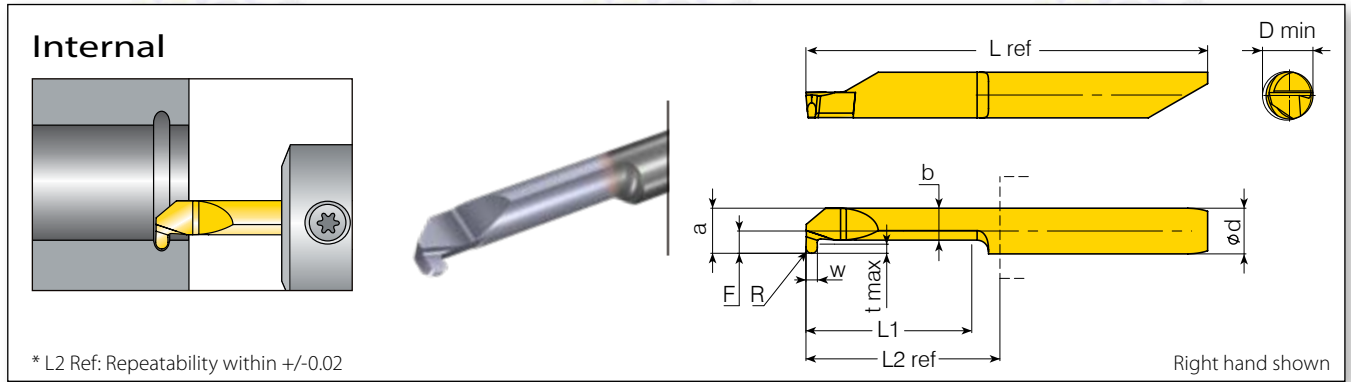

* L2 Ref: Repeatability within +/-0.02

Shank Dia.	Min. Bore Dia.	Ordering Code	Dimensions mm										Grades	
d (mm)	D min. (mm)	RH/LH	W ^{+0.025}	t max	L1	F	R	a	b	L2 ref*	L ref	VBX	VTX	
4.0	4.2	MS442GRR050L15R/L	1.0	0.8	15	1.95		3.95	2.8	18.2	35.2	•	○	
5.0	5.2	M552GRR050L20R**	1.0	1	20	2.45	0.5	4.95	3.7	23.15	46	•	•	
		M552GRR050L20L	1.0									○		
		M552GRR075L20R/L	1.5				0.75					•	○	
		M552GRR100L20R/L	2.0				1					•	○	
6.0	6.2	M662GRR100L05R**	2.0	1.6	5	2.95	1	5.95	4	18.3	42	○	•	
		M662GRR050L15R**	1.0		15		0.5					○	•	
		M662GRR050L25R/L	1.0		0.5	•	○							
		M662GRR075L25R/L	1.5	1.8	25	0.75	5.95	4	28.3	52	•	○		
		M662GRR100L25R/L	2.0		1	•	○							
7.0	7.2	M772GRR050L30R**	1.0	2.5	30	3.45	0.5	6.95	4.15	36.4	51	○	•	
		M772GRR100L30R**	2.0	2.5	30	3.45	1	6.95	4.1	36.4	61	•	○	

** LH Tools are available upon request.

• In stock ○ Available upon request

Pre-Part Off

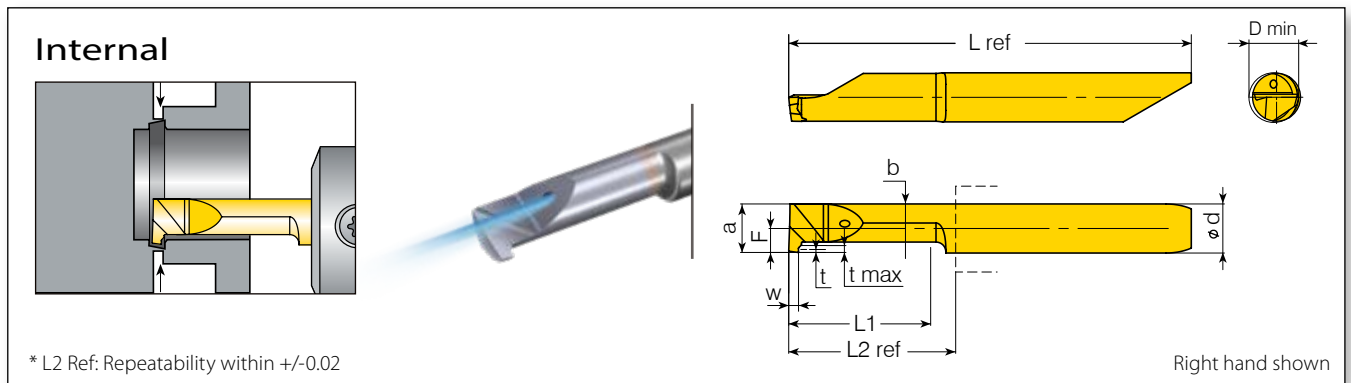

* L2 Ref: Repeatability within +/-0.02

Shank Dia.	Min. Bore Dia.	Ordering Code	Dimensions mm										Grades	
d (mm)	D min. (mm)	RH/LH	W ^{+0.025}	t max	L1	F	t	a	b	L2 ref*	L ref	VBX	VTX	
5.0	5.2	M552PPW100L15R/L	1.0	0.7	15	2.44	0.3	4.94	3.88	18.15	41	•	○	
		M552PPW100L20R/L			20							•	○	
		M552PPW100L20R**			20							○	•	
		M552PPW100L25R/L			25							•	○	
		M552PPW100L30R**			30							•	○	

** LH Tools are available upon request.

• In stock ○ Available upon request

ТОВ «СМАРТТЕК ІНЖИНІРИНГ», Т. +380-50-396-90-96, info@smarttec.com.ua, https://www.smarttec.com.ua

Face Grooving with High Pressure Coolant

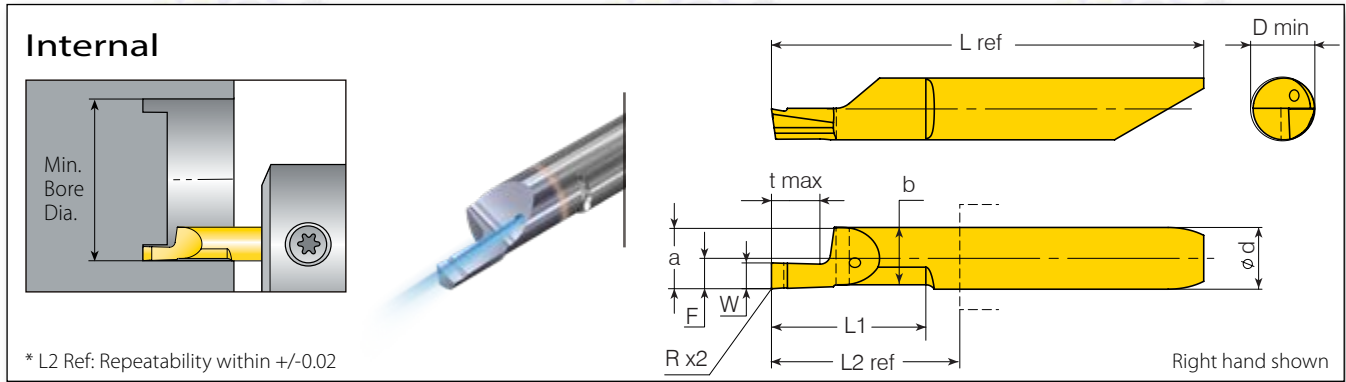

Shank Dia.	Min. Bore Dia.	Ordering Code	Dimensions mm										Grades	
d (mm)	D min. (mm)	RH/LH	W±0.025	t max	L1	F	R	a	b	L2 ref*	L ref	VBX	VTX	
6.0	8.0	M680FGW10L15R/LC	1.00	2.0	15	2.8	0.10	5.8	5.55	18.3	42.0	○	●	
		M680FGW117L15R/LC	1.17				0.15					○	●	
		M680FGW15L15R/LC	1.50	3.0			0.10					○	●	
		M680FGW157L15R/LC	1.57				0.15					○	●	
		M680FGW198L15R/LC	1.98	4.0			0.15					○	●	
		M680FGW20L15R/LC	2.00				0.10					○	●	
		M680FGW239L15R/LC	2.39	5.0			0.15					○	●	
		M680FGW25L15R/LC	2.50				0.10					○	●	
		M680FGW30L15R/LC	3.00	6.0			0.10					○	●	
		M680FGW318L15R/LC	3.18				0.15					○	●	

● In stock ○ Available upon request

Face Grooving with High Pressure Coolant

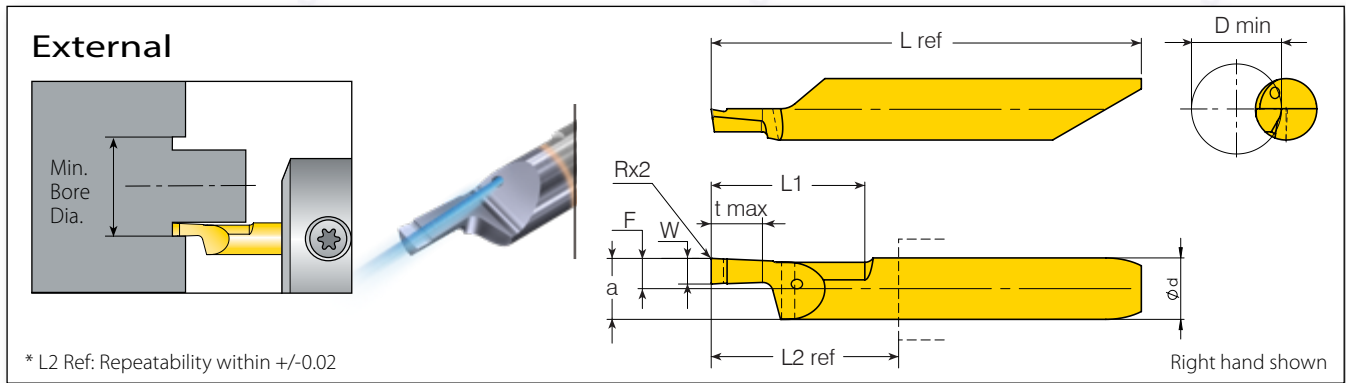

Shank Dia.	Min. Bore Dia.	Ordering Code	Dimensions mm										Grades	
d (mm)	D min. (mm)	RH/LH	W±0.025	t max	L1	F	R	a	b	L2 ref*	L ref	VBX	VTX	
6.0	8.0	M680FPW10L15R/LC	1.00	2.0	15	2.8	0.10	5.8	5.55	18.3	42.0	○	●	
		M680FPW117L15R/LC	1.17				0.15					○	●	
		M680FPW15L15R/LC	1.50	3.0			0.10					○	●	
		M680FPW157L15R/LC	1.57				0.15					○	●	
		M680FPW198L15R/LC	1.98	4.0			0.15					○	●	
		M680FPW20L15R/LC	2.00				0.10					○	●	
		M680FPW239L15R/LC	2.39	5.0			0.15					○	●	
		M680FPW25L15R/LC	2.50				0.10					○	●	
		M680FPW30L15R/LC	3.00	6.0			0.10					○	●	
		M680FPW318L15R/LC	3.18				0.15					○	●	

● In stock ○ Available upon request

ТОВ «СМАРТТЕК ІНЖИНІРИНГ», Т. +380-50-396-90-96, info@smarttec.com.ua, https://www.smarttec.com.ua



Face Grooving

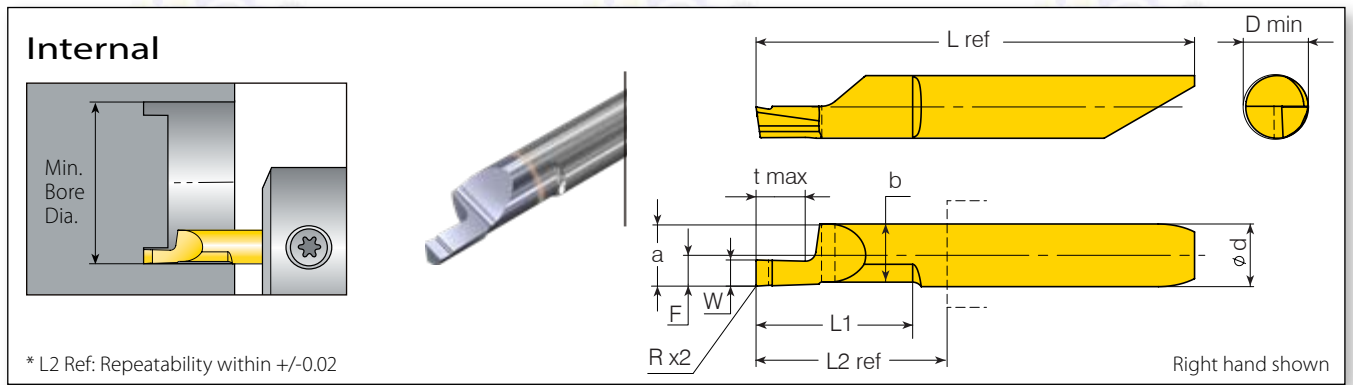

Shank Dia.	Min. Bore Dia.	Ordering Code	Dimensions mm										Grades	
d (mm)	D min. (mm)	RH/LH	W±0.025	t max	L1	F	R	a	b	L2 ref*	L ref	VBX	VTX	
6.0	6.2	MN662FGW10L15R/L	1.00	2.0	15	2.95	0.10	5.95	5.57	18.3	42.0	○	●	
		MN662FGW117L15R/L	1.17				0.15					○	●	
		MN662FGW15L15R/L	1.50	3.0			0.10					○	●	
		MN662FGW157L15R/L	1.57				0.15					○	●	
		MN662FGW198L15R/L	1.98	4.0			0.15					○	●	
		MN662FGW20L15R/L	2.00				0.10					○	●	
		MN662FGW239L15R/L	2.39	5.0			0.15					○	●	
		MN662FGW25L15R/L	2.50				0.10					○	●	
	MN662FGW30L15R/L	3.00	6.0	0.10			○					●		
	MN666FGW318L15R/L	3.18		0.15			○					●		
	6.6													

● In stock ○ Available upon request

Face Grooving

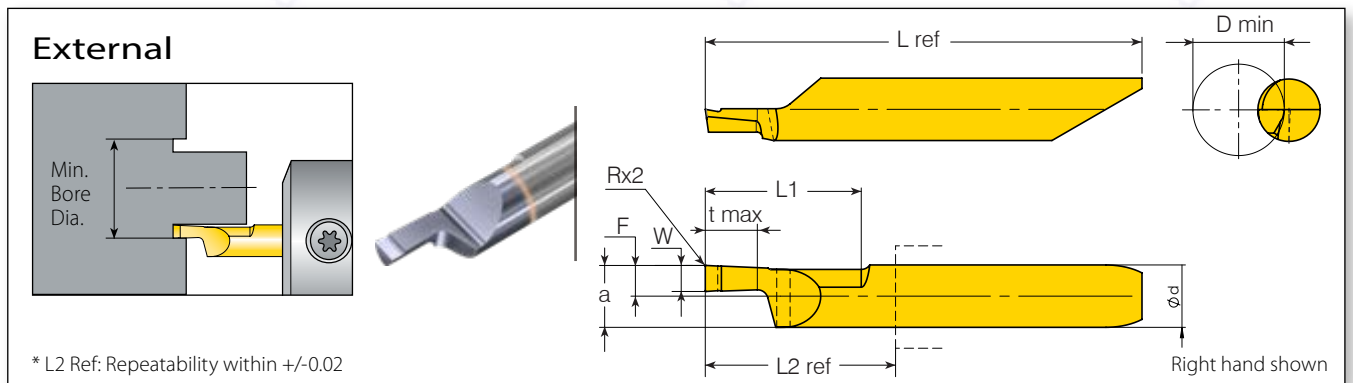

Shank Dia.	Min. Bore Dia.	Ordering Code	Dimensions mm										Grades	
d (mm)	D min. (mm)	RH/LH	W±0.025	t max	L1	F	R	a	b	L2 ref*	L ref	VBX	VTX	
6.0	6.2	MN662FPW10L15R/L	1.00	2.0	15	2.95	0.10	5.95	5.57	18.3	42.0	○	●	
		MN662FPW117L15R/L	1.17				0.15					○	●	
		MN662FPW15L15R/L	1.50	3.0			0.10					○	●	
		MN662FPW157L15R/L	1.57				0.15					○	●	
		MN662FPW198L15R/L	1.98	4.0			0.15					○	●	
		MN662FPW20L15R/L	2.00				0.10					○	●	
		MN662FPW239L15R/L	2.39	5.0			0.15					○	●	
		MN662FPW25L15R/L	2.50				0.10					○	●	
	MN662FPW30L15R/L	3.00	6.0	0.10			○					●		
	MN666FPW318L15R/L	3.18		0.15			○					●		
	6.6													

● In stock ○ Available upon request

Round Face Grooving with High Pressure Coolant

NEW

Internal

* L2 Ref: Repeatability within +/-0.02

Right hand shown

Shank Dia.	Min. Bore Dia.	Ordering Code	Dimensions mm									Grades	
d (mm)	D min.	RH/LH	W±0.025	t max	L1	F	R	a	b	L2 ref*	L ref	VBX	VTX
6.0	6.2	M662FGR050L15R/LC	1	2	15	2.8	0.5	5.8	5.55	18.3	42	○	●
		M662FGR080L15R/LC	1.6	3			0.8					○	●
		M662FGR100L15R/LC	2	4	1	○	●						
		M662FGR125L15R/LC	2.5	5	1.25	○	●						
		M662FGR150L15R/LC	3	6	1.5	○	●						

● In stock ○ Available upon request

Face Chamfering 45°

Internal

* L2 Ref: Repeatability within +/-0.02

Right hand shown

Shank Dia.	Min. Bore Dia.	Ordering Code	Dimensions mm						Grades	
d (mm)	D min. (mm)	RH/LH	R	F	S max	β°	L2 ref*	L ref	VBX	VTX
4.0	1.0	M410CH45L15R	0.1	0.75	2.4	45	18.2	35.2	●	○
		M410CH45L15L							○	●

● In stock ○ Available upon request

ТОВ «СМАРТТЕК ІНЖИНІРИНГ», т. +380-50-396-90-96, info@smarttec.com.ua, https://www.smarttec.com.ua



СМАРТТЕК
РОЗУМНІ ТЕХНОЛОГІЇ

Threading

Internal

* L2 Ref: Repeatability within +/-0.02

Right hand shown

Partial Profile 60°

Thread	Shank Dia. d (mm)	Min. Bore Dia. D min. (mm)	Ordering Code	Pitch		Dimensions mm							Grades		
				RH/LH	mm	TPI	L1	a	F	Y	h (min)	L2 ref*	L ref	Helix°	VBX
M1-M2x0.25	4.0	0.73	M407TH0.25P60L02R	0.25		2.5	0.65	1.95	0.14	0.29	13.0	29.8	4.9	○	●
M1.6-M3x0.35		1.22	M412TH0.35P60L04R	0.35		4	1.10		0.18	0.29				○	●
M2x0.4		1.57	M416TH0.40P60L05R	0.4		5	1.45		0.2	0.41				○	●
M2.2-M2.5x0.45		1.71	M417TH0.45P60L06R	0.45		6	1.54	0.22	0.46	○				●	
-	4.0	3.2	MS429THF60L16R	0.5-1.0	48-24	16	2.90	0.9	0.9	-	18.4	35.4	3.5	●	○
		3.2	MS429THF60L16L	0.5-1.0	48-24	16	2.90	0.9						○	●
		4.2	MS439THF60L16R	0.5-1.0	48-24	16	3.89	1.9						●	○
		4.2	MS439THF60L16L	0.5-1.0	48-24	16	3.89	1.9						○	●
	6.0	6.2	M659THA60L06R	0.5-1.5	48-16	6	5.89	2.9			○	●			
		6.2	M659THA60L16R	0.5-1.5	48-16	16	5.89	2.9			●	●			
		6.2	M659THA60L16L	0.5-1.5	48-16	16	5.89	2.9	○	○					

● In stock ○ Available upon request

Partial Profile 55°

d (mm)	Shank Dia. d (mm)	Min. Bore Dia. D min. (mm)	Ordering Code	Pitch		Dimensions mm							Grades	
				RH/LH	mm	TPI	Helix	L1	a	F	Y	L2 ref*	L ref	VBX
4.0	3.2	MS429THF55L16R/L	0.5-1.0	48-24	3.5	16	2.90	0.9	0.75	18.4	35.4	●	○	
	4.2	MS439THF55L16R/L	0.5-1.0	48-24			3.90	1.9				●	○	
6.0	6.2	M659THA55L16R/L	0.5-1.5	48-16			5.89	2.9	0.9	18.5	42.2	●	○	

● In stock ○ Available upon request

Threading

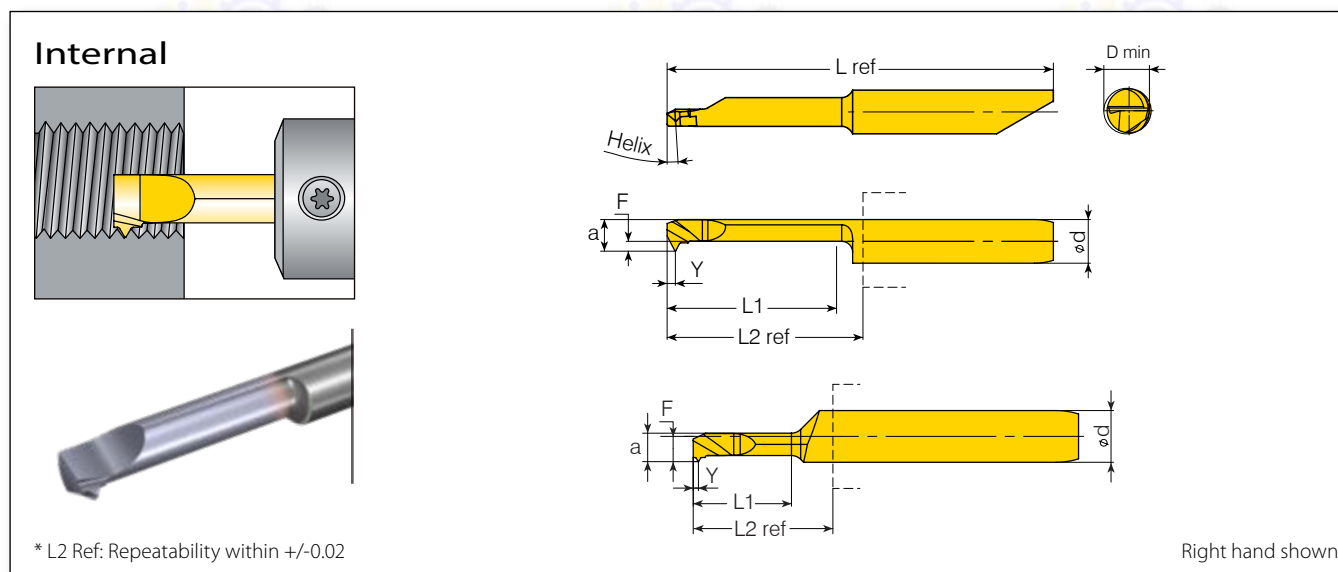

ISO Metric

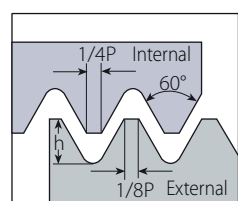

Defined by: R262 (DIN 13)
Tolerance Class: 6g/6H

Thread	Shank Dia. d (mm)	Min. Bore Dia. D min. (mm)	Ordering Code	Pitch mm	Helix °	Dimensions mm							Grades				
						L1	a	F	Y	h (min)	L2 ref*	L ref	VBX	VTX			
M3-M5x0.5	4.0	2.46	M425TH0.50ISOL08R	0.50	3.0	7.6	3.95	1.95	0.40	0.29	13.0	29.8	○	●			
M4x0.7		3.24	M432TH0.70ISOL10R	0.70	3.6	10.2	3.95	1.95	0.60	0.41			○	●			
M4x0.5		3.4	MS429TH0.50ISOL16R/L	0.50	3.5	16	2.90	0.9	0.4	0.29	18.4	35.4	●	○			
M5x0.5		4.4	MS439TH0.50ISOL16R/L	0.50			3.90	1.9	0.4	0.29			●	○			
M4x0.7		3.2	MS429TH0.70ISOL16R/L	0.70			2.90	0.9	0.6	0.41			●	○			
M4.5-M6x0.75		3.1	M429TH0.75ISOL16R	0.75			2.90	1.9	0.6	0.44			○	●			
M5x0.8		4.0	MS429TH0.80ISOL16R/L	0.80			2.90	0.9	0.6	0.46			●	○			
M6x1.0		4.8	MS439TH1.00ISOL16R/L	1.00			3.90	1.9	0.7	0.58			●	○			
M5.5x0.5		5.0	4.9	M542TH0.50ISOL16R/L			0.50	4.20	1.7	0.4			0.29	18.35	41.2	●	○
M5.5x0.75			4.6	M542TH0.75ISOL16R/L			0.75	4.20	1.7	0.6			0.43			●	○
M7x1.0	6.0	5.8	M549TH1.00ISOL16R/L	1.00			4.90	2.4	0.7	0.58			18.5	42.2	●	○	
M6x0.5		5.4	M649TH0.50ISOL16R/L	0.50			4.90	1.9	0.4	0.29					●	○	
M6.5x0.75		5.6	M649TH0.75ISOL16R/L	0.75	4.90	1.9	0.6	0.43	●	○							
M7.5x1.0		6.3	M659TH1.00ISOL16R/L	1.00	5.90	2.9	0.7	0.58	●	○							
M8x1.25		6.5	M659TH1.25ISOL16R/L	1.25	5.90	2.9	0.9	0.72	●	○							
M10x1.5		8.3	M659TH1.50ISOL16R/L	1.50	5.90	2.9	1.0	0.87	●	○							

● In stock ○ Available upon request
I All tools are available in LH upon request.

American UN

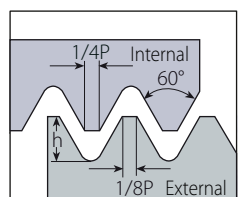

Thread	Shank Dia. d (mm)	Min. Bore Dia. D min. (mm)	Ordering Code	Pitch TPI	Helix °	Dimensions mm							Grades	
						L1	a	F	Y	h (min)	L2 ref*	L ref	VBX	VTX
No.8-32UNC	4.0	3.3	MS429TH32UNL16R/L	32	3.5	16	5.90	0.92	0.6	0.46	18.4	35.4	●	○
No.10-28UNS		3.6	MS429TH28UNL16R/L	28			2.90	0.92	0.65	0.52			●	○
1/4"-27UNS	5.0	5.3	M549TH27UNL16R**	27			4.90	2.4	0.75	0.54	18.35	41.2	●	○
1/4"-24UNS		5.1	M542TH24UNL16R**	24			4.20	1.7	0.75	0.61			●	○
1/4"-20UNC		4.6	M542TH20UNL16R**	20			4.20	1.7	0.9	0.73			●	○
5/16"-18UNC	6.0	6.3	M659TH18UNL16R**	18			5.90	2.9	1.05	0.81	18.5	42.2	●	○
3/8"-16UNC		7.7	M659TH16UNL16R**	16			5.90	2.9	1	0.92			●	○

** LH Tools are available upon request.
● In stock ○ Available upon request



Threading

Internal

* L2 Ref: Repeatability within +/-0.02

Right hand shown

Whitworth for BSW, BSP

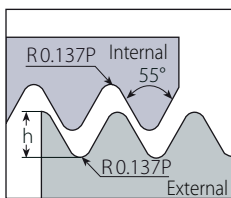

Thread	Shank Dia. d (mm)	Min. Bore Dia. D min. (mm)	Ordering Code	Pitch	Dimensions mm								Grades	
					RH/LH	TPI	Helix °	L1	a	F	Y	h (min)	L2 ref*	L ref
1/16"-28BSP	6.0	6.5	M659TH28WL16R**	28	3.5	16	5.90	2.9	0.65	0.58	18.5	42.2	•	◦
1/4"-19BSP		11.4	M659TH19WL16R**	19					0.95	0.86			•	◦

** LH Tools are available upon request.
 | • In stock ◦ Available upon request

Defined by:

B.S.84:1956, DIN 259, ISO228/1:1982

Tolerance Class:

Medium Class A

NPT

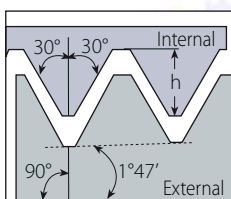

Thread	Shank Dia. d (mm)	Min. Bore Dia. D min. (mm)	Ordering Code	Pitch	Dimensions mm								Grades	
					RH/LH	TPI	Helix °	L1	a	F	Y	h (min)	L2 ref*	L ref
1/16"-27NPT	6.0	6.1	M659TH27NPTL16R**	27	3.5	16	5.90	2.9	0.75	0.66	18.5	42.2	•	◦
1/4"-18NPT		10.7	M659TH18NPTL16R/L	18					1	1.01			•	◦
1/2"-14NPT		17.0	M659TH14NPTL16R**	14					1.05	1.33			•	◦

** LH Tools are available upon request.
 | • In stock ◦ Available upon request

Defined by:

USAS B2.1:1968

Tolerance Class:

Standard NPT

Trapez

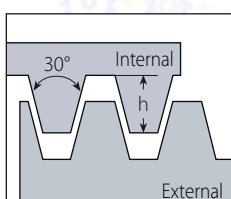

Thread	Shank Dia. d (mm)	Min. Bore Dia. D min. (mm)	Ordering Code	Pitch	Dimensions mm								Grades	
					RH/LH	mm	Helix °	L1	a	F	Y	h (min)	L2 ref*	L ref
TR8-TR10x1.5	6.0	6.2	M662TH1.5TRL20R	1.5	3.3	20.3	5.90	2.95	1.1	0.9	23	46.7	◦	•
TR9-TR12x2.0		6.2	M662TH2.0TRL20R	2.0	4		5.95	2.95	1.3	1.25			◦	•
TR10-TR14x2.0	7.0	7.2	M772TH2.0TRL20R	2.0	3.4		6.95	3.45					1.5	1.75
TR11-TR16x3.0		7.2	M772TH3.0TRL20R	3.0	4.75		6.95	3.45	◦	•				

| • In stock ◦ Available upon request
 | All tools are available in LH upon request.

Defined by: DIN 103

Tolerance class: 7e/7H

ТОВ «СМАРТТЕК ІНЖИНІРИНГ», Т. +380-50-396-90-96, info@smarttec.com.ua, https://www.smarttec.com.ua



microscope Toolholders

V-Cap Holders.....	173
Shrink Toolholders.....	174
Round Toolholders without Shoulder.....	175
Round Double-Sided Tools.....	175
Holder with Round Shank - 4 Flats.....	176
Holder with Round Shank - 2 Flats.....	177
Square Shank Toolholders.....	178
Drop Head Toolholders.....	179

microscope Toolholders - Ordering Code System

Holders

MH	C	R	22	-	4	-	5	-	4F
1	2	3	4		5		6		7

V-CAP Holders

MH	C	S	-	4	-	C3
1	2	3		5		8

1 - Product Line MH - Microscope Round Toolholder MHS - Microscope Square Shank Toolholder MHD - Microscope with Drop Head Toolholder	2 - Coolant C or D - Coolant Thru	3 - Round Tools R - Round Bore S - Shrink by Screw	4 - Shank Size (mm) 10 - 28
5 - Bore Size (mm) 4, 5, 6, 7	6 - Bore Size (mm) for Double Bore 4, 5, 6, 7	7 - 4 Flats 4F - Four Flats None - Two Flats	8 - Polygon Size (V-CAP) C3, C4





ТОВ «СМАРТТЕК ІНЖИНІРІНГ», Т. +380-50-396-90-96, info@smarttec.com.ua, https://www.smarttec.com.ua

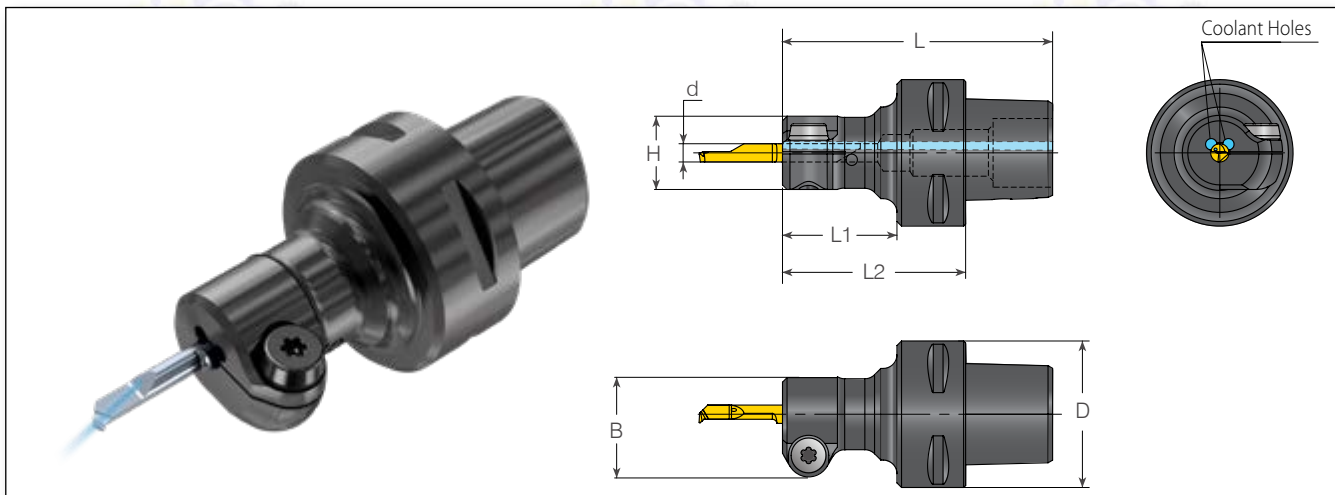

V-CAP Holders



Micro Insert Dia.	Ordering Code	Dimensions mm						Spare Parts	
		D	B	H	L1	L2	L	 Shrink Screw*	 Key
4.0	MHCS-4-C3	32.0	21.7	16.0	25.0	40.0	59.0	SM5X10-15IPX2**	L15IP / LX15IP
	MHCS-4-C4	40.0	21.7	16.0	25.0	45.0	69.0		
5.0	MHCS-5-C3	32.0	23.7	20.0	30.0	45.0	64.0		
	MHCS-5-C4	40.0	23.7	20.0	30.0	50.0	74.0		
6.0	MHCS-6-C3	32.0	23.7	20.0	30.0	45.0	64.0		
	MHCS-6-C4	40.0	23.7	20.0	30.0	50.0	74.0		
7.0	MHCS-7-C3	32.0	23.7	20.0	30.0	45.0	64.0		
	MHCS-7-C4	40.0	23.7	20.0	30.0	50.0	74.0		



V-CAP holders are according to ISO 26623.

* Tightening Torque: 7 Nm max.

** SM5X10-15IPX2 is a special, double-sided screw. For an alternative screw, please use MS5X10 (key: S4).

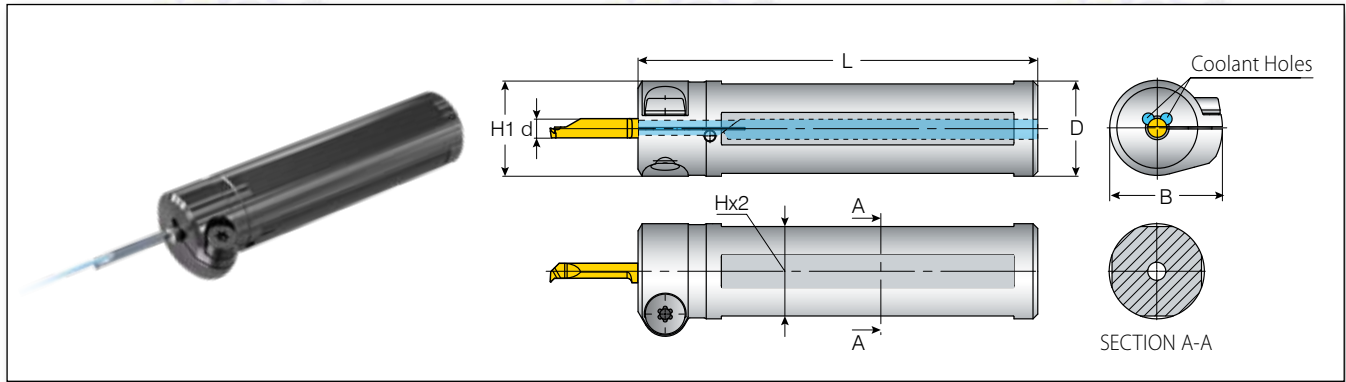
Shrink Toolholders



Micro Insert Dia. d (mm)	Ordering Code	Dimensions mm					Spare Parts	
		D	B	H1	H	L	 Shrink Screw*	 Key
4.0	MHCS10-4-4F	10.0	19.7	13.3	8.8	65.0	SM5X10-15IPX2**	L15IP / LX15IP
	MHCS12-4-4F	12.0	19.7	13.8	10.8	70.0		
	MHCS16-4-4F	16.0	21.7	16.0	14.8	75.0		
	MHCS20-4-4F	20.0	23.7	20.0	18.8	84.0		
	MHCS22-4-4F	22.0	24.7	22.0	20.0	110.0		
5.0	MHCS16-5-4F	16.0	21.7	16.0	14.8	75.0		
	MHCS20-5-4F	20.0	23.7	20.0	18.8	84.0		
	MHCS12-6-4F	12.0	19.7	13.8	10.8	70.0		
6.0	MHCS16-6-4F	16.0	21.7	16.0	14.8	75.0		
	MHCS20-6-4F	20.0	23.7	20.0	18.8	84.0		
	MHCS22-6-4F	22.0	24.7	22.0	20.0	110.0		
7.0	MHCS16-7-4F	16.0	21.7	16.0	14.8	75.0		
	MHCS20-7-4F	20.0	23.7	20.0	18.8	84.0		

* Tightening Torque: 7 Nm max.

** SM5X10-15IPX2 is a special, double-sided screw. For an alternative screw, please use M5X10 (key: S4).

Round Toolholders without Shoulder

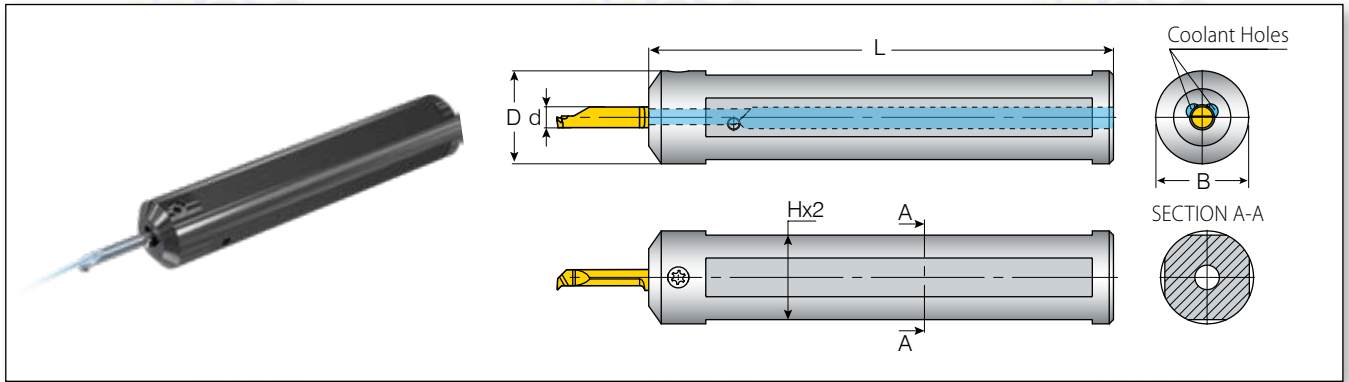

Micro Insert Dia.	Ordering Code	Dimensions mm			Spare Parts	
		B=D	H	L	Clamping Screw*	Key
4.0	MHCR20-4-4F	20	18.8	83.5	SLDBT15IP	F15IP
	MHCR22-4-4F	22	20.0	110.0		
5.0	MHCR20-5-4F	20	18.8	83.5		
	MHCR22-5-4F	22	20.0	110.0		
6.0	MHCR20-6-4F	20	18.8	83.5		
	MHCR22-6-4F	22	20.0	110.0		
7.0	MHCR25-7-4F	25	20.0	110.0		

* Tightening Torque: 7 Nm max.

Round Double-Sided Toolholders

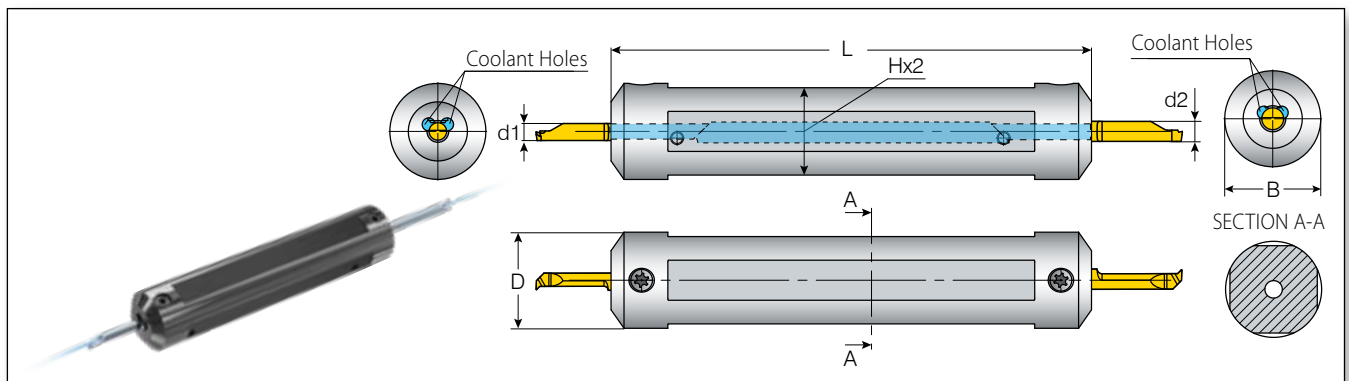



Micro Insert Dia.	Ordering Code	Dimensions mm			Spare Parts	
		B=D	H	L	Clamping Screw*	Key
4.0 - 5.0	MHCR075-4-5-4F**	19.05	17.8	83.5	SLDBT15IP	F15IP
	MHCR20-4-5-4F**	20	18.8	83.5		
	MHCR22-4-5-4F	22	20.0	110.0		
	MHCR25-4-5-4F	25	23.0	110.0		
6.0 - 7.0	MHCR20-6-7-4F**	20	18.8	83.5		
	MHCR25-6-7-4F	25	23.0	110.0		

* Tightening Torque: 7 Nm max.

** Front screw must be removed in order to mount the toolholder on the machine. Once mounted, set the screw back in place and secure the insert.

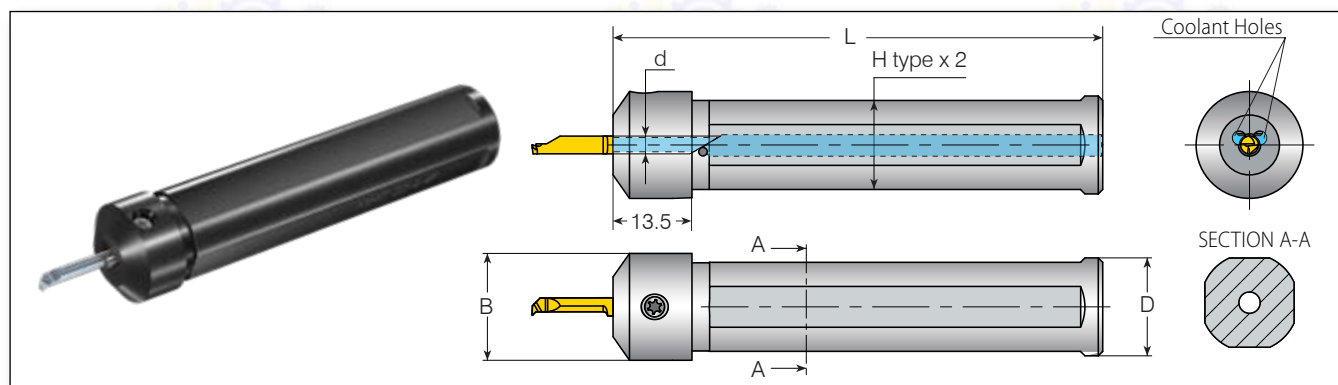
Holder with Round Shank - 4 Flats





						Spare Parts	
Micro Insert Dia.	Ordering Code	Dimensions mm					
d (mm)		D	B	H	L	Clamping Screw*	Key
4.0	MHC20-4-4F	20.0	22.0	18.8	83.5	SL7DT15 or SL7DBT15IP**	KT15 or F15IP**
	MHC22-4-4F	22.0	24.0	20.0	110		
	MHC23-4-4F	23.0	25.0	21.0			
	MHC25-4-4F	25.0	27.0	23.0			
	MHC28-4-4F	28.0	30.0	26.0			
5.0	MHC20-5-4F	20.0	22.0	18.8			
	MHC22-5-4F	22.0	24.0	20.0	110		
	MHC23-5-4F	23.0	25.0	21.0			
	MHC25-5-4F	25.0	27.0	23.0			
	MHC28-5-4F	28.0	30.0	26.0			
6.0	MHC20-6-4F	20.0	22.0	18.8			
	MHC22-6-4F	22.0	24.0	20.0	110		
	MHC23-6-4F	23.0	25.0	21.0			
	MHC25-6-4F	25.0	27.0	23.0			
	MHC28-6-4F	28.0	30.0	26.0			
7.0	MHC22-7-4F	22.0	24.0	20.0		110	
	MHC23-7-4F	23.0	25.0	21.0			
	MHC25-7-4F	25.0	27.0	23.0			
	MHC28-7-4F	28.0	30.0	26.0			

* Tightening Torque: 8 Nm max.

** Torx+ screw and key are now available for improved clamping.

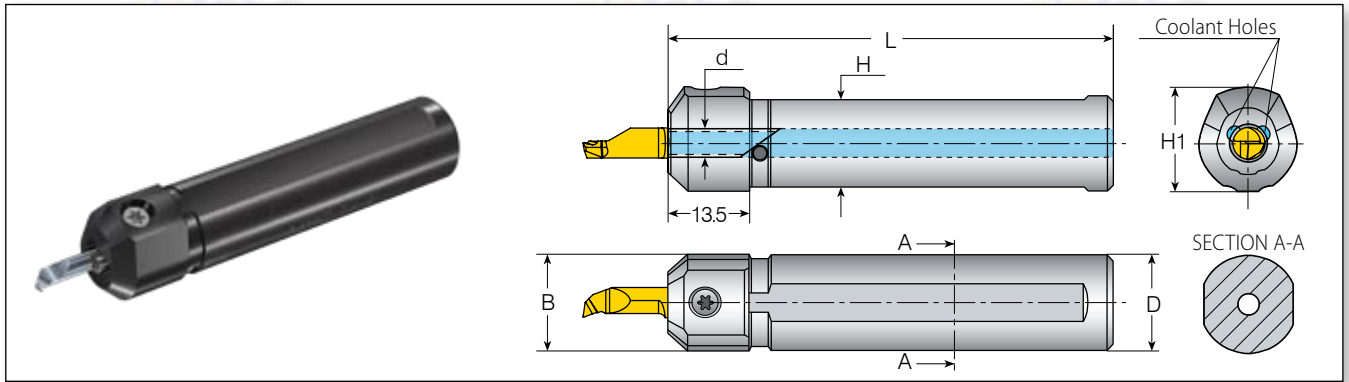
Holder with Round Shank - 2 Flats





Micro Insert Dia.	Ordering Code	Dimensions mm				Spare Parts	
		D=B	H1	H	L	 Clamping Screw*	 Key
4.0	MHC 10-4	10.0	14.0	8.8	65.0	SL7DT15 or SL7DBT15IP**	KT15 or F15IP**
	MHC 12-4	12.0	16.0	10.8	70.0		
	MHC 16-4	16.0	17.6	14.8	75.0		
	MHC 20-4	20.0	22.0	18.8	84.0		
5.0	MHC 10-5	10.0	14.0	8.8	65.0		
	MHC 12-5	12.0	16.0	10.8	70.0		
	MHC 16-5	16.0	18.6	14.8	75.0		
	MHC 20-5	20.0	22.0	18.8	84.0		
6.0	MHC 12-6	12.0	16.0	10.8	70.0		
	MHC 16-6	16.0	18.6	14.8	75.0		
	MHC 20-6	20.0	22.0	18.8	84.0		
7.0	MHC 16-7	16.0	18.6	14.8	75.0		
	MHC 20-7	20.0	22.0	18.8	84.0		

* Tightening Torque: 8 Nm max.

** Torx+ screw and key are now available for improved clamping.

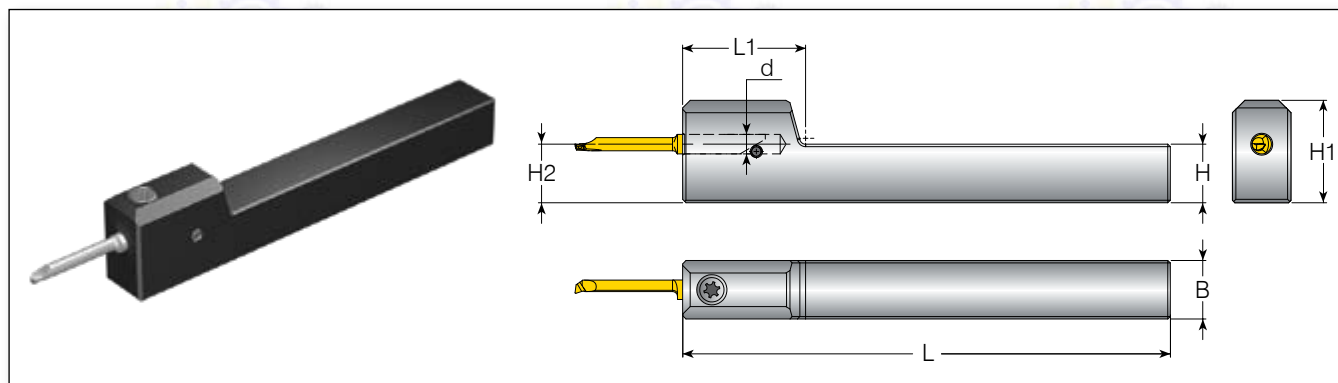
Square Shank Toolholders





Micro Insert Dia.	Ordering Code	Dimensions mm				Spare Parts	
		H=H2=B	H1	L	L1	 Clamping Screw*	 Key
4.0	MHS 1010-4	10.0	19.0	100.0	25.0	SL7DT15 or SL7DBT15IP**	KT15 or F15IP**
5.0	MHS 1010-5	10.0	19.5	100.0	25.0		
4.0	MHS 1212-4	12.0	21.0	100.0	25.0		
5.0	MHS 1212-5	12.0	21.5	100.0	27.0		
6.0	MHS 1212-6	12.0	22.0	100.0	27.0		

* Tightening Torque: 8 Nm max.

** Torx+ screw and key are now available for improved clamping.

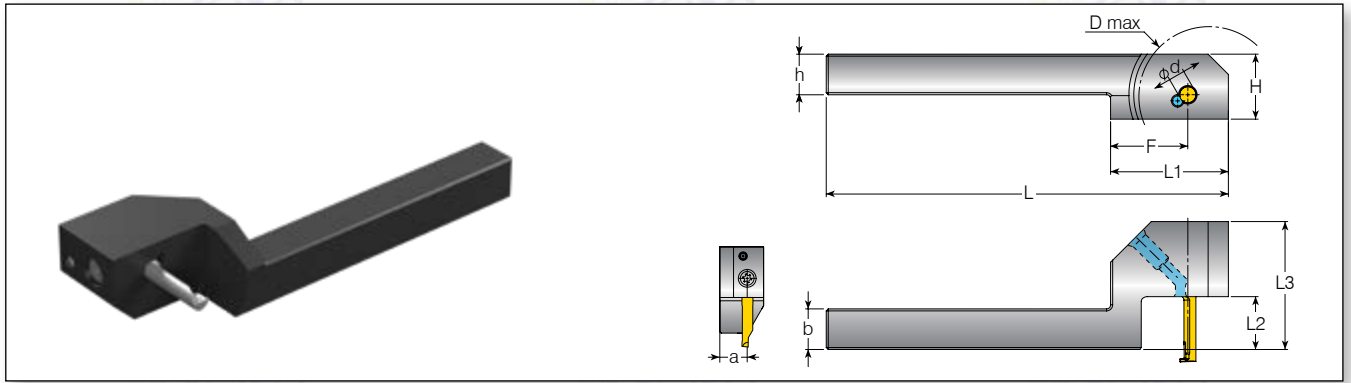
Drop Head Toolholders



Micro Insert Dia.	Ordering Code	Dimensions mm								Spare Parts	
		a=b=h	L3	H	L	L1	F	D max	L2		
4.0	MHD 1010-4 L0500		31.5						13.0	SL7DT15 or SL7DBT15IP**	KT15 or F15IP**
5.0	MHD 1010-5 L0800	10.0	48.0	16.0				23.0			
6.0	MHD 1010-6 L1000		53.0		99.0	29.0	19.0	28.0			
4.0	MHD 1212-4 L0700		36.5					18.0			
5.0	MHD 1212-5 L0800	12.0	48.0	18.0				23.0			
6.0	MHD 1212-6 L1000		53.0					28.0			

* Tightening Torque: 8 Nm max.

** Torx+ screw and key are now available for improved clamping.

Groove Turning Accessories

Torque Limiters for Secure Clamping





Torque Limiting Handles

Ordering Code	Item Number	Range
VTRF 	013-01038	0.6 Nm to 3.0 Nm
VTRJ 	013-01039	2.0 Nm to 7.0 Nm

Torque Limiting Adapters

	Ordering Code	Item Number	Torque Max (Nm)
	TSD-12-0.6Nm	013-01082	0.6
	TSD-12-2.0Nm	013-01083	2.0
	TSD-12-3Nm	013-01037	3.0
	D02-12-3.0Nm	013-01084	3.0
	TSD-12-4.5Nm	013-01044	4.5
	TSD-12-5Nm	013-01045	5.0
	TSD-20-7Nm	013-01046	7.0

Torque Limiting Bits

	Ordering Code	Item Number	Bit Type
	BIT25-H4.0	013-01041	 Hexagon
	BIT25-H5.0	013-01086	
	BIT25-TX8	013-01085	 Torx
	BIT25-TX10	013-01094	
	BIT25-TX15	013-01042	
	BIT25-TX20	013-01043	
	BIT25-TX25	013-01093	 Torx Plus
	BIT25-15IP	013-01036	
BIT25-20IP	013-01040		

Torque Limiters Appendix

Selecting the Correct Adapter and Bit:

Use the following table to choose the correct adapter and bit based on the appropriate Groovex product family and the designated screw.

In cases where different screws are used within the same product family, locate the appropriate screw in the Groovex Main Catalog.

Product Group	Product Family	Insert	Screw	Nm Max	Adapter	Bit	
VG-Cut	Monoblock Holders	Insert Width: 2.0 mm	SM4x16-T20	3.0	TSD-12-3Nm	BIT25-TX20	
		Insert Width: 3.0 mm	SM3.5x14-T15	5.0	TSD-12-5Nm		
		Insert Width: 3.0 mm	SM4x16-T20	5.0	TSD-12-5Nm		
		Insert Width: 3.0 & 4.0 mm	SM4x18-T20	5.0	TSD-12-5Nm		
		Insert Width: 3.0 & 4.0 mm (VGER/L...N & VGER/L...C)	SM5x20-T25	5.0	TSD-12-5Nm	BIT25-TX25	
		Insert Width: 5.0 & 6.0 mm	SM4x18-T20	7.0	TSD-12-7Nm	BIT25-TX20	
	Reinforced Monoblock Holders (PH)	Insert Width: 1.5 & 2.0 mm	SM4x14-T15		3.0	TSD-12-3Nm	BIT25-TX15
		Insert Width: 3.0			5.0	TSD-12-5Nm	
	Reinforced Monoblock Holders with High Pressure Coolant (HPC)	Insert Width: 1.5 & 2.0 mm			4.0	-	BIT25-TX15
		Insert Width: 3.0			5.0	TSD-12-5Nm	
	Modular System		SM4x14-T15	5.0	TSD-12-5Nm	BIT25-TX15	
			SM4X10.5-T15	5.0	TSD-12-5Nm		
			SM5x13.5-T20	5.0	TSD-12-5Nm	BIT25-TX20	
			SM5x18-T20	5.0	TSD-12-5Nm		
	Modular System with High Pressure Coolant	Insert Width: 2.0 mm	SM5x16	3.0	TSD-12-3Nm	BIT25-TX25	
		Insert Width: 3.0 & 4.0 mm	SM5x16	5.0	TSD-12-5Nm		
		Insert Width: 5.0 & 6.0 mm	SM5x16	7.0	TSD-20-7Nm		
	Internal Holders	Insert Width: 2.0 mm	SM5x12	3.0	TSD-12-3Nm	BIT25-TX25	
			SM5x14	3.0			
			SM5x16	3.0			
		Insert Width: 3.0 & 4.0 mm	SM5x12	5.0	TSD-12-5Nm		
SM5x14			5.0	TSD-12-5Nm			
Insert Width: 4.0 & 5.0 mm		SM5x16	5.0	TSD-12-5Nm			
		SM5x18	5.0				
Insert Width: 5.0 mm		SM5x20	5.0				
Insert Width: 6.0 mm	SM5x25	5.0					
ST-Cut		Inserts ST85....	SM5x0.5x7-T10	3.0	D02-12-3.0Nm*	BIT25-TX10	
		SM5x0.8x9-T10					
		SM5x0.5x7-T10 LH					
		SM5x0.8x9-T10 LH					
GrooVical			SGM5	4.5	TSD-12-4.5Nm	BIT25-20IP	
Mini-V			SNV08	0.6	TSD-12-0.6Nm	BIT25-TX8	
			SNV11	2.0	TSD-12-2.0Nm	BIT25-TX10	
			SNV14	3.0	TSD-12-3Nm	BIT25-TX15	
			SNV16	5.0	TSD-12-5Nm	BIT25-TX20	
microscope			SL7DT15	5.0	TSD-12-5Nm	BIT25-TX15	
			SLDBT15IP	5.0	TSD-20-5Nm		
			SM5x10-15IPX2	7.0	TSD-20-7Nm		

* CW/CCW Torque direction



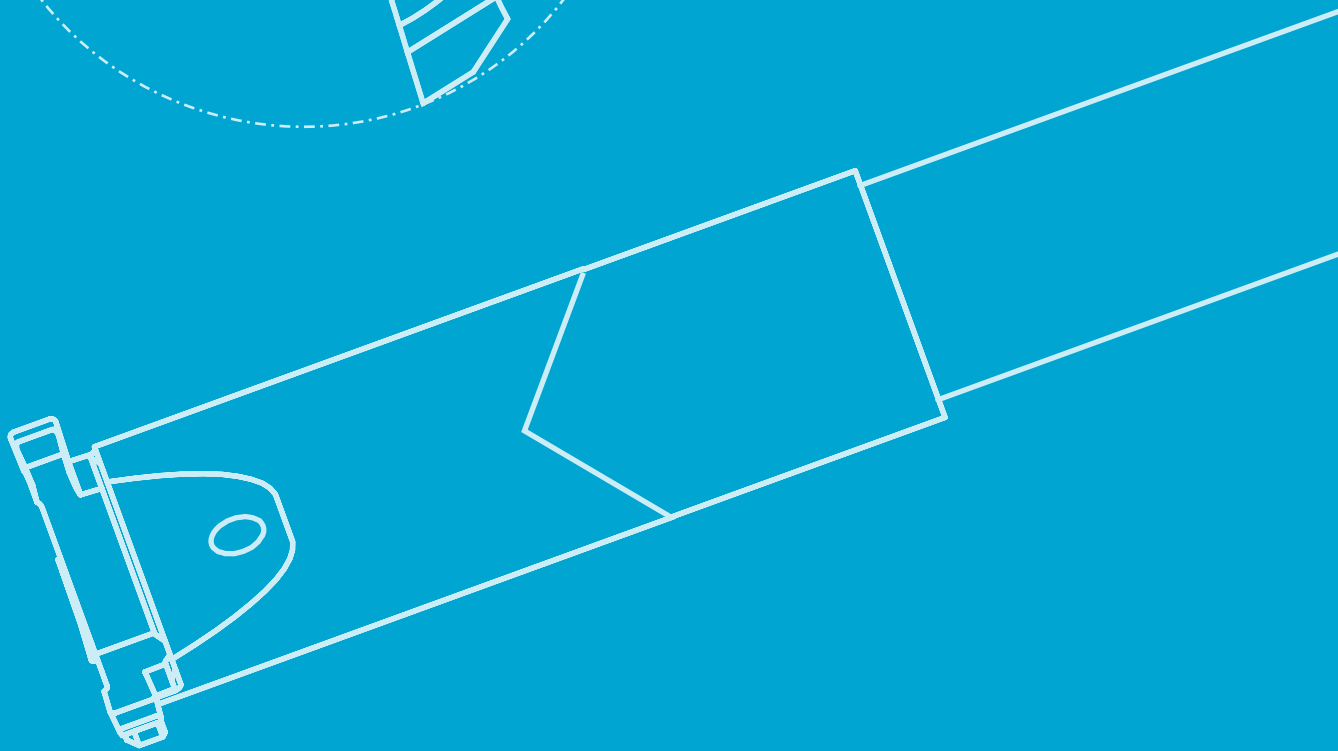
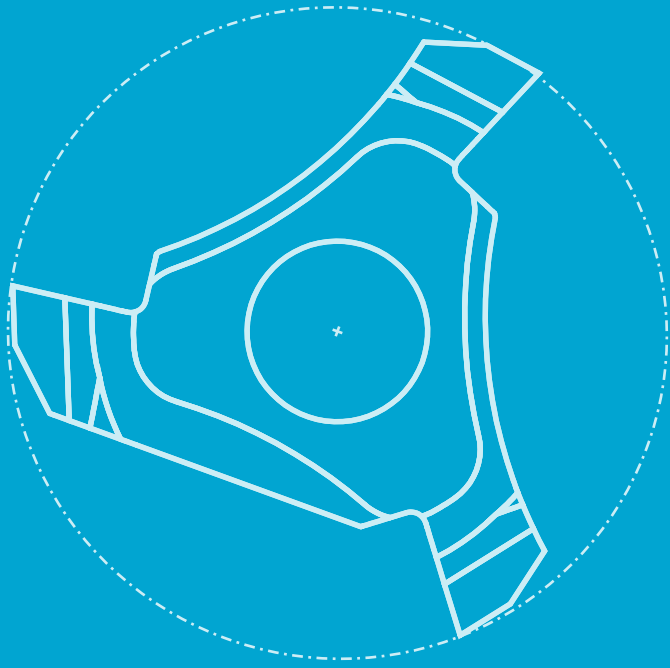

GROOVE MILLING

GM Solid	185
GM Slot	191





GROOVE MILLING

GM Solid

Solid Carbide Groove Milling Tools
for Miniature and Small Bores

GM Solid

Solid Carbide Groove Milling Tools
for Miniature and Small Bores

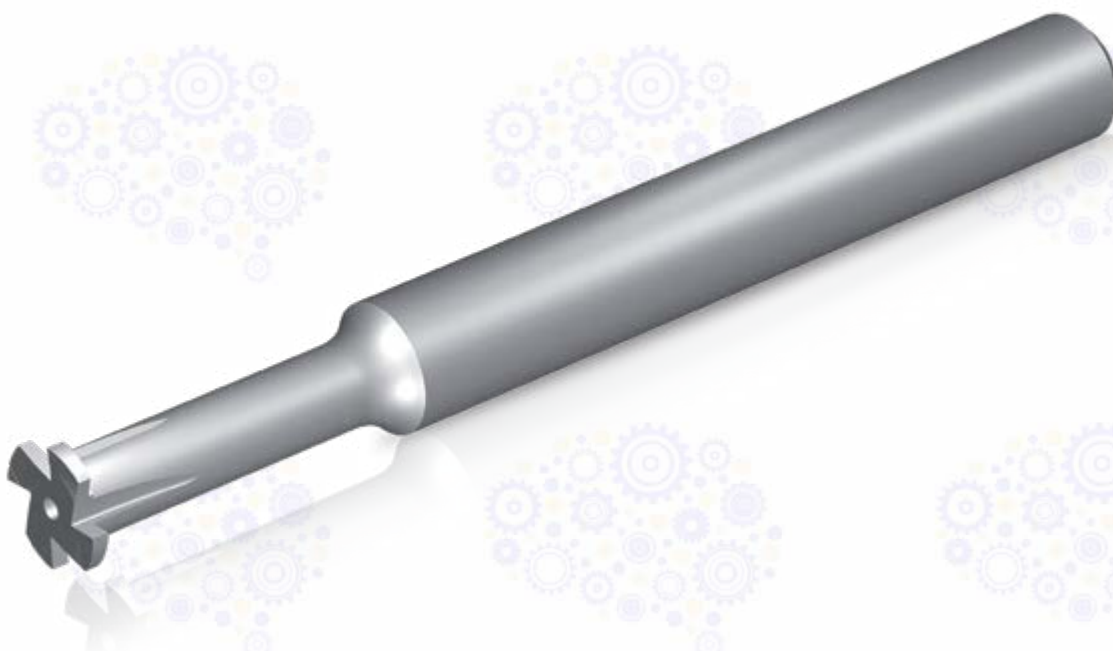

Ø3.0 - 10.00 mm

- Min. bore diameter 6mm
- 4 flutes
- Width of groove 0.7-2.0 mm
- Depth of groove max 1.5mm

GM Solid Groove Milling Technical Data

Recommended Grades, Cutting Speeds Vc [m/min], Feed f [mm/ tooth]

Material Group	Vargus No.	Material	Hardness Brinell HB	Vc [m/min]	Feed f [mm/tooth]	
				VTH	f	
P Steel	1	Unalloyed steel	Low carbon (C=,1-.25 %)	125	100-210	0.07-0.2
	2		Medium carbon (C=.25-.55 %)	150	100-180	0.07-0.2
	3		High Carbon (C=.55-.85 %)	170	100-170	0.07-0.2
	4	Low alloy steel (alloying elements ≤5%)	Non hardened	180	60-90	0.07-0.2
	5		Hardened	275	80-150	0.07-0.2
	6		Hardened	350	70-140	0.07-0.2
	7	High alloy steel (alloying elements >5%)	Annealed	200	60-130	0.07-0.2
	8		Hardened	325	70-110	0.07-0.2
	9	Cast steel	Low alloy (alloying elements <5%)	200	100-170	0.07-0.2
	10		High alloy (alloying elements >5%)	225	70-120	0.07-0.2
M Stainless Steel	11	Stainless steel Ferritic	Non hardened	200	100-170	0.07-0.2
	12		Hardened	330	100-170	0.05-0.15
	13	Stainless steel Austenitic	Austenitic	180	70-140	0.07-0.2
	14		Super Austenitic	200	70-140	0.07-0.2
	15	Stainless steel Cast Ferritic	Non hardened	200	70-140	0.1-0.2
	16		Hardened	330	70-140	0.07-0.2
	17	Stainless steel Cast austenitic	Austenitic	200	70-120	0.07-0.2
	18		Hardened	330	70-120	0.07-0.2
K Cast Iron	28	Malleable Cast iron	Ferritic (short chips)	130	60-130	0.1-0.22
	29		Pearlitic (long chips)	230	60-120	0.07-0.2
	30	Grey cast iron	Low tensile strength	180	60-130	0.07-0.2
	31		High tensile strength	260	60-100	0.07-0.2
	32	Nodular SG iron	Ferritic	160	60-125	0.07-0.2
33	Pearlitic		260	50-90	0.07-0.2	
N(K) Non-Ferrous Metals	34	Aluminum alloys Wrought	non aging	60	100-250	0.1-0.25
	35		Aged	100	100-180	0.1-0.25
	36	Aluminum alloys	Cast	75	150-400	0.1-0.25
	37		Cast & aged	90	150-280	0.1-0.25
	38	Aluminum alloys	Cast Si 13-22%	130	80-150	0.1-0.25
	39	Copper and copper alloys	Brass	90	120-210	0.1-0.25
	40		Bronze and non leaded copper	100	120-210	0.07-0.22
S(M) Heat Resistant Material	23	Titanium alloys	Pure 99.5 Ti	400Rm	70-140	0.07-0.13
	24		α+β alloys	1050Rm	20-50	0.07-0.13

Grades and Their Application

Grade	Application Type	Sample
VTH	A general-purpose, heavy duty groove milling grade TiCN coated for high resistance to wear	

GM Solid Tools

Square Grooving.....	189
Chamfering.....	190

GM Solid Tools - Ordering Code System

Square Grooving

G	S	4	C	070	6	8	L15	R00	VTH
1	2	3	4	5	6	7	8	9	10
1 - Product Line	2 - Type	3 - Number of Flutes		4 - Cooling		5 - Groove Width (inch)			6 - Shank Diameter
G - Grooving	Solid	4 - Four Flutes 6 - Six Flutes		C - Cooling None - Without Cooling		070 - 0.7 mm 080 - 0.8 mm 090 - 0.9 mm 100 - 1.0 mm 150 - 1.5 mm 200 - 2.0 mm			06 - 6 mm 08 - 8 mm 10 - 10 mm
7 - Groove Depth		8 - Overhang Length		9 - Radius					
08 - 0.8 mm 12 - 1.2 mm 15 - 1.5 mm		L15 - 15 mm L25 - 25 mm L35 - 35 mm		R00 - None					
				10 - Carbide Grade					
				VTH					

Chamfering

G	M	4	CH	90	060	06	L15	VTH
1	2	3	4	5	6	7	8	9
1 - Product Line	2 - Type	3 - Number of Flutes		4 - Profile		5 - Angle of Chamfering		6 - Shank Diameter
G - Grooving	Milling	4 - Four Flutes		CH - Chamfering		90		030 - 3 mm 040 - 4 mm 050 - 5 mm 060 - 6 mm 080 - 8 mm
7 - Max. Chamfer Size		8 - Overhang Length		9 - Carbide Grade				
06 - 0.6 mm 12 - 1.2 mm		L15 - 15 mm L25 - 25 mm L35 - 35 mm		VTH				



Square Grooving

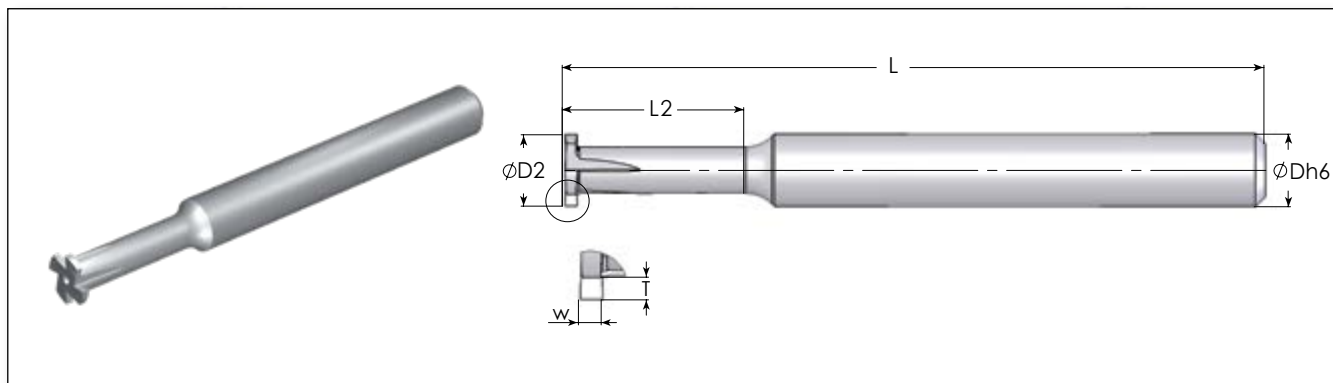

Size	Ordering Code	Dimensions mm						No. of Flutes
		W +/-0.03mm	T max	D2	Dh6	L2	L	
6.0mm	GS4C0700608-L15R00VTH	0.7	0.8	5.9	6.0	15.0	58	4
	GS4C0800608-L15R00VTH	0.8						
	GS4C0900608-L15R00VTH	0.9						
	GS4C1000608-L15R00VTH	1.0						
	GS4C1500608-L15R00VTH	1.5						
8.0mm	GS4C0700812-L25R00VTH	0.7	1.2	7.9	8.0	25.0	68	4
	GS4C0800812-L25R00VTH	0.8						
	GS4C0900812-L25R00VTH	0.9						
	GS4C1000812-L25R00VTH	1.0						
	GS4C1500812-L25R00VTH	1.5						
	GS4C2000812-L25R00VTH	2.0						
10.0mm	GS6C0701015-L35R00VTH	0.7	1.5	9.9	10.0	35.0	78	6
	GS6C0801015-L35R00VTH	0.8						
	GS6C0901015-L35R00VTH	0.9						
	GS6C1001015-L35R00VTH	1.0						
	GS6C1501015-L35R00VTH	1.5						
	GS6C2001015-L35R00VTH	2.0						

ТОВ «СМАРТТЕК ІНЖИНІРИНГ», Т. +380-50-396-90-96, info@smarttec.com.ua, https://www.smarttec.com.ua

Chamfering

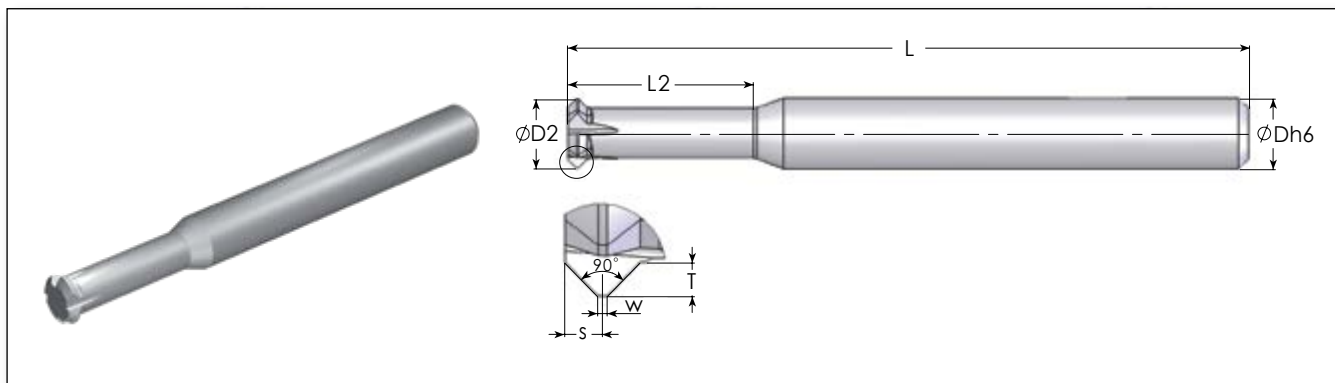

Depth of Cut	Ordering Code							
T max mm		W	D2	Dh6	L2	L	S	No. of Flutes
0.6	GM3CH90 03006-L12 VTH	0.2	2.90	3	12.0	39	0.7	3
0.8	GM3CH90 04008-L10 VTH		3.90	4	10.0	51	0.9	
1.1	GM4CH90 05011-L12 VTH		4.95	5	12.5	51	1.2	
0.6	GM4CH90 06006-L15 VTH		5.90	6	15.0	58	0.8	4
	GM4CH90 06006-L25 VTH				25.0	68		
1.2	GM4CH90 08012-L25 VTH		7.90	8	25.0	68	1.4	
	GM4CH90 08012-L35 VTH			35.0	78			



GROOVE MILLING

GM Slot

Square Grooving, Round Grooving
and Chamfering



GM Slot

Groove Milling Tools with 3 corner indexable inserts for internal and external grooving, threading and chamfering applications

For Small and Medium Bore Diameters

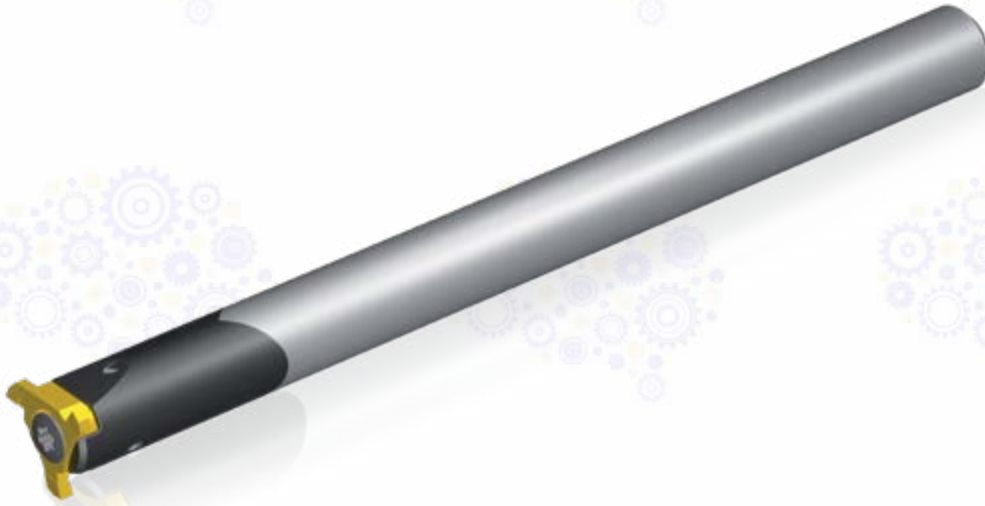

- Min. bore diameter 12.7mm
- 3 flutes
- Width of groove 0.74 - 5.25mm
- Depth of groove max 3.25mm





GM Slot Groove Milling Technical Data

Recommended Grades, Cutting Speeds Vc [m/min], Feed f [mm/tooth]

Material Group	Vargus No.	Material	Hardness Brinell HB	Vc [m/min]	Feed f [mm/tooth]	
P Steel	1	Unalloyed steel	Low carbon (C=.1-.25 %)	125	80-160	0.07-0.3
	2		Medium carbon (C=.25-.55 %)	150	80-150	0.07-0.3
	3		High Carbon (C=.55-.85 %)	170	80-150	0.07-0.3
	4	Low alloy steel (alloying elements ≤5%)	Non hardened	180	80-160	0.07-0.3
	5		Hardened	275	80-150	0.07-0.3
	6		Hardened	350	80-140	0.07-0.25
	7	High alloy steel (alloying elements >5%)	Annealed	200	60-100	0.07-0.3
	8		Hardened	325	50-80	0.07-0.25
	9	Cast steel	Low alloy (alloying elements <5%)	200	80-160	0.07-0.25
	10		High alloy (alloying elements >5%)	225	60-120	0.07-0.25
M Stainless Steel	11	Stainless steel Ferritic	Non hardened	200	70-130	0.07-0.3
	12		Hardened	330	60-110	0.04-0.25
	13	Stainless steel Austenitic	Austenitic	180	70-130	0.07-0.3
	14		Super Austenitic	200	60-120	0.07-0.25
	15	Stainless steel Cast Ferritic	Non hardened	200	80-140	0.07-0.3
	16		Hardened	330	60-100	0.07-0.25
	17	Stainless steel Cast austenitic	Austenitic	200	80-140	0.07-0.3
	18		Hardened	330	60-100	0.07-0.25
K Cast Iron	28	Malleable Cast iron	Ferritic (short chips)	130	50-70	0.07-0.3
	29		Pearlitic (long chips)	230	80-140	0.07-0.25
	30	Grey cast iron	Low tensile strength	180	80-140	0.07-0.3
	31		High tensile strength	260	60-110	0.07-0.25
	32	Nodular SG iron	Ferritic	160	60-100	0.07-0.3
	33		Pearlitic	260	60-100	0.07-0.3
N(K) Non-Ferrous Metals	34	Aluminum alloys Wrought	Non aging	60	80-300	0.07-0.3
	35		Aged	100	100-250	0.07-0.3
	36	Aluminum alloys	Cast	75	100-200	0.07-0.3
	37		Cast & aged	90	100-220	0.07-0.3
	38	Aluminum alloys	Cast Si 13-22%	130	80-300	0.07-0.25
	39	Copper and copper alloys	Brass	90	80-300	0.07-0.3
	40		Bronze and non leaded copper	100	100-200	0.07-0.25
S(M) Heat Resistant Material	23	Titanium alloys	Pure 99.5 Ti	400Rm	40-80	0.07-0.13
	24		α+β alloys	1050Rm	65-164	0.07-0.13

Grades and Their Application

Grade	Application Type	Sample
VBX	TiCN coated carbide grade. Excellent grade for steels and general use.	
VTX	TiAlN coated carbide grade. Ideal for Stainless Steels.	

GM Slot Inserts

Square Grooving.....	195
Round Grooving.....	196
Chamfering.....	197

GM Slot Inserts - Ordering Code System

7	V	GS	1.21	-	1.50	GM	3	VBX
1	2	3	4		5	6	7	8

1 - Insert Size
7 - I.C. 6.8 mm
9 - I.C. 8.5 mm
11 - I.C. 10.7 mm

2 - Insert Style
V - Style

3 - Type of Application
GS - Square Grooving
GSR - Square Grooving with R
GR - Round Grooving
CH - Chamfering

4 - Groove Width
0.74 - 5.15 mm

5 - Groove Depth (mm)
1.50 mm
2.50 mm
3.25 mm

6 - System
GM - Groove Milling

7 - Cutting Edge Number
3

8 - Carbide Grade
VBX
VTX

Square Grooving



Insert Size	Ordering Code	Dimensions mm					Grade		Toolholder	
		RH	W	Width of Circlip	t1	Ds	T	VBX		VTX
7V	7VGS0.74-1.50GM3		0.74	0.70	1.50	12.7	3.15	•	•	CGMC8C13-40-7-3 CCGMC9C13-45-7-3 GMC20W13-25-7-3
	7VGS0.84-1.50GM3		0.84	0.80				•	•	
	7VGS0.94-1.50GM3		0.94	0.90				•	•	
	7VGS1.21-1.50GM3		1.21	1.10				•	•	
	7VGSR1.41-1.50GM3		1.41	1.30				•	•	
	7VGSR1.50-1.50GM3		1.50	-				•	•	
	7VGSR1.57-1.50GM3		1.57	1.50				•	•	
	7VGSR1.71-1.50GM3		1.71	1.60				•	•	
	7VGSR2.00-1.50GM3		2.00	-				•	•	
	7VGSR2.39-1.50GM3		2.39	2.30				•	•	
7VGSR2.50-1.50GM3		2.50	-	•	•					
9V	9VGS1.17-2.50GM3		1.17	1.10	2.50	16.7	4.45	•	•	CGMC7/16C17-45-9-3 CGMC11.5C17-50-9-3 GMC20W17-35-9-3
	9VGS1.41-2.50GM3		1.41	1.30				•	•	
	9VGSR1.50-2.50GM3		1.50	-				•	•	
	9VGSR1.57-2.50GM3		1.57	1.50				•	•	
	9VGSR1.71-2.50GM3		1.71	1.60				•	•	
	9VGSR2.00-2.50GM3		2.00	-				•	•	
	9VGSR2.39-2.50GM3		2.39	2.30				•	•	
	9VGSR2.50-2.50GM3		2.50	-				•	•	
	9VGSR3.00-2.50GM3		3.00	-				•	•	
	9VGSR3.18-2.50GM3		3.18	3.10				•	•	
11V	11VGS1.17-3.25GM3		1.17	1.10	3.25	21.7	5.75	•	•	CGMC14C22-60-11-3 CGMC15C22-65-11-3 GMC25W22-45-11-3
	11VGS1.30-3.25GM3		1.30	-				•	•	
	11VGS1.42-3.25GM3		1.42	1.30				•	•	
	11VGSR1.50-3.25GM3		1.50	-				•	•	
	11VGSR1.55-3.25GM3		1.55	1.45				•	•	
	11VGSR1.57-3.25GM3		1.57	1.50				•	•	
	11VGSR1.71-3.25GM3		1.71	1.60				•	•	
	11VGSR1.85-3.25GM3		1.85	1.75				•	○	
	11VGSR2.00-3.25GM3		2.00	-				•	•	
	11VGSR2.39-3.25GM3		2.39	2.30				•	•	
	11VGSR2.50-3.25GM3		2.50	-				•	•	
	11VGSR3.00-3.25GM3		3.00	-				•	•	
	11VGSR3.18-3.25GM3		3.18	3.10				•	•	
	11VGSR4.00-3.25GM3		4.00	-				•	•	
	11VGSR4.75-3.25GM3		4.75	-				•	•	
11VGSR5.26-3.25GM3		5.26	5.15	•	•					

ТОВ «СМАРТТЕК ІНЖИНІРИНГ», Т. +380-50-396-90-96, info@smarttec.com.ua, https://www.smarttec.com.ua

Round Grooving



Insert Size	Ordering Code		Dimensions mm				Grade		Toolholder
	RH	W	t1	r	Ds	T	VBX	VTX	
7V	7VGR1.10-1.50GM3	2.20	1.50	1.1	12.70	3.15	•	•	CGMC 8C13-40-7-3 CCGMC 9C13-45-7-3 GMC 20W13-25-7-3
9V	9VGR1.10-2.50GM3	2.20	2.50	1.1	16.70	4.45	•	•	CGMC 11.5C17-50-9-3 CGMC 7/16C17-45-9-3 GMC 075W066-118-9-3
11V	11VGR1.00-3.25GM3	2.00		1.0			•	•	CGMC 15C22-65-11-3 CGMC 5/8C22-60-11-3 GMC 100W085-175-11-3
	11VGR1.10-3.25GM3	2.20	3.25	1.1	21.70	5.75	•	•	
	11VGR1.50-3.25GM3	3.00		1.5			•	•	

Chamfering



Insert Size	Ordering Code	Dimensions mm					Grade		Toolholder	
		RH	W	t1	Ds	T	Y	VBX		VTX
7V	7VCH1.20-1.50GM3		1.20	1.50	12.70	3.15	1.60	•	•	CGMC 9C13-45-7-3 CGMC 5/16C13-40-7-3 GMC 075W050-100-7-3"
9V	9VCH1.40-2.50GM3		1.40	2.50	16.70	4.45	2.23	•	•	CGMC 11.5C17-50-9-3 CGMC 7/16C17-45-9-3 GMC 075W066-118-9-3
11V	11VCH1.60-3.25GM3		1.60	3.25	21.70	5.75	2.88	•	•	CGMC 15C22-65-11-3 CGMC 5/8C22-60-11-3 GMC 100W085-175-11-3

ТОВ «СМАРТТЕК ІНЖИНІРИНГ», Т. +380-50-396-90-96, info@smarttec.com.ua, https://www.smarttec.com.ua

GM Slot Toolholders

Carbide Cylindrical Shanks.....	199
Weldon Shanks.....	200

GM Slot Holders - Ordering Code System

Holdings Ordering Code System

C	GM	9	C	13	-	45	-	7	-	3
1	2	3	4	5		6		7		8

1 - Holder Type
C - Carbide Shank
None - Steel Shank

2 - System
GM - Groove Milling

3 - Shank Dia.
8 - 25.4 mm

4 - Shank Style
C - Cylindrical
W - Weldon

5 - Min Cutting Dia.
13 - 13.0mm
17 - 17.0mm
22 - 22.0mm

6 - Tool Overhang
25 - 25.0mm
30 - 30.0mm
40 - 40.0mm
45 - 45.0mm
50 - 50.0mm
60 - 60.0mm
65 - 65.0mm

7 - Insert Size
7 - I.C. 6.8mm
9 - I.C. 8.5mm
11 - I.C. 10.7mm

8 - Number of Flutes
3

Carbide Cylindrical Shanks

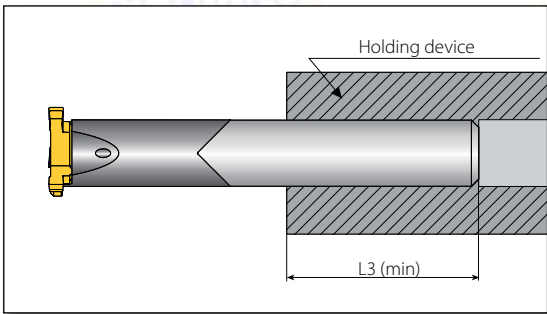
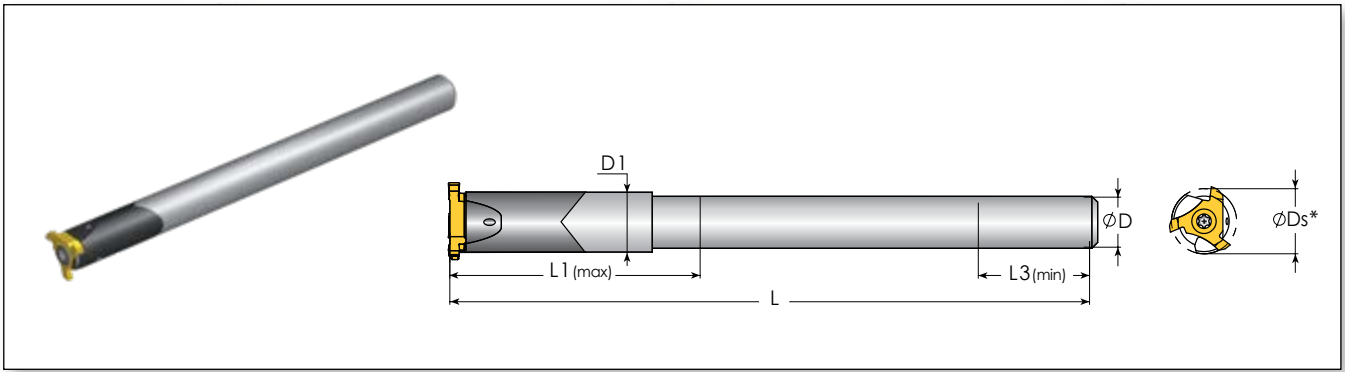

Spare Parts

Insert Size	Ordering Code	Dimensions mm					Spare Parts				
		L	L1	L3 (min)	D	D1	Screw	Size	Key/Blade	Handle	Size
7V	CGMC9C13-45-7-3	115	45	20	9.0	9.0	SN2T8-M1	M3.0x.5x9	K2T	-	Torx T8
	CGMC8C13-40-7-3		40	18	8.0						
	CGMC5/16C13-40-7-3		40	18	8.0						
9V	CGMC11.5C17-50-9-3	125	50	25	11.5	11.5	SN3T15-M2	M4x.7x13.5	Blade T15-1/4	Smart Handle 1/4X2	Torx T15
	CGMC12C17-50-9-3		50	26	12.0						
	CGMC7/16C17-45-9-3		45	25	11.0						
11V	CGMC15C22-65-11-3	135	65	32	15.0	15.0	SN4T20-M3	M5x.8x15.5	Blade T20-1/4	Smart Handle 1/4X2	Torx T20
	CGMC14C22-60-11-3		60	30	14.0						
	CGMC5/8C22-65-11-3		65	34	16.0						

* \varnothing Ds according to insert.

For Correct Clamping:

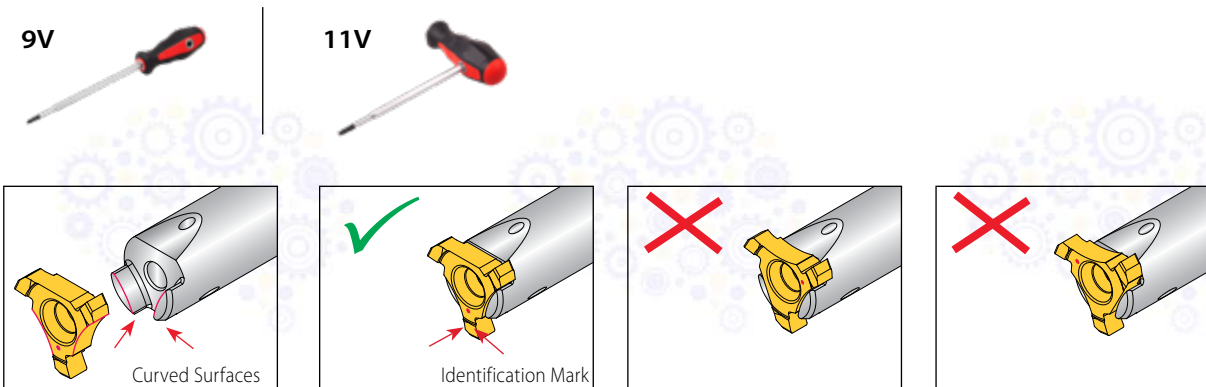

Always mount insert with the identification mark between the two curved surfaces on the toolholder

Weldon Shanks

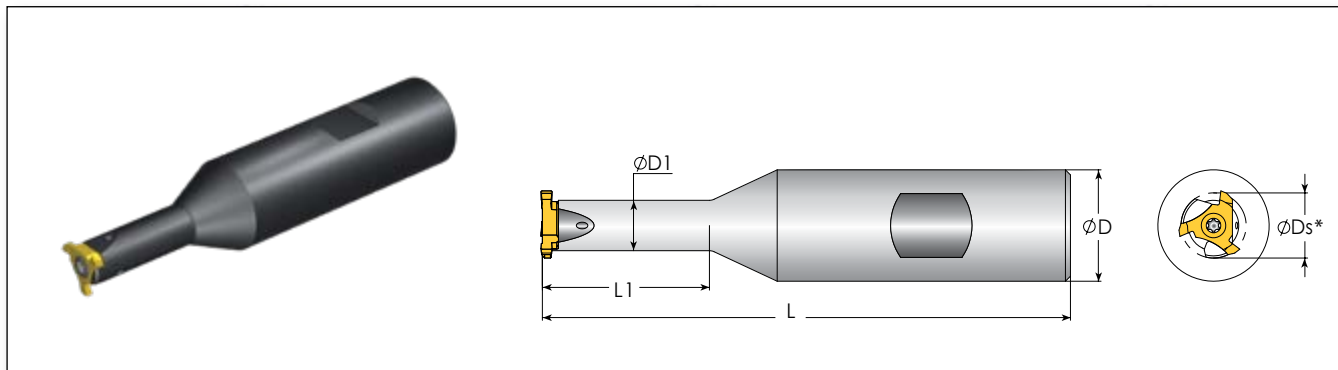

Insert Size	Ordering Code	Dimensions mm				Spare Parts				
		L	L1	D	D1	Screw	Size	Key/Blade	Handle	Size
7V	GMC20W13-25-7-3	95.0	25.0	20.0	9.0	SN2T8-M1	M3.0x0.5x9	K2T	-	Torx T8
	GMC075W050-100-7-3	95.3	25.4	19.0	9.0					
9V	GMC20W17-30-9-3	100.0	30.0	20.0	11.5	SN3T15-M2	M4x0.7x13.5	Blade T15-1/4	Smart Handle 1/4X2	Torx T15
	GMC075W066-118-9-3	101.6	30.0	19.0	11.5					
11V	GMC25W22-45-11-3	115.0	45.0	25.0	15.0	SN4T20-M3	M5x0.8x15.5	Blade T20-1/4	Smart Handle 1/4X2	Torx T20
	GMC100W085-175-11-3	114.3	44.5	25.4	15.0					

* \varnothing Ds according to insert.

For Correct Clamping:

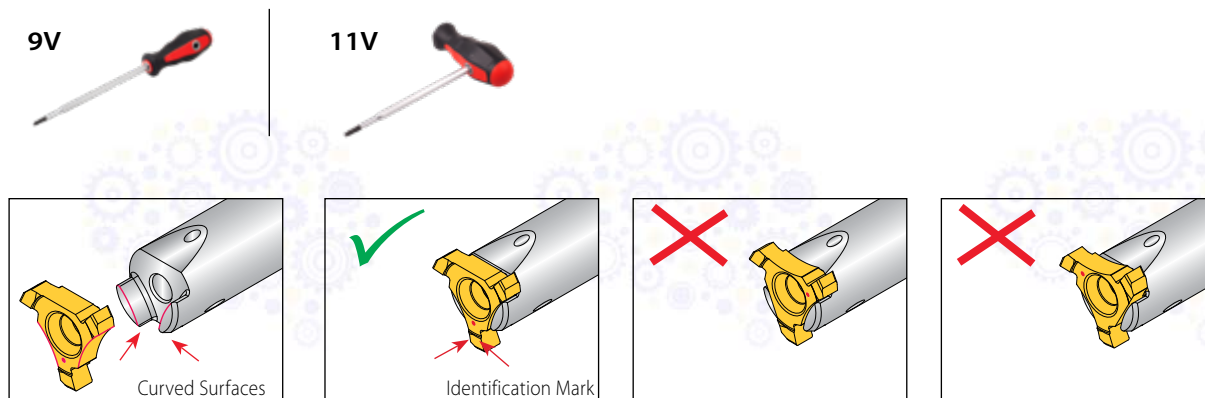

Always mount insert with the identification mark between the two curved surfaces on the toolholder

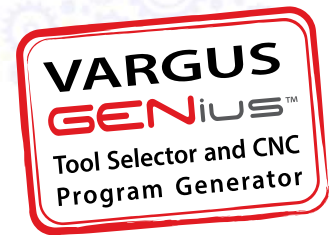
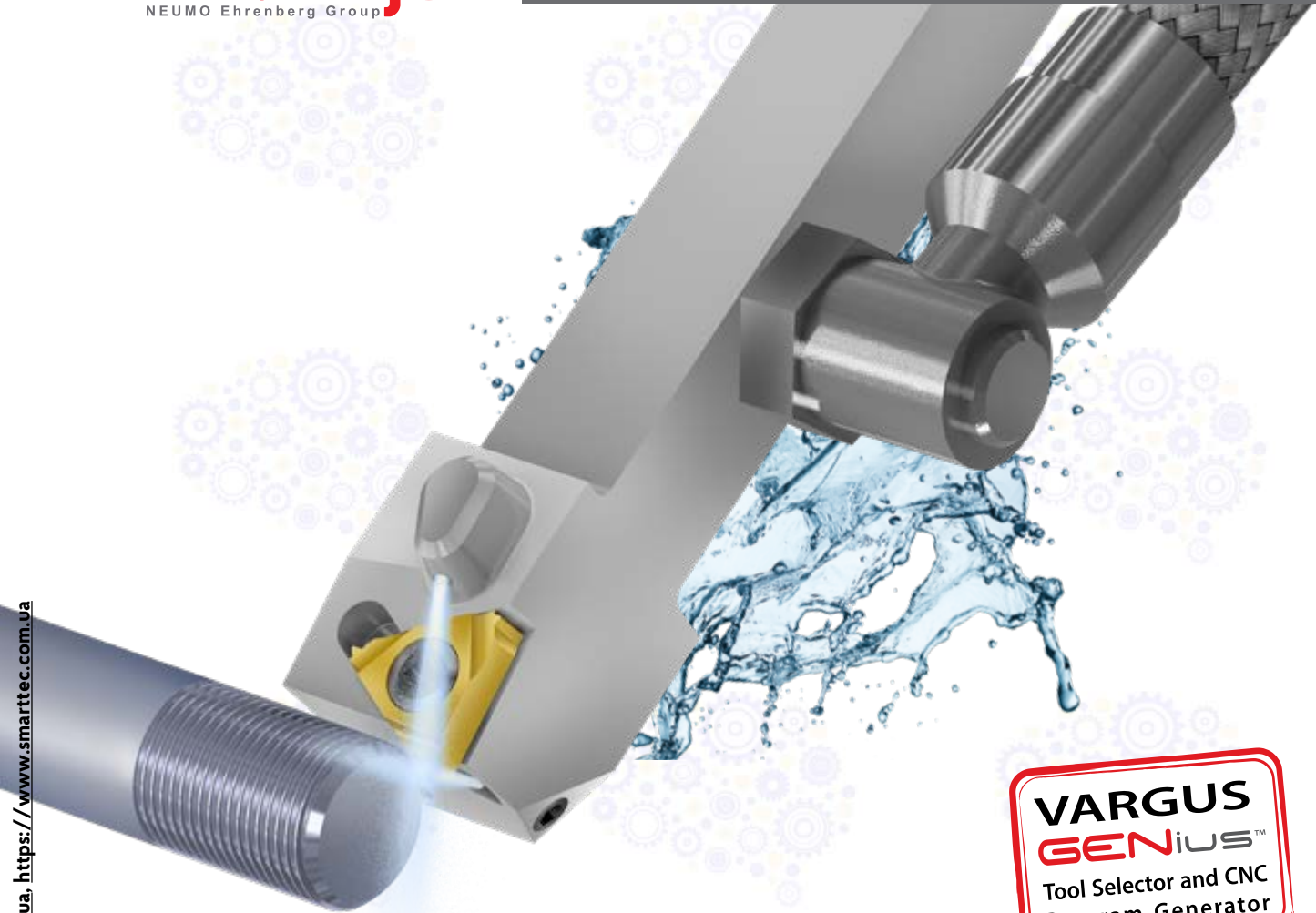

THREADING IS

VARDEX

Advanced Threading Solutions

VARDEX is the company's prominent product line for Thread Turning, Thread Milling, and Gear Milling Solutions.

Thread Turning: The VARDEX TT tools offer an extensive collection of pitches and standards in different grades, IC ranges and types of insert styles, as well as customized solutions for the oil and gas industry.

Thread Milling: The VARDEX TM line provides a wide range of applications and solutions in multi-tooth, single-tooth point for deep holes, and solid carbide tools.

Gear Milling: The VARDEX Gear Milling line is a revolutionary concept for gear, rack and spline applications, offered in indexable inserts and solid carbide tools.

VARGUS GENiUS™: VARGUS' industry-leading Thread Turning and Thread Milling solutions are seamlessly complimented by the VARGUS GENiUS™ software – The most powerful tool selector, cutting data and CNC program generating software available.

ТОВ «СМАРТТЕК ІНЖИНІРИНГ», Т. +380-50-396-90-96, info@smarttec.com.ua, https://www.smarttec.com.ua



VARGUS Medical

Introducing

VARGUS Solutions for the Medical Industry

In keeping with the demands for mass production and special tooling for the medical industry, VARGUS provides an encompassing range of solutions for the precise and detailed applications commonly used world-wide in this rapidly growing industry. Whether it be the manufacturing of miniature dental implants, bone screws, bone plates, tulip heads, or other exact medical components, VARDEX and GROOVEX precision tools provide you with the excellent VARGUS quality so well known in the metal-cutting industry. Tailor-made tools are available on request with the added advantage of the VARGUS expertise and knowledge of more than 60 years.

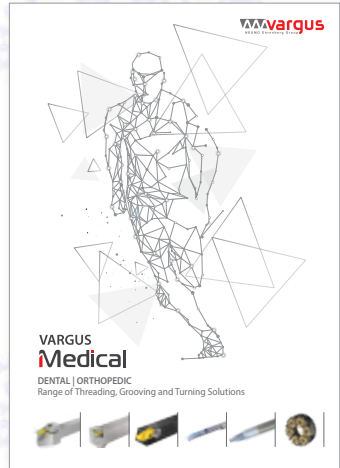

The **Vargus Medical** catalog is now available.

Applications:

- Parting Off
- Turning
- Grooving
- Thread Turning
- Thread Milling
- Thread Whirling
- Boring
- Broaching



V-WHIRLING

Introducing

High Precision Whirling System for Medical and Micromachining Applications



- Ideal solution for long threads on small diameter components
- Close to Spindle Machining
- Indexable inserts with 3 cutting edges and various threading profiles
- Fits popular driven toolholders on Swiss type machines
- VTX Grade - Multipurpose grade for hard to machine materials

The **V-Whirling** catalog is now available.

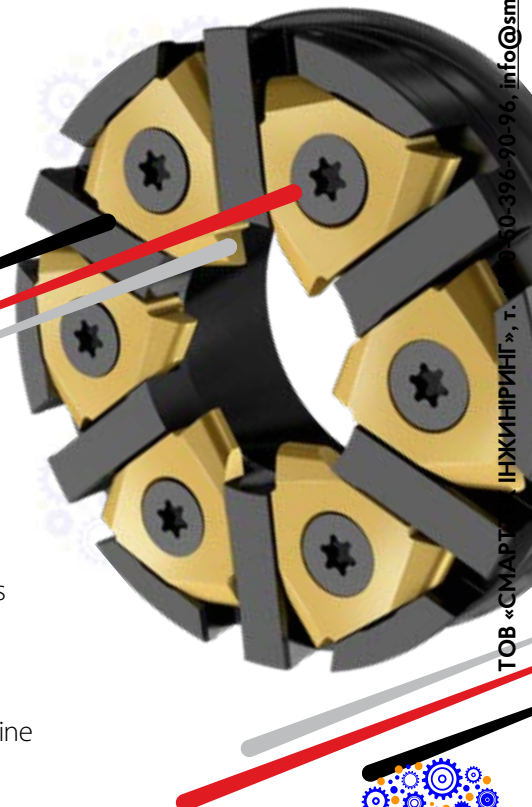

With a network of 13 international companies and hundreds of distributors, warehouses and certified ISO 9001 manufacturing facilities, VARGUS Ltd. serves customers in more than 100 countries around the globe. A customer-focused organization, VARGUS Ltd. is committed to providing innovative products and solutions of the highest quality and excellent value, and is renowned for its technical expertise and uncompromising service.

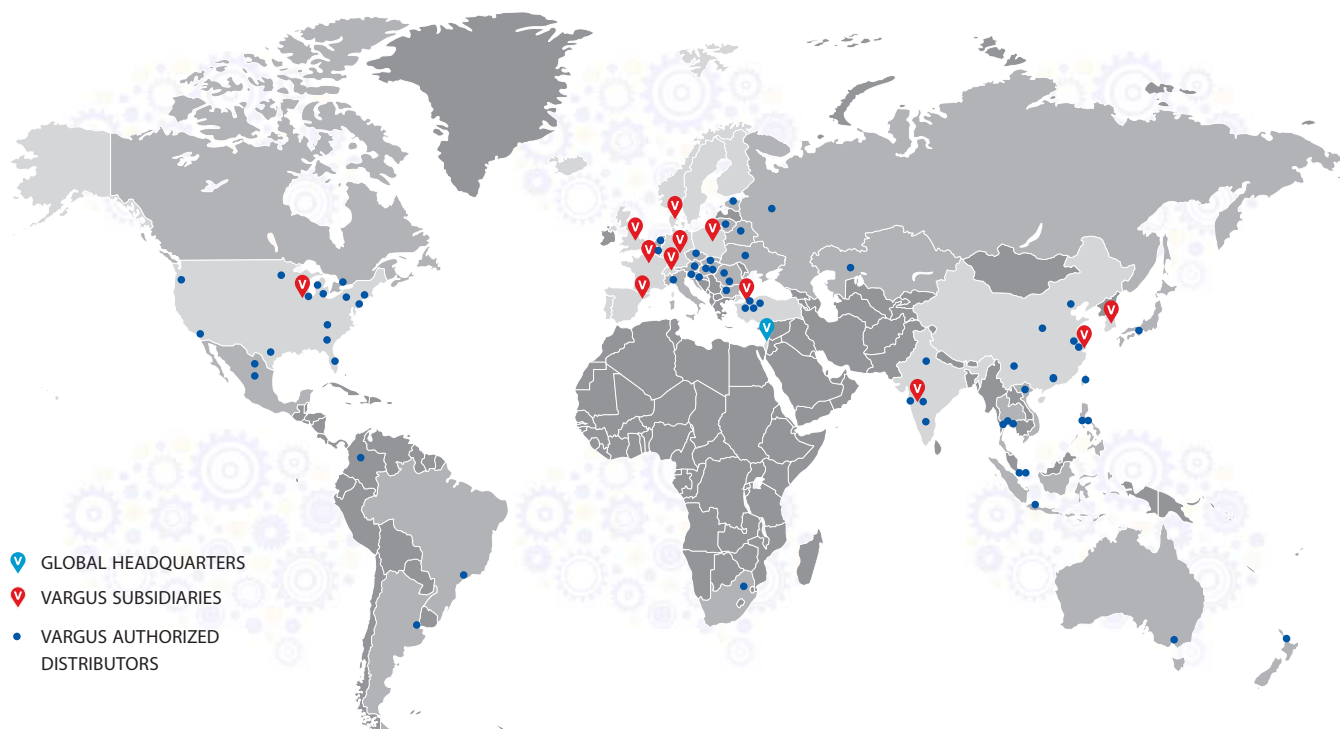

- ▼ GLOBAL HEADQUARTERS
- ▼ VARGUS SUBSIDIARIES
- VARGUS AUTHORIZED DISTRIBUTORS

VARGUS Ltd. - Global Headquarters | ISRAEL +972 4 9855 101 | mrktg@vargus.com

EUROPE

 **DENMARK**
VARGUS Scandinavia
+45 8794 4100
vargus@vargus.dk

 **FRANCE**
VARGUS France
+33 1 4601 7060
commercial@vargus.fr

 **GERMANY**
VARGUS Germany
+49 7043 36 161
info@vargus.de

 **ISRAEL**
NEUMO-VARGUS
+972 3 537 3275
neumo@neumo-vargus.co.il

 **POLAND**
VARGUS Poland
+48 46 834 9904 / 46 831 5140
vargus@neumo.pl

 **SPAIN**
VARGUS Ibérica
+34 977 52 49 00
sales@vargus.es

 **SWITZERLAND**
VARGUS Switzerland
+41 41784 2121
info@vargus.ch

 **TURKEY**
VARGUS Turkey
+90 212 875 01 41
info@vargusturkey.com

 **UNITED KINGDOM**
VARGUS Tooling UK
+44 1952 583 222
tooling.uk@vargustooling.co.uk

ASIA

 **CHINA**
VARGUS China
+86 21 516 88300
info@varguschina.net

 **INDIA**
VARGUS India
+91 2135 654748
info@vargusindia.com

 **SOUTH KOREA**
VARGUS Korea
+82 31 660 7092
info@varguskorea.co.kr

NORTH AMERICA

 **USA**
VARGUS USA
+1 800 828 8765 / 608 756 4930
sales@vargususa.com

ТОВ «СМАРТТЕК ІНЖИНІРИНГ», Т. +380-50-396-90-96, info@smarttec.com.ua, <https://www.smarttec.com.ua>



For the complete list of VARGUS distributors, visit our website at www.vargus.com



GROOVEX
Innovative Grooving & Turning Solutions

MAIN CATALOG | METRIC

